



Global Control Platform (GCP) and 4G Diagnostic Support Manual and
Diagnostic Trouble Code Definitions

Powertrain Assemblies & Components Provided Engine
Distributors Inc.

Part # 1080032
Rev 2

Methods of Obtaining Fault Codes

There are three methods for obtaining fault codes; flashing out via a MIL lamp, using the GCP/4G Display software, reading a CAN enabled display that shows the faults SPN FMI #. All methods are described below.

1. GCP/4G Display Software (EDI part # 5080050): Once connected to the engine go to the faults page. On the bottom of the faults page you can view active and historic faults. Active faults are automatically made historic. By double clicking the red box next to the historic faults, the fault can be cleared and snap shot data can be viewed.

2. Reading the MIL: With a MIL (Malfunction indicator lamp) installed on the unit (Pin 6 of the 42 pin connector, other side of the MIL to 12 volts, this should be installed by the OEM). Then with the key on, engine off, Ground pin 3 of the 42 pin connector. This will start the sequence; each code is flashed three times in a row.

The TSG416, DSG423, and WSG1068 models will first display 1 – 2 – 3 three times. After 1 – 2 – 3 the three or four digit fault codes will be flashed out. If only 1 – 2 – 3 appear; there are no fault codes present. Once all of the faults have been flashed;
1

The TSG415, MSG425, CSG637 and RSG862 models will first display 1 – 6 – 5 – 4 three times. After 1 – 6 – 5 – 4 the three or four digit fault codes will be flashed out. If only 1 – 6 – 5 – 4 appear; there are no fault codes present. Once all of the faults have been flashed; 1 – 6 – 5 – 4 will be flashed again and the sequence will start again.

3. Reading the CAN enabled display. The display will output an SPN and FMI # for each fault code that occurs on the unit. Use the SPN and FMI # to cross it to the ECUs DTC code list.

Diagnostic Tests

The Following tests are available in the 4G Display software.

Test	Description	Page
1	Spark Kill Test	4
2	Spark Fire Test	5
3	DBW Test	6
4	External Power Test	7
5	Compression Test	8
6	Spark Advance Test	9
7	Idle Speed Command	10
8	Fuel / Spark Inhibit Input	11

The 4G engine control module for spark-ignited engine applications incorporates a set of diagnostic tests that perform specific functions to aid in verifying proper engine control. This section describes the tests supported, test states, and operating criteria for each test.

Diagnostic tests are software selectable through EDIS using the ECIPP protocol. In addition, many of the tests can be initiated via CAN using CCP or UDS.

Test Description

Spark Kill

This test disables individual cylinders at any operating condition for the duration defined in calibration (via the 'Spark kill timeout' parameter) or until released through software. Spark Kill may be used in conjunction with Injector Kill to disable up to two cylinders at any given time. Upon a state change from one cylinder to another, the test sequence will automatically re-enable the first coil prior to disabling the selected coil. This test reverts to normal operation if 'Normal' state is selected, ignition voltage is cycled from high to low, or the calibrated timeout expires.



IMPORTANT:

This test should not be initiated prior to the **Injector Kill** test when the engine is equipped with a catalyst. If performed while the injector for the selected cylinder is firing, raw-unburned fuel and air will be present in the exhaust and will react in the catalyst resulting in extremely high catalyst substrate temperatures which can cause wash coat or substrate damage and failure.

States

Available states adjust to accommodate the engine cylinder count configured in the calibration. The Spark kill command dropdown contains one selection for each cylinder as well as a normal operation option ('Normal'). Each cylinder selection includes firing order, block order and pin assignment, as shown below for a common V8 engine configuration:

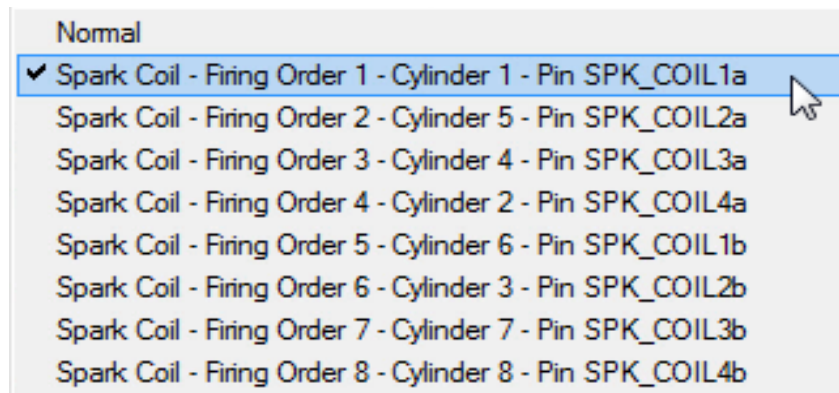

Monitored Status

- 1) Test not started
- 2) Test is running
- 3) Test finished (timeout achieved)
- 4) Cannot start test

Test Description

Spark Fire Test

This test activates a selected coil for a duration defined in the calibration (via the 'Spark firing test duration' parameter) with the engine in the "Stopped" state only. The test reverts to normal operation if the "Normal" state is selected, ignition voltage is cycled from high to low, engine speed is sensed, or the calibrated timeout expires. This test will not run in conjunction with a Compression test or following an **Injector Fire** test.

States

Available states adjust to accommodate the engine cylinder count configured in the calibration. The Spark kill command dropdown contains one selection for each cylinder as well as a normal operation option ('Normal'). Each cylinder selection includes firing order, block order and pin assignment, as shown below for a common V8 engine configuration:

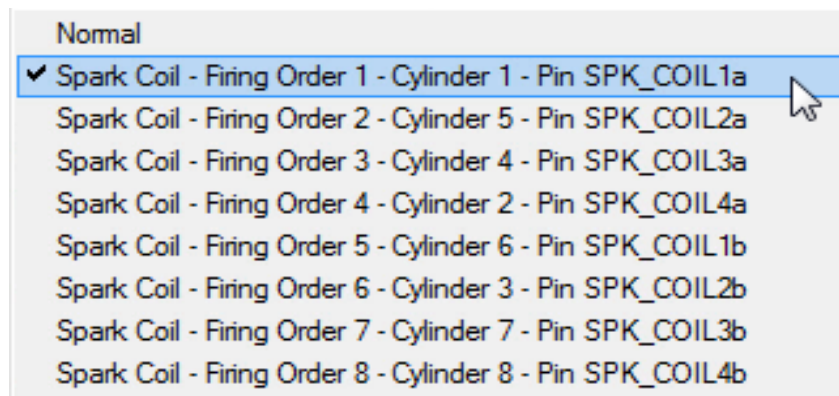

Monitored Status

- 1) Test not started
- 2) Test is running
- 3) Test finished (timeout achieved)
- 4) Cannot start test (speed is sensed)



IMPORTANT:

This test should not be initiated prior to the **Injector Kill** test when the engine is equipped with a catalyst. If performed while the injector for the selected cylinder is firing, raw-unburned fuel and air will be present in the exhaust and will react in the catalyst resulting in extremely high catalyst substrate temperatures which can cause wash coat or substrate damage and failure.

Test Description

DBW Test

The **DBW Test** permits full-authority operation of an electronic throttle via the foot pedal input while the engine is in the 'Stopped' state only. The main purpose of this test is to perform a rationality check on the throttle system and ensure that the connection between the ECM and the throttle is intact, and that commands are being translated to a reasonable throttle position. In order to activate the **DBW Test**, turn on External Power Relays (see **External Power Test** section) to provide the power required by the DBW throttle. Once power relay state is 'All On' then use the foot pedal to command a desired throttle position. The Throttle Position Sensor (TPS) reading should reflect the Foot Pedal Position command (FPP). The feature reverts to normal operation if 'Off' state is selected, key switch is moved to the 'Off' position, or engine speed is sensed.

If the engine is a diesel, ensure that the foot pedal position sensor/electronic throttle control input is at 0% or idle prior to starting/operating the engine. While this test mode will revert to disabled when engine speed is sensed, the throttle command will follow the FPP % commanded by the sensor causing the engine to accelerate.

All other (non-diesel) engines must be stopped in order to perform this test.

States

- 1) Off: State of normal operation
- 2) Enabled: Enables full authority control of an electronic throttle

Monitored Status

- 1) Test not started
- 2) Test is running
- 3) Test finished
- 4) Cannot start test (speed is sensed)

Test Description
External Power Test

The **External Power Test** manually activates relays (relay power, fuel pump, and drive-by wire power) controlled by the ECM while the engine is in the 'Stopped' or 'Running' states. This is required for certain manual test modes in this document, and can be used in the diagnosis of specific component functionality. Reverts to normal operation if 'Automatic' state is selected or ignition voltage is cycled from high to low.

States

- 1) Off: State of normal operation
- 2) Enabled: Enables full authority control of an electronic throttle
- 3) All On: Activates the fuel pump and relay power

Monitored Status

- 1) Test not started
- 2) Test is running
- 3) Test finished
- 4) Cannot start test (no ignition voltage)

Test Description

Compression Test

The **Compression Test** disables all coils and injectors permitting cylinder compression testing. To prevent against firing coils and injectors in the event of a microprocessor reboot during low voltage cranking, the test state will be burned into EEPROM. In addition, EControls requires that the relay power fuse be removed. This test may only be activated while the engine is in the 'Stopped' state. Test reverts to normal operation only when the 'Normal' state is selected. This test may be initiated by selecting 'Enabled' in the software or through use of a switched hardware input. This test may not be run in conjunction with Spark Fire or Injector Fire tests.



IMPORTANT:

Due to the liability of initiating a compression test in software, EControls records this test state into EEPROM. As a result, this test must manually be disabled by the operator through software. EControls recommends this test only be performed while the vehicle is in an appropriate location, in the event the diagnostic PC has a low-battery condition that may not permit re-enabling normal operation.

States

- 1) Disabled: State of normal operation
- 2) Active: Enables compression test mode

Monitored Status

- 1) Test not started
- 2) Test is running
- 3) Test finished
- 4) Cannot start test (engine run speed is sensed > than crank speed)



WARNING:

Due to risk of personal injury and/or property damage, EControls requires any diagnostic/service manuals specify the following:

- 1) Removal of the coil and injector high side relay and/or fuses(s) during a compression test is required.
- 2) Compression test must be enabled only through software controls.

EControls will require a written release of liability against personal injury and property damage from the OEM if diagnostic/service manual procedures do not specify the above requirements.

Test Description

Spark Advance Test

The **Spark Advance Test** commands a calibrated base spark advance if engine speed and manifold pressure are below a calibrated limit. If the engine is operated above the calibrated operating limit, base spark advance as set in the normal calibration will be used until the engine set point falls below the calibrated limit. This test may be initiated by selecting 'Enabled' in the software or through use of a switched hardware input. The test reverts to normal operation when 'Normal' state is selected or when key switch is moved to the 'Off' position.

States

- 1) Disabled: State of normal operation
- 2) Active: Sets spark timing to a calibrated default spark advance

Monitored Status

- 1) Test not started
- 2) Test is running
- 3) Test finished
- 4) Cannot start test

Test Description

Idle Speed Command Test

Idle Speed Command commands a temporary idle speed, up to X RPM as defined in calibration through modulation of an IAC motor or an electronic throttle. Reverts to normal operation when 'Normal' state is selected, a throttle command input (for electronic throttle engines) above Y% (defined in calibration) is detected, a throttle position (for IAC engines) above Z% (defined in calibration) is detected, or key switch is moved to the 'Off' position.

States

- 1) Disabled: State of normal operation
- 2) Active: Enables manual entry of engine speed into a speed entry field

Monitored Status

- 1) Test not started
- 2) Test is running
- 3) Test finished (TPS% above limit is detected during test)
- 4) Cannot start test (TPS% above limit is detected)

Test Description

Idle Speed Command Test

Fuel/Spark Inhibit Input disables triggering of spark and injection of fuel when the input (analog or digital) selected meets the calibrated state. This is often linked to the fuel select switch as a neutral mode.

States

- 1) Disabled
- 2) Aux PU1 = Gnd
- 3) Aux PU2 = Gnd
- 4) Aux PU3 = Gnd
- 5) Aux Dig 1 = Gnd
- 6) Aux Dig 1 = V+
- 7) Aux Dig 2 = Gnd
- 8) Aux Dig 2 = V+
- 9) Aux Dig 3 = Gnd
- 10) Aux Dig 3 = V+
- 11) Aux Dig 4 = Gnd
- 12) Aux Dig 4 = V+
- 13) Aux Dig 1 = Open
- 14) Aux Dig 2 = Open
- 15) Aux Dig 3 = Open
- 16) Aux Dig 4 = Open

Monitored Status

- 1) Test not started
- 2) Test is running

Code			Fault Description	Page
DTC	SPN	FMI		
7	632	3	Lock Off Short to Power	17
11	520800	7	Intake CAM / Distributor Position	18
16	636	8	Never crank synced at start	19
24	520801	7	Exhaust CAM Position	18
31	3222	4	EGO 1 (pre-cat) Heater Circuit Open / Ground Short	243
32	3222	3	EGO 1 (pre-cat) Heater Circuit Short to Power	244
51	3232	4	EGO 2 (post-cat) Heater Circuit Open / Ground Short	243
52	3232	3	EGO 2 (post-cat) Heater Circuit Short to Power	244
87	94	1	Fuel Pressure Low	245
88	94	0	Fuel Pressure High	247
91	94	4	FP low voltage	21
92	94	3	FP high voltage	23
107	106	4	MAP Low Voltage	25
108	106	16	MAP High Pressure	27
111	105	15	IAT higher than expected 1	29
112	105	4	IAT low voltage	31
113	105	3	IAT high voltage	33
116	110	15	ECT higher than expected 1	35
117	110	4	ECT/CHT Low Voltage	37
118	110	3	ECT/CHT High Voltage	39
121	51	1	TPS1 lower than TPS2	41
122	51	4	TPS1 low voltage	43
123	51	3	TPS1 high voltage	45
127	105	0	IAT higher than expected 2	47
129	108	1	BP low pressure	49
134	3217	5	EGO open/lazy pre-cat 1	51
140	3256	5	EGO open/lazy post-cat 1	53
154	3227	5	EGO open/lazy pre-cat 2/post-cat 1	55
160	3266	5	EGO open/lazy post-cat 2	57
171	4237	0	AL high gasoline bank1	59
172	4237	1	AL low gasoline bank1	61
174	4239	0	AL high gasoline bank2	63
175	4239	1	AL low gasoline bank2	65
182	174	4	FT Gasoline Low Voltage	67
183	174	3	FT Gasoline High Voltage	69
187	3468	4	FT Gaseous fuel low voltage	71
188	3468	3	FT Gaseous fuel high voltage	72
217	110	0	ECT higher than expected 2	74
219	515	15	Max govern speed override	76
221	51	0	TPS1 higher than TPS2	77
222	3673	4	TPS2 low voltage	79
223	3673	3	TPS2 high voltage	81
236	102	2	TIP Active	83
237	102	4	TIP Low Voltage	85
238	102	3	TIP High Voltage	87

Code			Fault Description	Page
DTC	SPN	FMI		
261	651	5	Injector Loop Open or Low-side short to Ground	89
262	651	3	Injector Coil Shorted	92
264	652	5	Injector Loop Open or Low-side short to Ground	89
265	652	3	Injector Coil Shorted	92
267	653	5	Injector Loop Open or Low-side short to Ground	89
268	653	3	Injector Coil Shorted	92
270	654	5	Injector Loop Open or Low-side short to Ground	89
271	654	3	Injector Coil Shorted	92
273	655	5	Injector Loop Open or Low-side short to Ground	89
274	655	3	Injector Coil Shorted	92
276	656	5	Injector Loop Open or Low-side short to Ground	89
277	656	3	Injector Coil Shorted	92
279	657	5	Injector Loop Open or Low-side short to Ground	89
280	657	3	Injector Coil Shorted	92
282	658	5	Injector Loop Open or Low-side short to Ground	89
283	658	3	Injector Coil Shorted	92
285	659	5	Injector Loop Open or Low-side short to Ground	89
286	659	6	Injector Coil Shorted	92
288	660	5	Injector Loop Open or Low-side short to Ground	89
289	660	6	Injector Coil Shorted	92
326	731	2	Knock 1 Excessive Signal	95
327	731	4	Knock 1 sensor Open	97
331	520197	2	Knock 2 Excessive Signal	95
332	520197	4	Knock 2 sensor Open	97
336	636	2	Crank sync noise	99
337	636	4	Crank loss	101
341	723	2	Cam sync noise	103
342	723	4	Cam loss	105
359	632	31	Fuel-Run Out Longer Than Expected	107
420	3050	11	Gasoline cat monitor	108
524	100	1	Oil pressure low	111
562	168	17	Battery Voltage Low	113
563	168	15	Battery Voltage High	115
601	628	13	Flash checksum invalid	117
604	630	12	RAM failure	118
606	629	31	COP failure	119
615	1321	5	Start relay coil open	121
616	1321	4	Start relay control ground short	123
617	1321	3	Start relay coil short to power	125
627	1348	5	Fpump relay coil open	127
628	1348	4	Fpump relay control ground short	129
629	1348	3	Fpump relay coil short to power	131
642	1079	4	5VE1 low voltage	133

Code			Fault Description	Page
DTC	SPN	FMI		
643	1079	3	5VE1 high voltage	134
650	1213	5	MIL open	136
685	1485	5	Power Relay Coil Open	138
686	1485	4	Relay Control ground short	140
687	1485	3	Relay coil short to power	142
1068	3563	15	MAP Higher than Expected	144
1111	515	16	Fuel rev limit	145
1112	515	0	Spark rev limit	146
1121	91	31	FPP1/2 simultaneous voltages out of range	147
1122	520199	11	FPP1/2 do not match each other or the IVS	148
1151	4236	0	CL high LPG	149
1152	4236	1	CL low LPG	151
1153	4236	0	CL high NG	149
1154	4236	1	CL low NG	151
1155	4236	0	CL high gasoline bank1	149
1156	4236	1	CL low gasoline bank1	151
1157	4238	0	CL high gasoline bank2	149
1158	4238	1	CL low gasoline bank2	151
1161	4237	0	AL high LPG	153
1162	4237	1	AL low LPG	155
1163	4237	0	AL high NG	153
1164	4237	1	AL low NG	155
1165	3050	11	LPG cat monitor	157
1166	3050	11	NG cat monitor	157
1171	520260	0	Megajector delivery pressure higher than expected	160
1172	520260	1	Megajector delivery pressure lower than expected	162
1173	520260	31	Megajector comm lost	164
1174	520260	3	Megajector voltage supply high	167
1175	520260	4	Megajector voltage supply low	168
1176	520260	12	Megajector internal actuator fault detection	169
1177	520260	12	Megajector internal circuitry fault detection	170
1178	520260	12	Megajector internal comm fault detection	171
1325	731	15	Knock Retard at Limit	172
1351	1268	11	Spark Plug or Coil Failure 1	173
1352	1269	11	Spark Plug or Coil Failure 2	173
1353	1270	11	Spark Plug or Coil Failure 3	173
1354	1271	11	Spark Plug or Coil Failure 4	173
1355	1272	11	Spark Plug or Coil Failure 5	173
1356	1273	11	Spark Plug or Coil Failure 6	173
1357	1274	11	Spark Plug or Coil Failure 7	173
1358	1275	11	Spark Plug or Coil Failure 8	173
1512	701	4	AUX analog PU1 low	175

Code			Fault Description	Page
DTC	SPN	FMI		
1521	110	16	CHT higher than expected 1	177
1522	110	0	CHT higher than expected 2	179
1561	711	3	AUX analog PD2 high	181
1612	629	31	RTI 1 loss	183
1613	629	31	RTI 2 loss	183
1614	629	31	RTI 3 loss	183
1615	629	31	A/D loss	185
1616	629	31	Invalid interrupt	186
1628	639	13	CAN addresss conflict failure	189
1625	1110	31	J1939 Shutdown Request	188
1629	695	9	J1939 TSC1 message receipt lost	191
1631	697	5	PWM1-Gauge1 open / ground short	192
1632	697	3	PWM1-Gauge1 short to power	194
1633	698	5	PWM2-Gauge2 open /ground short	192
1634	698	3	PWM2-Gauge2 short to power	194
1635	699	5	PWM3-Gauge3 open / ground short	192
1636	699	3	PWM3-Gauge3 short to power	194
1641	920	4	Buzzer control ground short	196
1642	920	5	Buzzer open	198
1643	920	3	Buzzer control short to power	200
1644	1213	4	MIL control ground short	202
1645	1213	3	MIL control short to power	204
2111	51	7	Unable to reach lower TPS	206
2112	51	7	Unable to reach higher TPS	208
2115	91	0	FPP1 higher than IVS limit	209
2116	29	0	FPP2 higher than IVS limit	211
2120	520199	11	FPP1 invalid voltage and FPP2 disagrees with IVS	213
2121	91	18	FPP1 lower than FPP2	215
2122	91	4	FPP1 Low Voltage	217
2123	91	3	FPP1 High Voltage	219
2125	520199	11	FPP2 invalid voltage and FPP1 disagrees with IVS	221
2126	91	16	FPP1 higher than FPP2	223
2127	29	4	FPP2 low voltage	217
2128	29	3	FPP2 high voltage	219
2130	558	5	IVS stuck at-idle, FPP1/2 match	225
2131	558	6	IVS stuck off-idle, FPP1/2 match	227
2135	51	31	TPS1/2 simultaneous voltages out of range	229
2139	91	1	FPP1 lower than IVS limit	231
2140	29	1	FPP2 lower than IVS limit	231
2229	108	0	BP high pressure	234
2300	1268	5	Primary Loop Open or Low-side Short to Ground	235

Code			Fault Description	Page
DTC	SPN	FMI		
2301	1268	6	Primary Coil Shorted	237
2303	1269	5	Primary Loop Open or Low-side Short to Ground	235
2304	1269	6	Primary Coil Shorted	237
2306	1270	5	Primary Loop Open or Low-side Short to Ground	235
2307	1270	6	Primary Coil Shorted	237
2309	1271	5	Primary Loop Open or Low-side Short to Ground	235
2310	1271	6	Primary Coil Shorted	237
2315	1273	5	Primary Loop Open or Low-side Short to Ground	235
2316	1273	6	Primary Coil Shorted	237
2318	1274	5	Primary Loop Open or Low-side Short to Ground	235
2319	1274	6	Primary Coil Shorted	237
2321	1275	5	Primary Loop Open or Low-side Short to Ground	235
2322	1275	6	Primary Coil Shorted	237
2618	645	4	Tach output ground short	239
2619	645	3	Tach output short to power	241

Code			Fault Description
DTC	SPN	FMI	
7	632	3	Lock Off Short to Power

The lock off valve connector supplied in the engine harness has two connections. 12 Volt supply power with the keyswitch on, supplied by the VSW, Red/Lt Green Wire. The other connection is the white/black wire which is the ground from the ECU, pin 77.

This fault indicates that the ground, white/black wire has shorted to a voltage source.

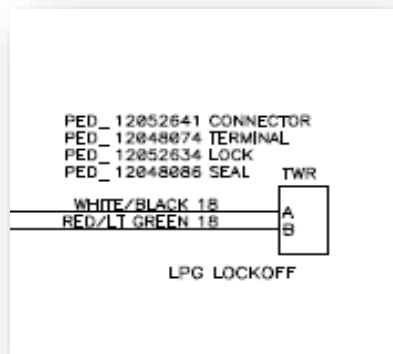

Code			Fault Description
DTC	SPN	FMI	
11	520800	7	Intake CAM / Distributor Position
24	520801	7	Exhaust CAM Position

DTC 11 – Intake cam/distributor position (BANK 1)

On the MSG425 and WSG873 the variable valve timing solenoid is controlled by a PWM (Aux PWM 4, Pin 86 of the GCP) signal from the GCP. The other is a 12 volt supply from the power relay.

When one of these connections is broken, faulty ECU, or faulty solenoid, the solenoid cannot achieve its controlled position and this fault will occur.

- Check wiring to ensure no broken connections
- Verify 12 volts on the red wire
- If wiring is ok, test with known working GCP
- If all of the above is ok, replace the solenoid and retest

DTC 24 – Exhaust cam position (Intake cam BANK 2)

In EDI applications, DTC 24 corresponds to the BANK 2 intake camshaft position and troubleshooting logic of DTC 11 above applies.

LSG635, CSG637, and RSG862 utilize two CAM phasers: Bank 1 PWM is Aux PWM 4, Pin 86, Bank 2 PWM is Aux PWM 5 Pin 84

Code			Fault Description
DTC	SPN	FMI	
16	636	8	Never crank synced at start

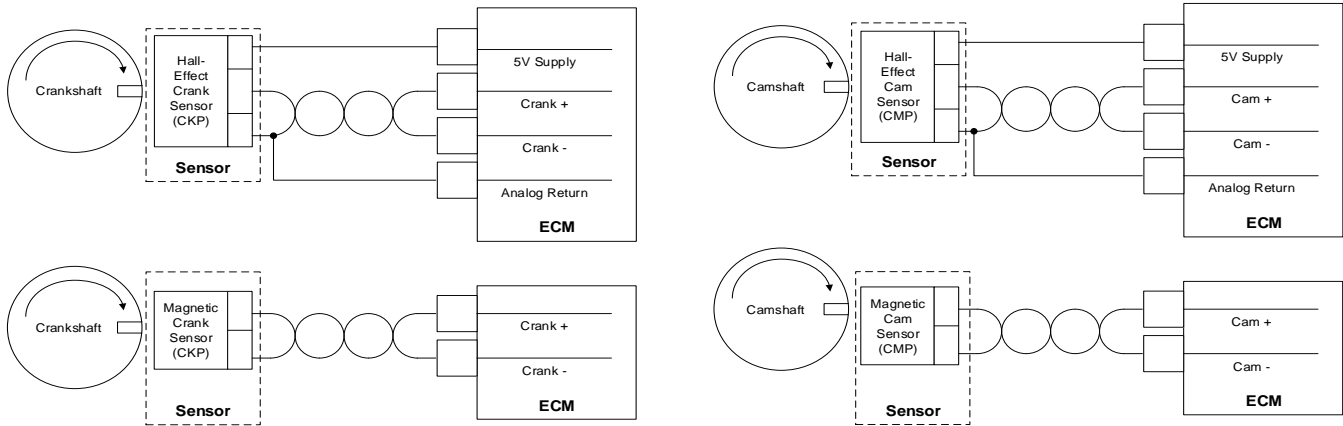

Hardware/Circuit:	Crankshaft Position Sensor/Camshaft Position Sensor
--------------------------	---

Hardware/Circuit Description:	<p>The crankshaft position sensor is a magnetic sensor (variable reluctant/magnetic pick-up or hall-effect) installed in the engine block adjacent to a “coded” trigger wheel located on the crankshaft. The sensor-trigger wheel combination is used to determine crankshaft position (with respect to TDC cylinder #1 compression) and the rotational engine speed. Determination of the crankshaft position and speed is necessary to properly activate the ignition, fuel injection, and throttle governing systems for precise engine control.</p> <p>The camshaft position sensor is a magnetic sensor (variable reluctant/magnetic pick-up or hall-effect) installed in the engine block or valve train adjacent to a “coded” trigger wheel located on or off of the camshaft. The sensor-trigger wheel combination is used to determine cam position (with respect to TDC cylinder #1 compression). Determination of the camshaft position is necessary to identify the stroke (or cycle) of the engine to properly activate the fuel injection system and ignition (for coil-on-plug engines) for precise engine control.</p>
--------------------------------------	--

Possible Causes:	<p>The ECM must see a valid crankshaft position and camshaft position (if applicable) signal properly aligned during cranking before it can synchronize the injection and ignition systems to initiate starting. If engine speed > x RPM and the crank and/or cam (if applicable) cannot synchronize within y cranking revs (NOTE: x and y defined in application-specific calibration), this fault will set.</p> <p>Typically, conditions triggering this fault will result in an engine that will not start or run.</p>
-------------------------	--

<p><i>Diagnostic Aids</i></p> <ul style="list-style-type: none"><input type="checkbox"/> Check that crankshaft and/or camshaft position sensor(s) is/are securely connected to harness.<input type="checkbox"/> Check that crankshaft and/or camshaft position sensor(s) is/are securely installed into engine block.<input type="checkbox"/> Check crankshaft and/or camshaft position sensor(s) circuit(s) wiring for open circuit.	
--	--

Code			Fault Description
DTC	SPN	FMI	
91	94	4	FP low voltage

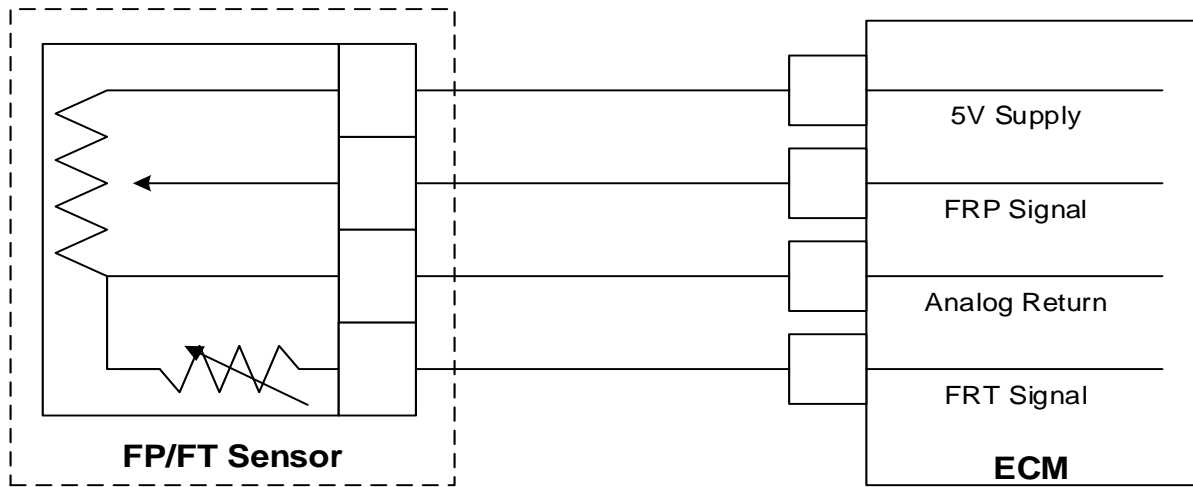

Hardware/Circuit:	Liquid Fuel Pressure and Temperature Sensor
--------------------------	---

Hardware/Circuit Description:	The fuel pressure sensor is installed inline in the gasoline fuel supply line and is used to provide fuel pressure feedback to the ECM. The ECM sets a target rail pressure based on running conditions and then the fuel pump is PWM controlled through a low side driver in the ECM. The fuel pressure sensor feedback is used to determine when the actual rail pressure has reached the target rail pressure.
--------------------------------------	---

Possible Causes:	This fault will set when the FP sensor voltage feedback is sensed as lower than the sensor should normally produce as set in the diagnostic calibration. The limit is generally set at 0.10 VDC. In many cases, this condition is caused by the FP sensor being disconnected from the engine harness, an open-circuit or short-to-ground of the FP circuit in the wire harness, a loss of sensor reference voltage, or a failure of the sensor.
-------------------------	---

DTC 91: Troubleshooting Tree

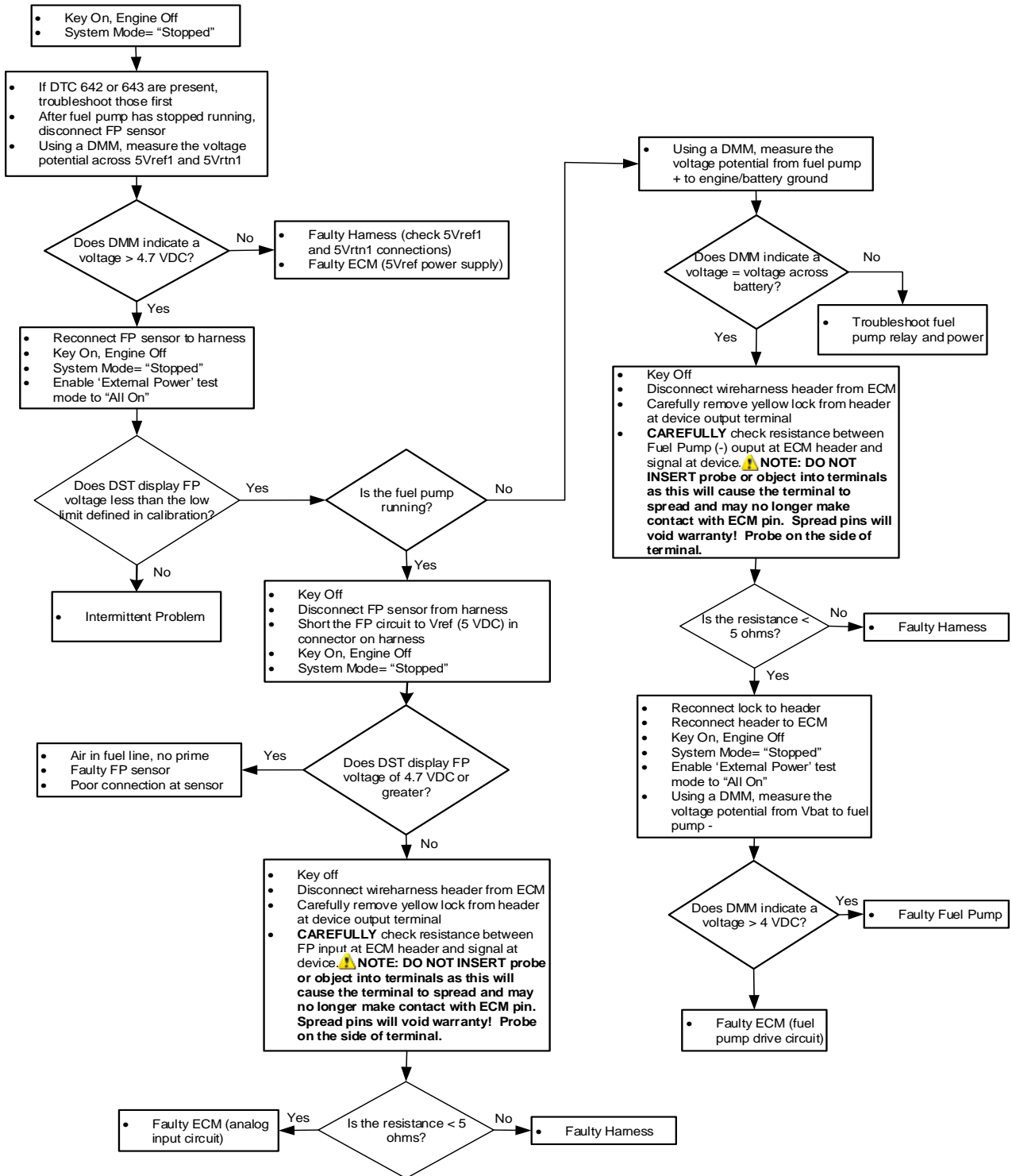

Code			Fault Description
DTC	SPN	FMI	
92	94	3	FP high voltage

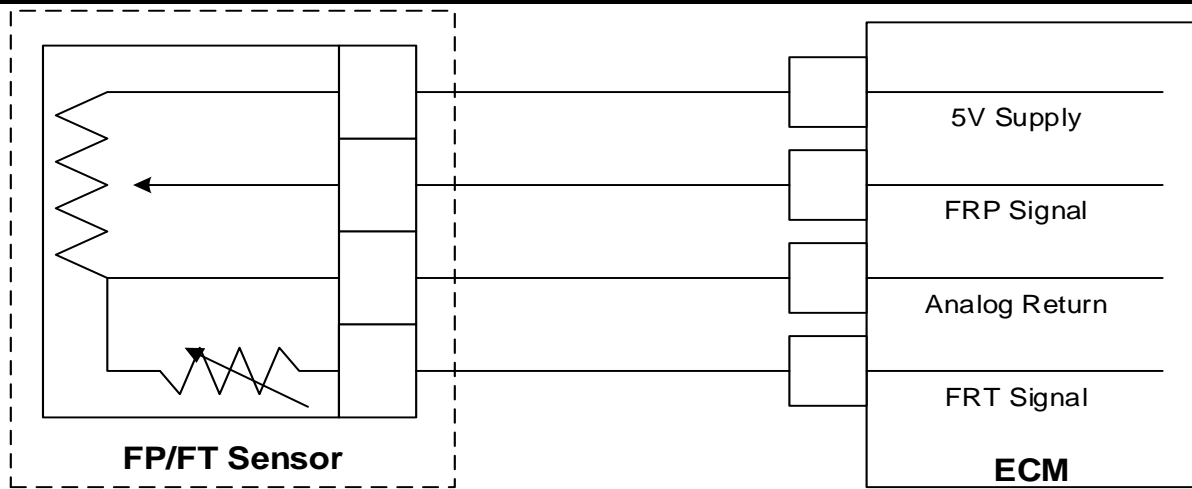

Hardware/Circuit:	Liquid Fuel Pressure and Temperature Sensor
--------------------------	---

Hardware/Circuit Description:	The fuel pressure sensor is installed inline in the gasoline fuel supply line and is used to provide fuel pressure feedback to the ECM. The ECM sets a target rail pressure based on running conditions and then the fuel pump is PWM controlled through a low side driver in the ECM. The fuel pressure sensor feedback is used to determine when the actual rail pressure has reached the target rail pressure.
--------------------------------------	---

Possible Causes:	This fault will set if the signal voltage is higher than the high voltage limit as defined in the diagnostic calibration anytime the engine is running. The limit is generally set to 4.90 VDC. In many cases, this condition is caused by a short-to-power of the FP circuit in the wire harness or a failure of the sensor.
-------------------------	---

DTC 92: Troubleshooting Tree

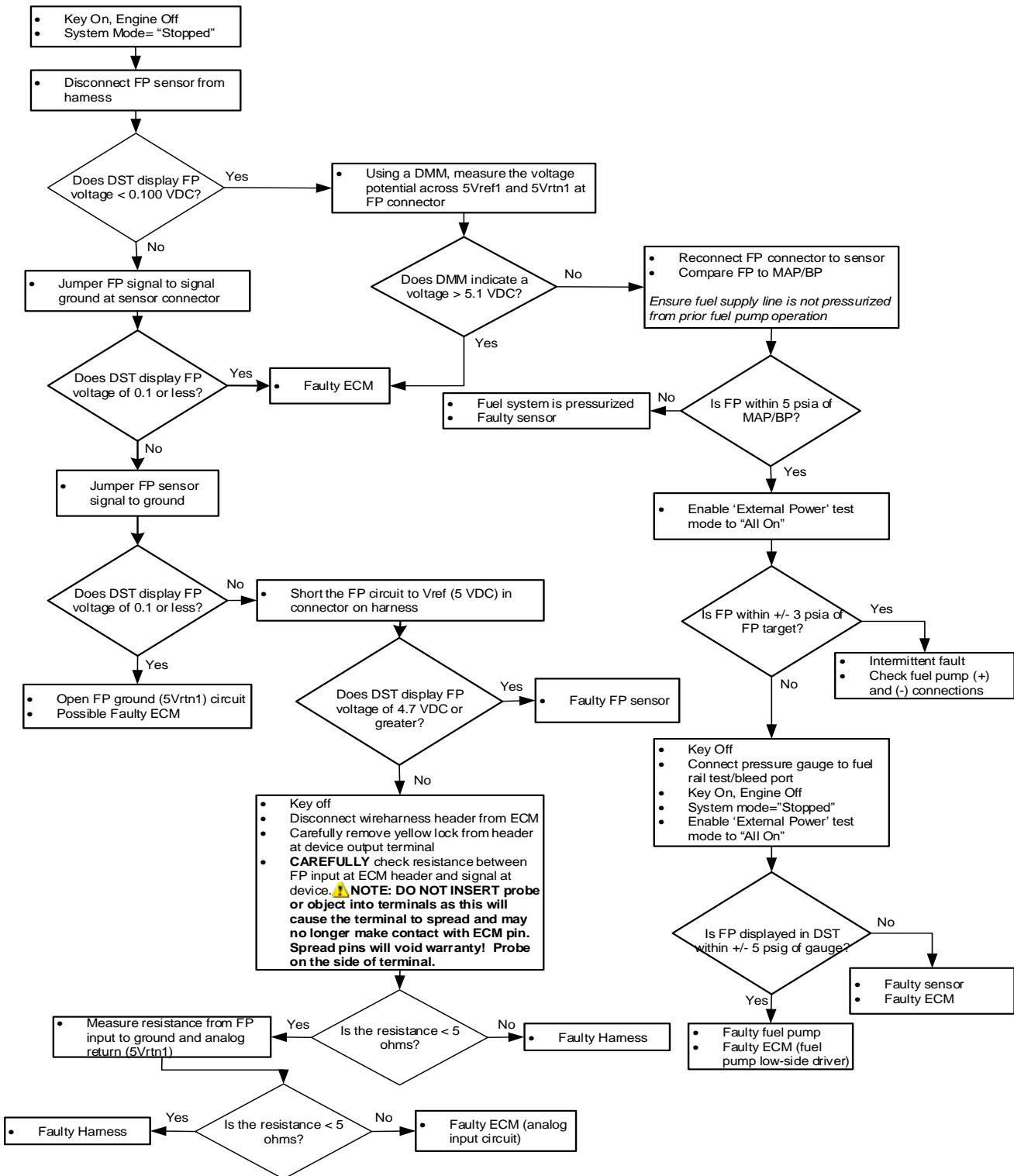

Code			Fault Description
DTC	SPN	FMI	
107	106	4	MAP Low Voltage

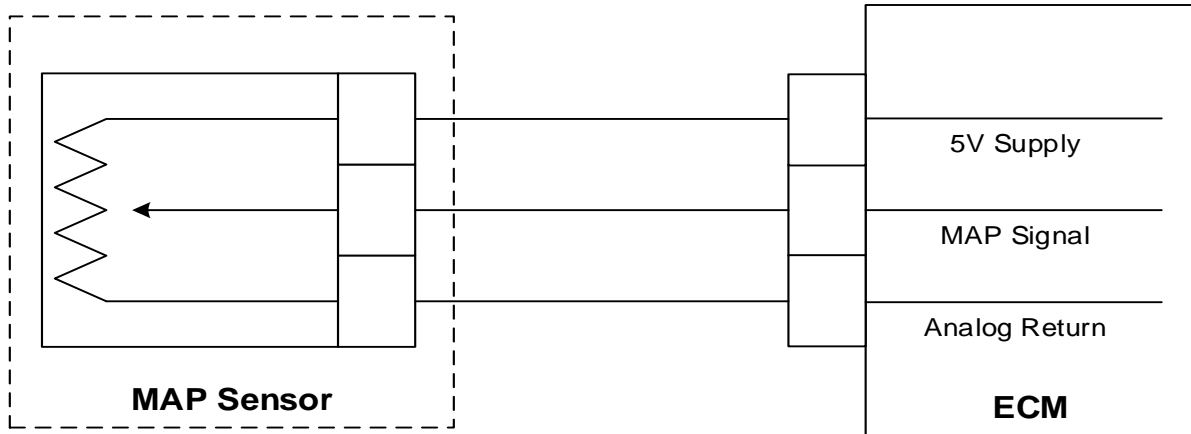

Hardware/Circuit:	Manifold Absolute Pressure Sensor
--------------------------	-----------------------------------

Hardware/Circuit Description:	The Manifold Absolute Pressure sensor is a pressure transducer connected to the intake manifold. It is used to measure the pressure of air in the manifold prior to induction into the engine. The pressure reading is used in conjunction with other inputs to determine the rate of airflow to the engine, which thereby determines the required fuel flow rate.
--------------------------------------	--

Possible Causes:	This fault will set when the MAP sensor voltage feedback is sensed as lower than what the sensor should normally produce as set in the diagnostic calibration. The limit is generally set at 0.10 VDC. In many cases, this condition is caused by the MAP sensor being disconnected from the engine harness, an open-circuit or short-to-ground of the MAP circuit in the wire harness, a loss of sensor reference voltage, or a failure of the sensor. When this fault occurs, the ECM operates in a limp home mode in which an estimated MAP based on TPS feedback is used to fuel the engine. If the MAP sensor is integrated in a TMAP sensor and an IAT High Voltage fault (DTC 113) is also present, the sensor is likely disconnected from the wire harness.
-------------------------	---

DTC 107: Troubleshooting Tree

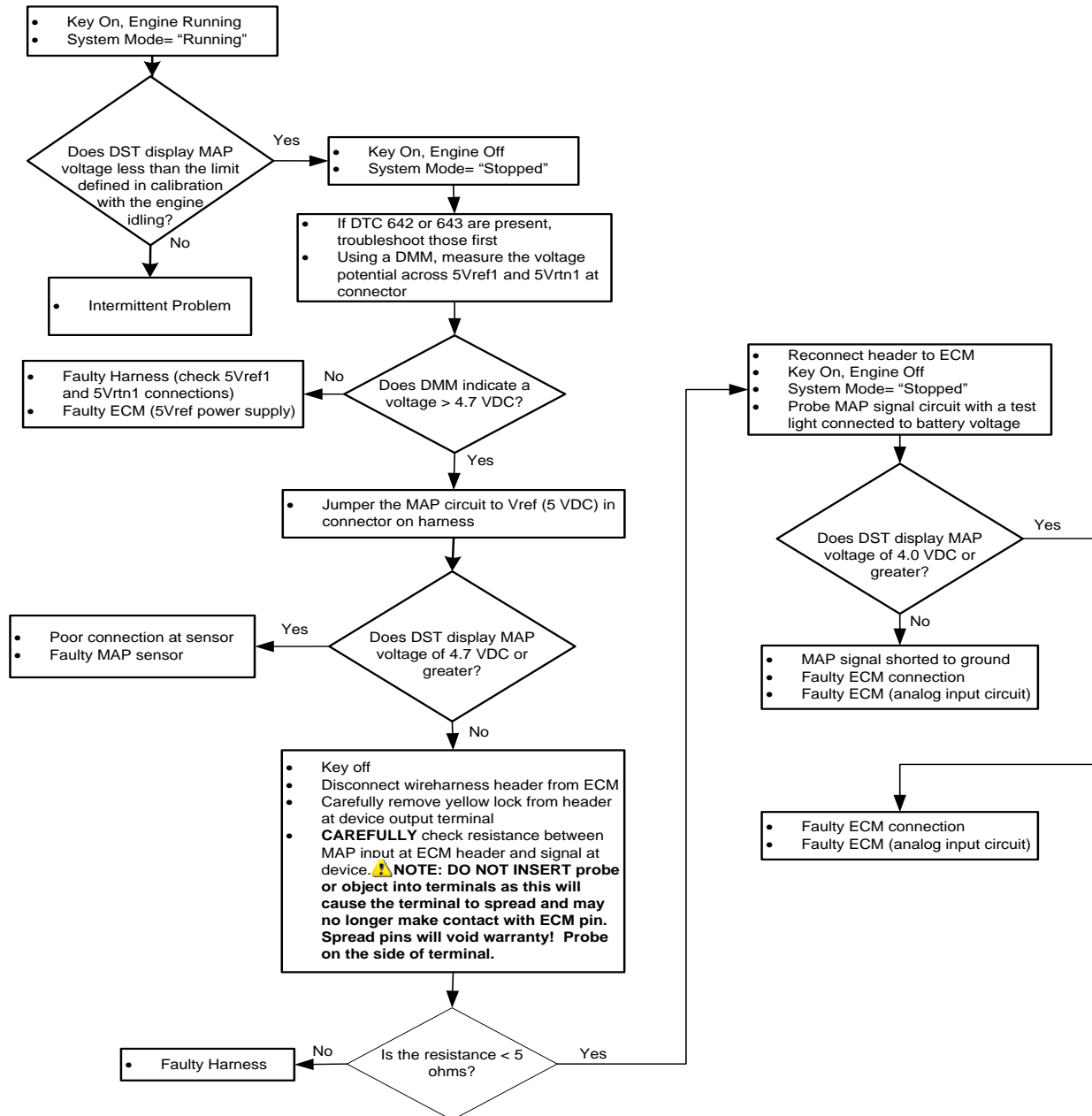

Code			Fault Description
DTC	SPN	FMI	
108	106	16	MAP High Pressure

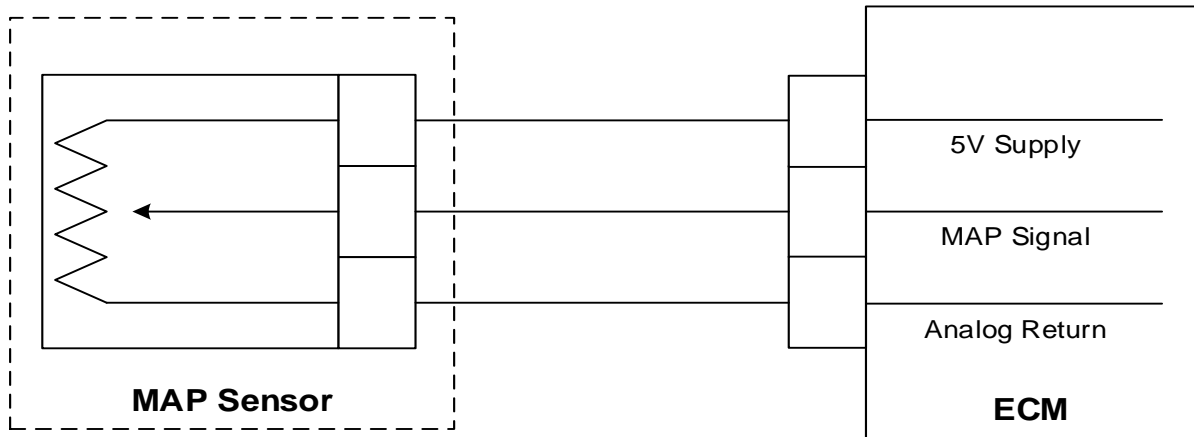

Hardware/Circuit:	Manifold Absolute Pressure Sensor
--------------------------	-----------------------------------

Hardware/Circuit Description:	The Manifold Absolute Pressure sensor is a pressure transducer connected to the intake manifold. It is used to measure the pressure of air in the manifold prior to induction into the engine. The pressure reading is used in conjunction with other inputs to determine the rate of airflow to the engine, which thereby determines the required fuel flow rate.
--------------------------------------	--

Possible Causes:	This fault will set when the MAP reading is higher than it should be for the given TPS, and RPM. When the fault is set the engine will typically operate in a limp home mode using an estimated MAP based on TPS feedback.
-------------------------	--

DTC 108: Troubleshooting Tree

- Key On - Engine On
- System Mode="Running"

If engine idle is rough, unstable, missing or incorrect due to a suspected engine mechanical problem or vacuum leak etc. correct the condition before continuing to use this diagnostic chart.

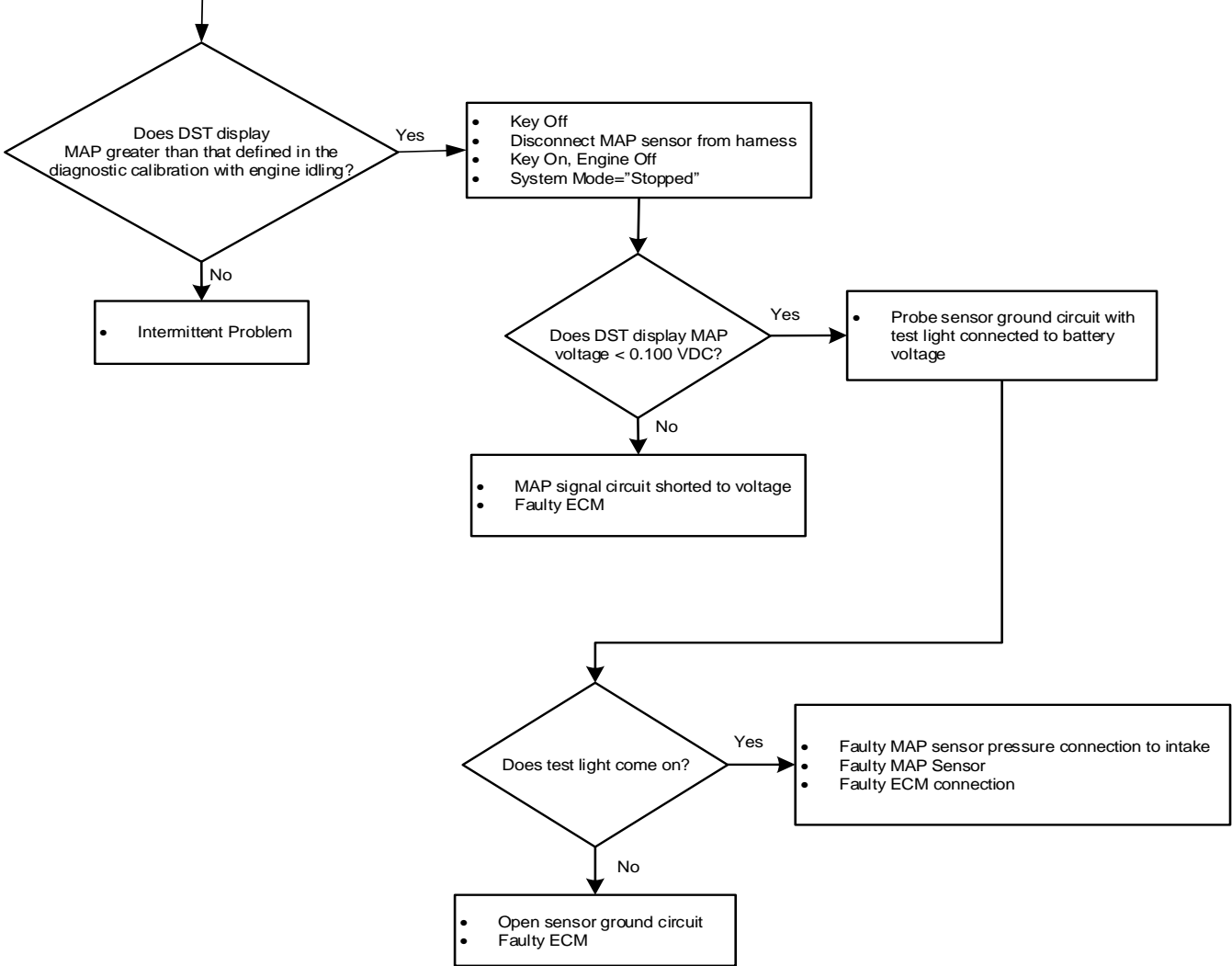

Code			Fault Description
DTC	SPN	FMI	
111	105	15	IAT higher than expected 1

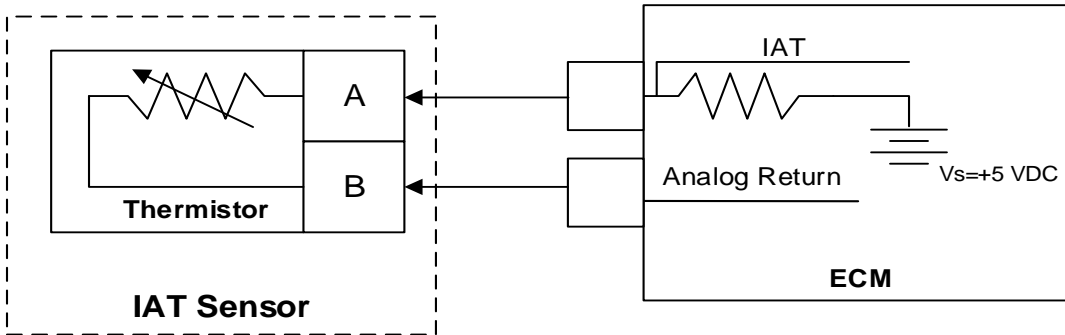

Hardware/Circuit:	Intake Air Temperature Sensor
--------------------------	-------------------------------

Hardware/Circuit Description:	<p>The Intake Air Temperature sensor is a thermistor (temperature sensitive resistor) located in the intake manifold of the engine. It is used to monitor incoming air and the output, in conjunction with other sensors, is used to determine the airflow to the engine. The ECM provides a voltage divider circuit so that when the air is cool, the signal reads higher voltage, and lower when warm.</p> <p>The Manifold Air Temperature is a calculated value based mainly on the IAT sensor at high airflow and influenced more by the ECT/CHT at low airflow. It is used to monitor incoming air and the output, in conjunction with other sensors, is used to determine the airflow to the engine, and ignition timing.</p>
--------------------------------------	---

Possible Causes:	This fault will set if the Intake Air Temperature is greater than the stage 1 limit and the operating condition is at a speed greater than defined in the diagnostic calibration.
-------------------------	---

DTC 111: Diagnostic Aid

Diagnostic Aids

- This fault will set when inlet air is hotter than normal. The most common cause of high inlet air temperature is a result of a problem with routing of the inlet air. Ensure inlet plumbing sources are external, is cool, and is not too close to the exhaust at any point.
- Inspect the inlet air system for cracks or breaks that may allow unwanted underhood air to enter the engine.
- If no problem is found, replace the IAT sensor with a known good part and retest.

Code			Fault Description
DTC	SPN	FMI	
112	105	4	IAT low voltage

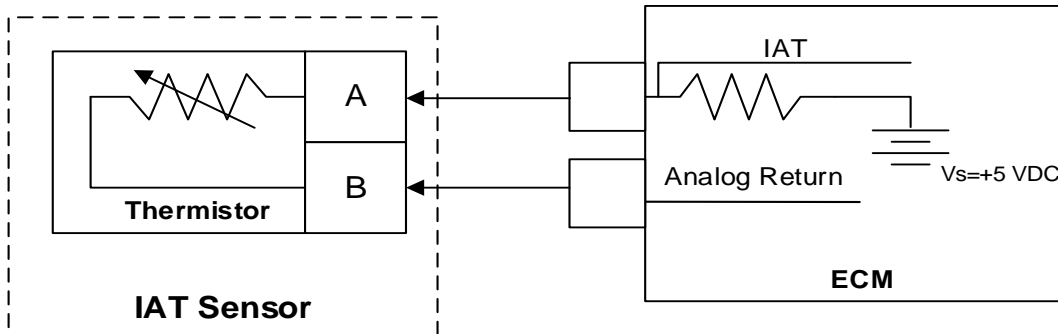

Hardware/Circuit:	Intake Air Temperature Sensor
--------------------------	-------------------------------

Hardware/Circuit Description:	<p>The Intake Air Temperature sensor is a thermistor (temperature sensitive resistor) located in the intake manifold of the engine. It is used to monitor incoming air and the output, in conjunction with other sensors, is used to determine the airflow to the engine. The ECM provides a voltage divider circuit so that when the air is cool, the signal reads higher voltage, and lower when warm.</p> <p>The Manifold Air Temperature is a calculated value based mainly on the IAT sensor at high airflow and influenced more by the ECT/CHT at low airflow. It is used to monitor incoming air and the output, in conjunction with other sensors, is used to determine the airflow to the engine, and ignition timing.</p>
--------------------------------------	---

Possible Causes:	<p>This fault will set if the signal voltage is less than the low voltage limit as defined in the diagnostic calibration anytime the engine is running. The limit is generally set to 0.100 VDC. The ECM will use a default value for the IAT sensor in the event of this fault.</p>
-------------------------	--

DTC 112: Troubleshooting Tree

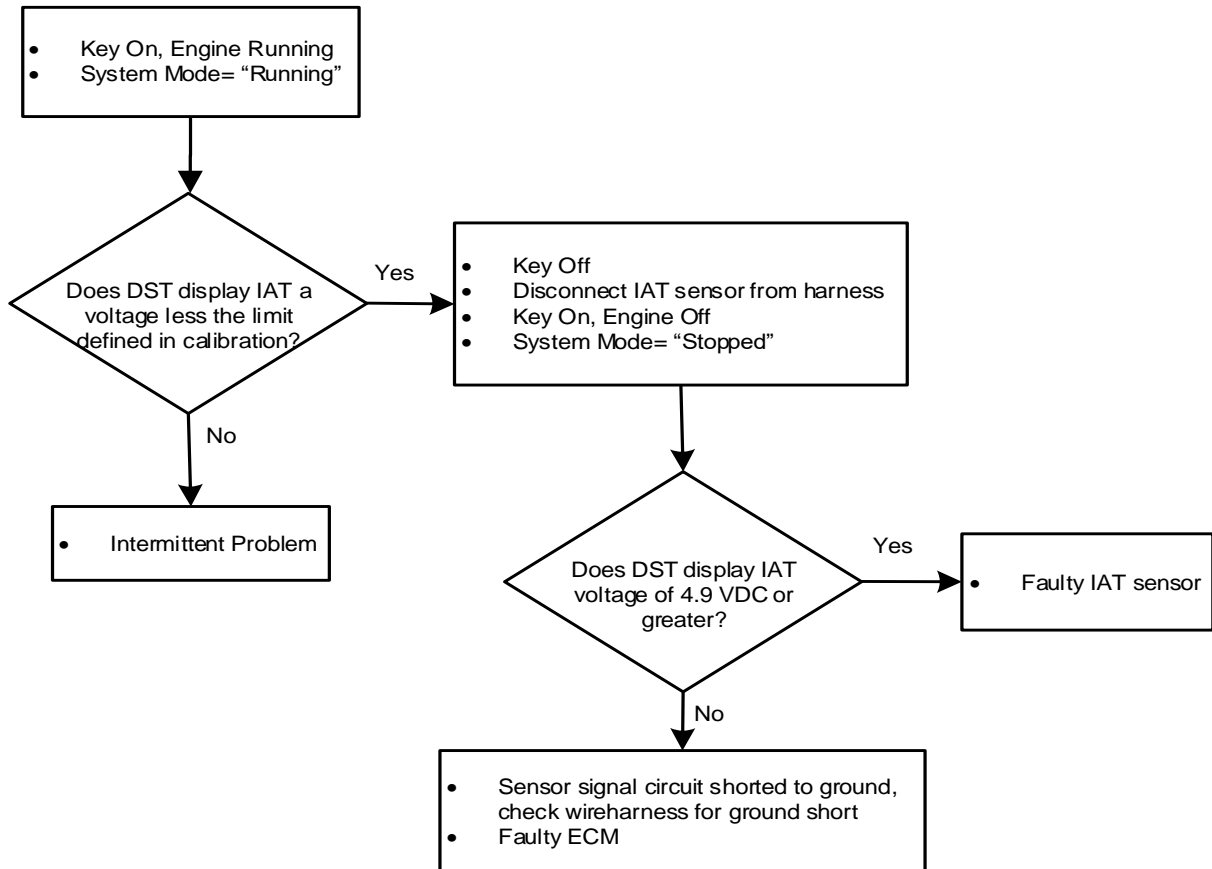

Code			Fault Description
DTC	SPN	FMI	
113	105	3	IAT high voltage

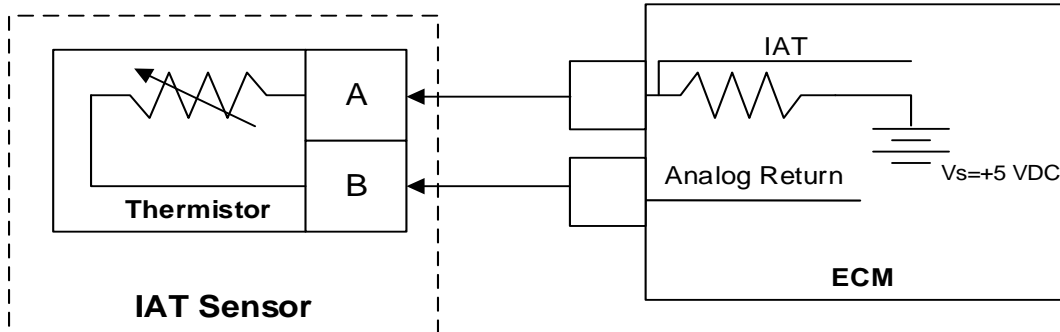

Hardware/Circuit:	Intake Air Temperature Sensor
--------------------------	-------------------------------

Hardware/Circuit Description:	<p>The Intake Air Temperature sensor is a thermistor (temperature sensitive resistor) located in the intake manifold of the engine. It is used to monitor incoming air and the output, in conjunction with other sensors, is used to determine the airflow to the engine. The ECM provides a voltage divider circuit so that when the air is cool, the signal reads higher voltage, and lower when warm.</p> <p>The Manifold Air Temperature is a calculated value based mainly on the IAT sensor at high airflow and influenced more by the ECT/CHT at low airflow. It is used to monitor incoming air and the output, in conjunction with other sensors, is used to determine the airflow to the engine, and ignition timing.</p>
--------------------------------------	---

Possible Causes:	<p>This fault will set if the signal voltage is higher than the high voltage limit as defined in the diagnostic calibration anytime the engine is running. The limit is generally set to 4.90 VDC. In many cases, this condition is caused by the IAT sensor being disconnected from the engine harness, an open-circuit or short-to-power of the IAT circuit in the wireharness, or a failure of the sensor. The ECM will use a default value for the IAT sensor in the event of this fault.</p>
-------------------------	---

DTC 113: Troubleshooting Tree

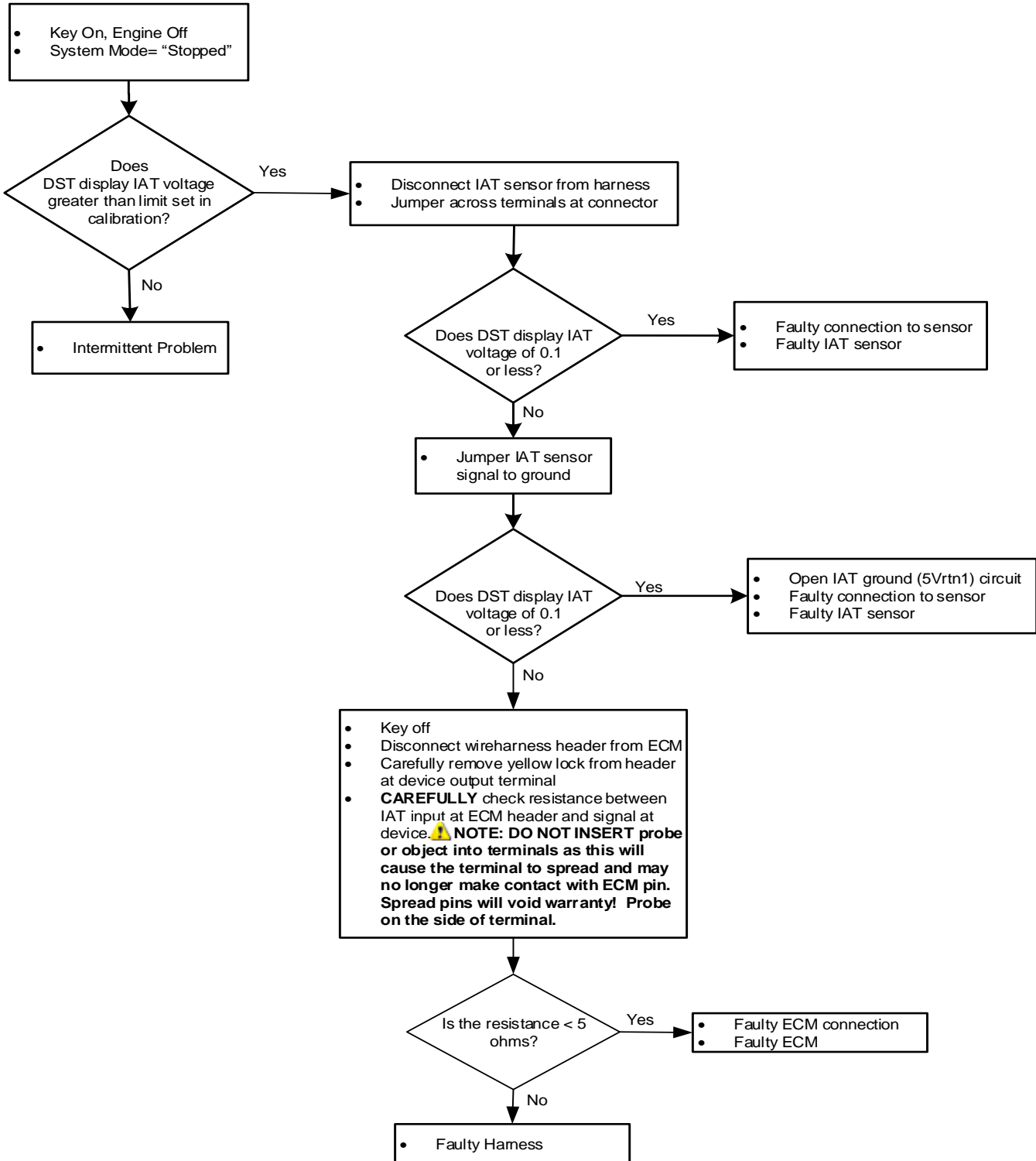

Code			Fault Description
DTC	SPN	FMI	
116	110	15	ECT higher than expected 1

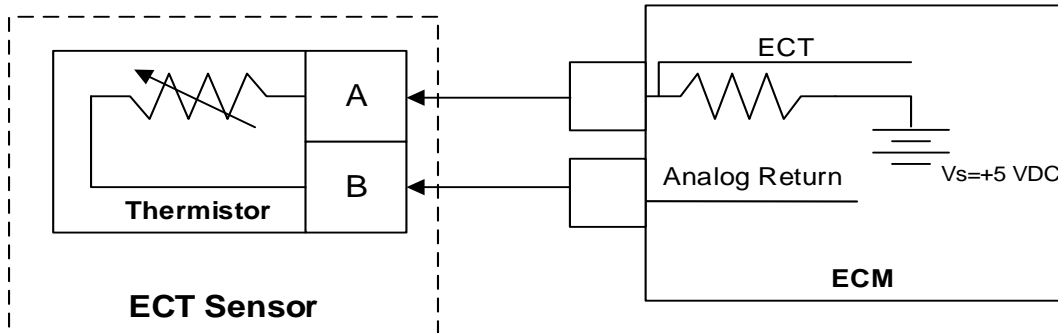

Hardware/Circuit:	Engine Coolant Temperature Sensor
--------------------------	-----------------------------------

Hardware/Circuit Description:	<p>The Engine Coolant Temperature sensor is a thermistor (temperature sensitive resistor) located in the engine coolant. Some engines use a CHT sensor that is located in the coolant in the cylinder head. Some engines use an ECT (Engine Coolant Temperature) sensor that is located in the coolant near the thermostat. If the engine is equipped with a CHT sensor then the ECT value is estimated. If equipped with an ECT sensor then the CHT value is estimated. They are used for engine airflow calculation, ignition timing control, to enable certain features, and for engine protection.</p> <p>The ECM provides a voltage divider circuit so when the sensor reading is cool the sensor reads higher voltage, and lower when warm.</p>
--------------------------------------	---

Possible Causes:	When the coolant exceeds x deg. F and engine RPM exceeds y RPM for the latch time this fault will set, in order to help protect the engine in the event of over temperature.
-------------------------	--

DTC 116: Diagnostic Aids

Diagnostic Aids

- If the “ECT High Voltage” fault is also present, follow the troubleshooting procedures for that fault as it may have caused “ECT Higher Than Expected 1.”
- If the cooling system utilizes an air-to-water heat exchanger (radiator) and fan:
 - Check that the radiator has a proper amount of ethylene glycol/water and that the radiator is not leaking.
 - Ensure that there is no trapped air in the cooling path.
 - Inspect the cooling system (radiator and hoses) for cracks and ensure connections are leak free.
 - Check that the fan is operating properly.
 - Check that the thermostat is not stuck closed.
- If the cooling system utilizes a water-to-water heat exchanger:
 - Check that the heat exchanger has a proper amount of ethylene glycol/water and that the heat exchanger is not leaking.
 - Ensure that there is no trapped air in the cooling path.
 - Inspect the cooling system (radiator and hoses) for cracks and ensure connections are leak free.
 - Check that the raw water pickup is not blocked/restricted by debris and that the hose is tightly connected.
 - Check that the thermostat is not stuck closed.
 - Check that the raw water pump/impeller is tact and that it is not restricted.

Code			Fault Description
DTC	SPN	FMI	
117	110	4	ECT/CHT Low Voltage

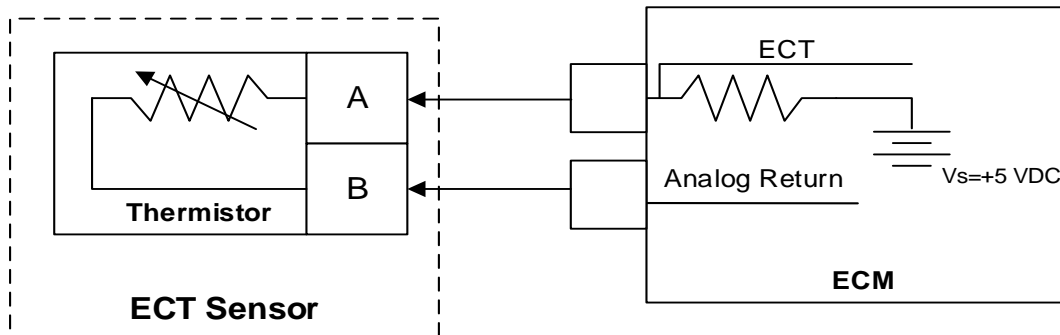

Hardware/Circuit:	Engine Coolant Temperature Sensor
--------------------------	-----------------------------------

Hardware/Circuit Description:	<p>The Engine Coolant Temperature sensor is a thermistor (temperature sensitive resistor) located in the engine coolant. Some engines use a CHT sensor that is located in the coolant in the cylinder head. Some engines use an ECT (Engine Coolant Temperature) sensor that is located in the coolant near the thermostat. If the engine is equipped with a CHT sensor then the ECT value is estimated. If equipped with an ECT sensor then the CHT value is estimated. They are used for engine airflow calculation, ignition timing control, to enable certain features, and for engine protection.</p> <p>The ECM provides a voltage divider circuit so when the sensor reading is cool the sensor reads higher voltage, and lower when warm.</p>
--------------------------------------	---

Possible Causes:	<p>This fault will set if the signal voltage is less than the limit defined in the diagnostic calibration anytime the engine is running. The limit is generally set to 0.10 VDC. The ECM will use a default value for the CHT/ECT sensor in the event of this fault.</p>
-------------------------	--

DTC 117: Troubleshooting Tree

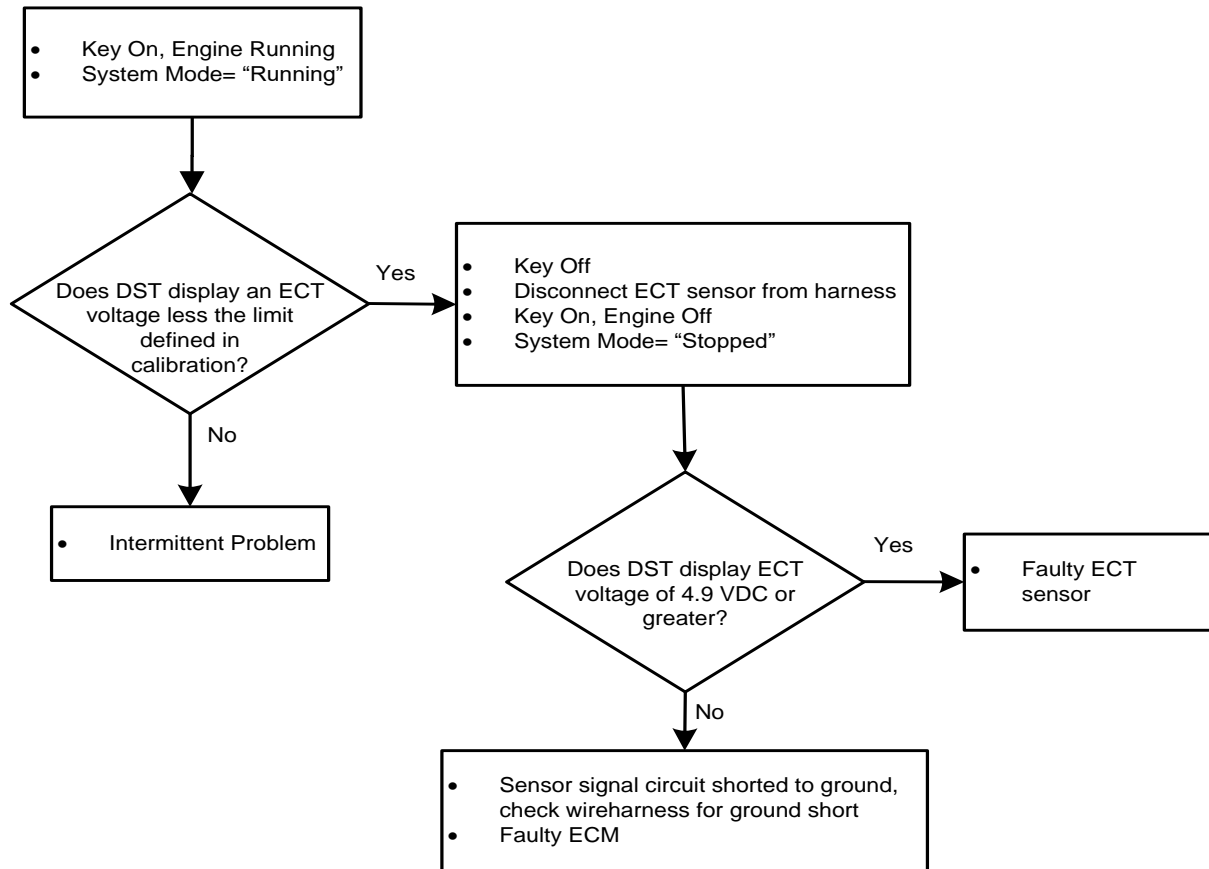

Code			Fault Description
DTC	SPN	FMI	
118	110	3	ECT/CHT High Voltage

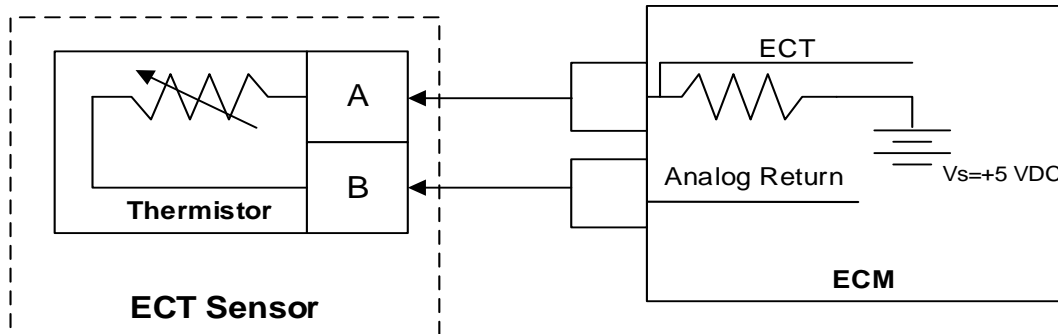

Hardware/Circuit:	Engine Coolant Temperature Sensor
--------------------------	-----------------------------------

Hardware/Circuit Description:	<p>The Engine Coolant Temperature sensor is a thermistor (temperature sensitive resistor) located in the engine coolant. Some engines use a CHT sensor that is located in the coolant in the cylinder head. Some engines use an ECT (Engine Coolant Temperature) sensor that is located in the coolant near the thermostat. If the engine is equipped with a CHT sensor then the ECT value is estimated. If equipped with an ECT sensor then the CHT value is estimated. They are used for engine airflow calculation, ignition timing control, to enable certain features, and for engine protection.</p> <p>The ECM provides a voltage divider circuit so when the sensor reading is cool the sensor reads higher voltage, and lower when warm.</p>
--------------------------------------	---

Possible Causes:	<p>This fault will set if the signal voltage is higher than the high voltage limit as defined in the diagnostic calibration anytime the engine is running. The limit is generally set to 4.90 VDC. In many cases, this condition is caused by the CHT/ECT sensor being disconnected from the engine harness, an open-circuit or short-to-power of the CHT/ECT circuit in the wire harness, or a failure of the sensor. The ECM will use a default value for the CHT/ECT sensor in the event of this fault.</p>
-------------------------	--

DTC 118: Troubleshooting Tree

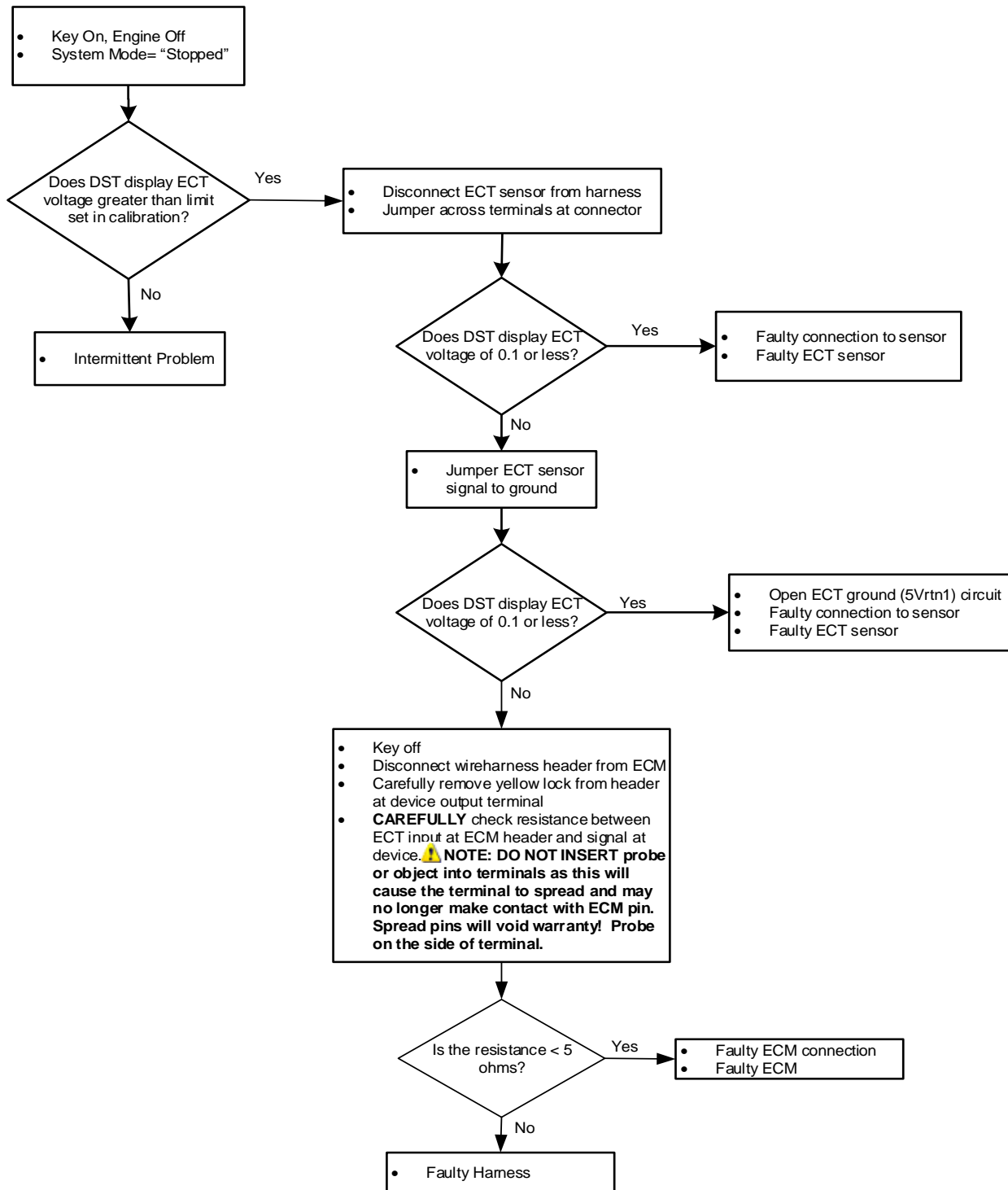

Code			Fault Description
DTC	SPN	FMI	
121	51	1	TPS1 lower than TPS2

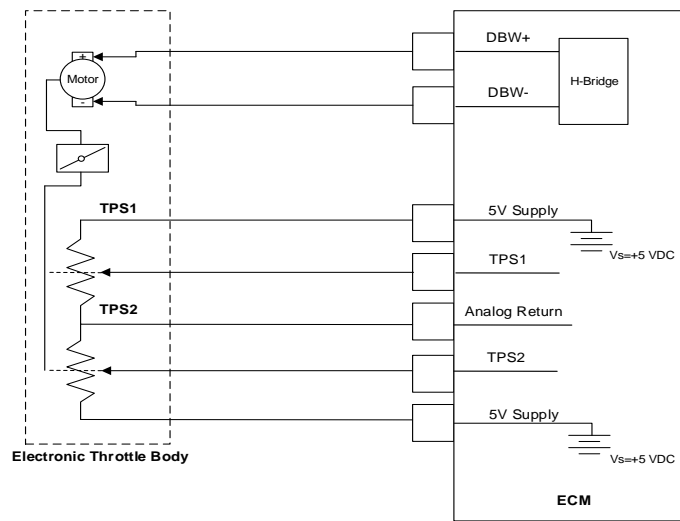

Hardware/Circuit:	Throttle Body-Throttle Position Sensor 1 & 2 (electronic throttle body only)
--------------------------	--

Hardware/Circuit Description:	<p>The throttle controls the airflow through the engine, directly affecting the power output of the engine. When the throttle is electronically controlled in an Electronic Throttle Body it can be used to control the idle stability and limit engine speed based on operating conditions.</p> <p>The integrated Throttle Position Sensor uses either a variable resistor and voltage divider circuit or a non-contact HE sensor to determine throttle plate position. The output of the TPS is linear with angular position. The TPS input(s) provide angular position feedback of the throttle plate. In mechanical throttle bodies this sensor is typically used to help improve return-to-idle governing when working in combination with an Idle Air Control motor. In an Electronic Throttle Body multiple position feedback sensors (usually two counteracting potentiometers/hall-effects) are used to perform speed governing with improved safety and redundancy.</p>
--------------------------------------	---

Possible Causes:	This fault will set if TPS1 % is lower than TPS2 % by the amount defined in the diagnostic calibration. At this point the throttle is considered to be out of specification, or there is a problem with the TPS signal circuit.
-------------------------	---

DTC 121: Troubleshooting Tree

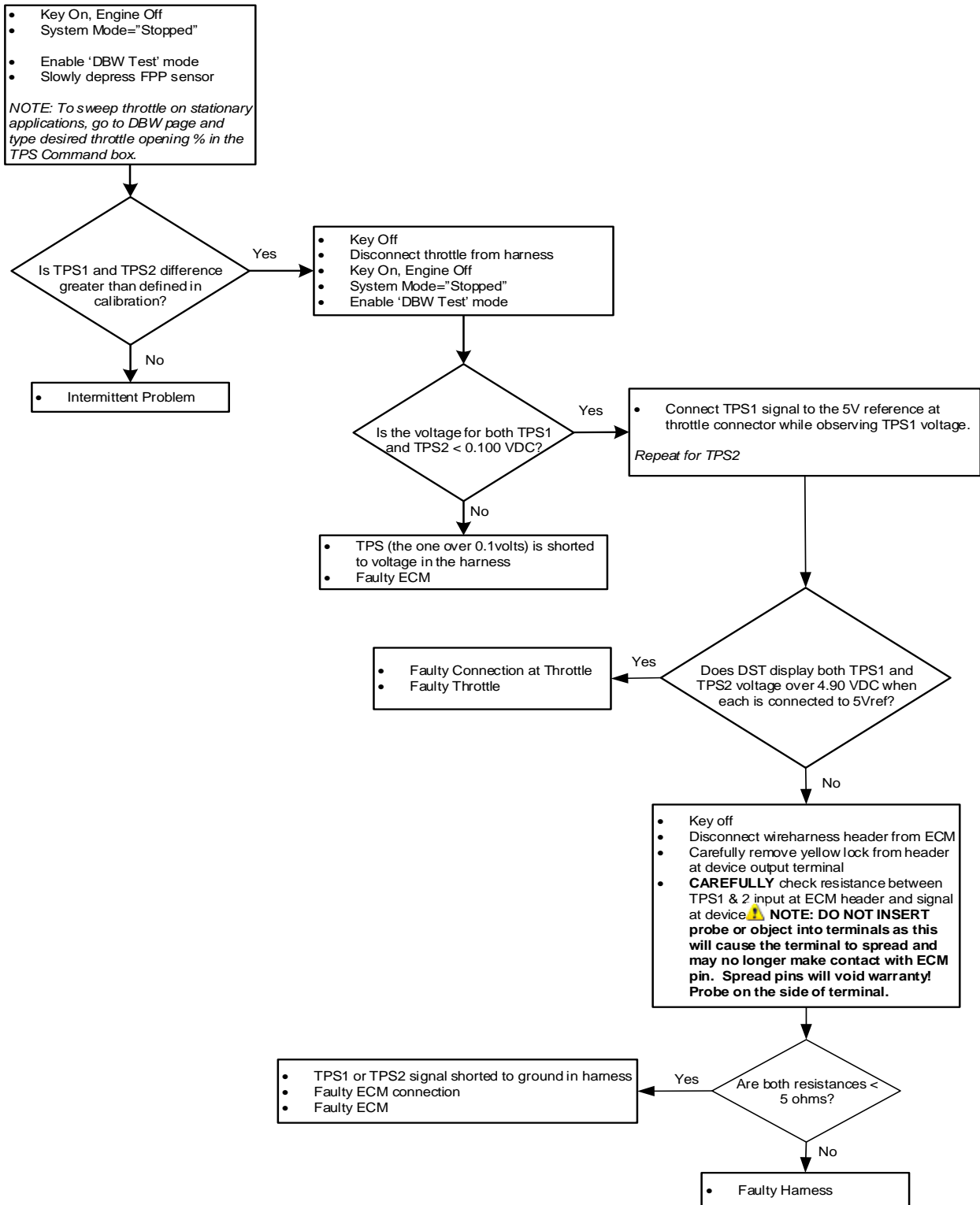

Code			Fault Description
DTC	SPN	FMI	
122	51	4	TPS1 low voltage

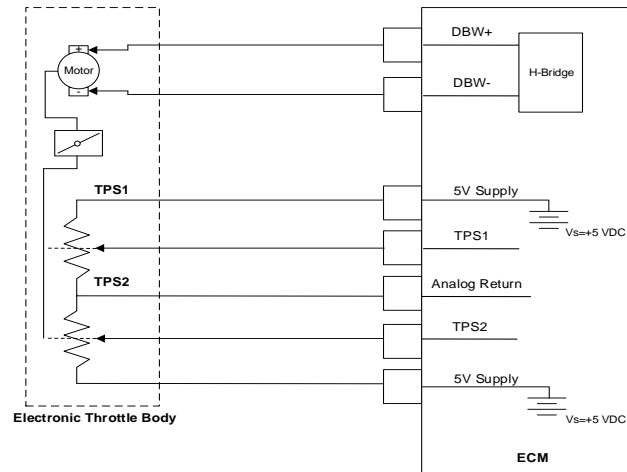

Hardware/Circuit:	Throttle Body-Throttle Position Sensor 1 & 2 (electronic throttle body only)
--------------------------	--

Hardware/Circuit Description:	<p>The throttle controls the airflow through the engine, directly affecting the power output of the engine. When the throttle is electronically controlled in an Electronic Throttle Body it can be used to control the idle stability and limit engine speed based on operating conditions.</p> <p>The integrated Throttle Position Sensor uses either a variable resistor and voltage divider circuit or a non-contact HE sensor to determine throttle plate position. The output of the TPS is linear with angular position. The TPS input(s) provide angular position feedback of the throttle plate. In mechanical throttle bodies this sensor is typically used to help improve return-to-idle governing when working in combination with an Idle Air Control motor. In an Electronic Throttle Body multiple position feedback sensors (usually two counteracting potentiometers/hall-effects) are used to perform speed governing with improved safety and redundancy.</p>
--------------------------------------	---

Possible Causes:	<p>This fault will set if TPS[N] voltage is lower than the low voltage limit as defined in the diagnostic calibration at any operating condition while the engine is cranking or running. The limit is generally set to 4.90 VDC. In many cases, this condition is caused by the TPS sensor being disconnected from the engine harness, an open-circuit or short-to-ground of the TPS circuit in the wire harness, or a failure of the sensor. This fault should be configured to trigger an engine shutdown and the engine will not start with this fault active.</p>
-------------------------	--

DTC 122: Troubleshooting Tree

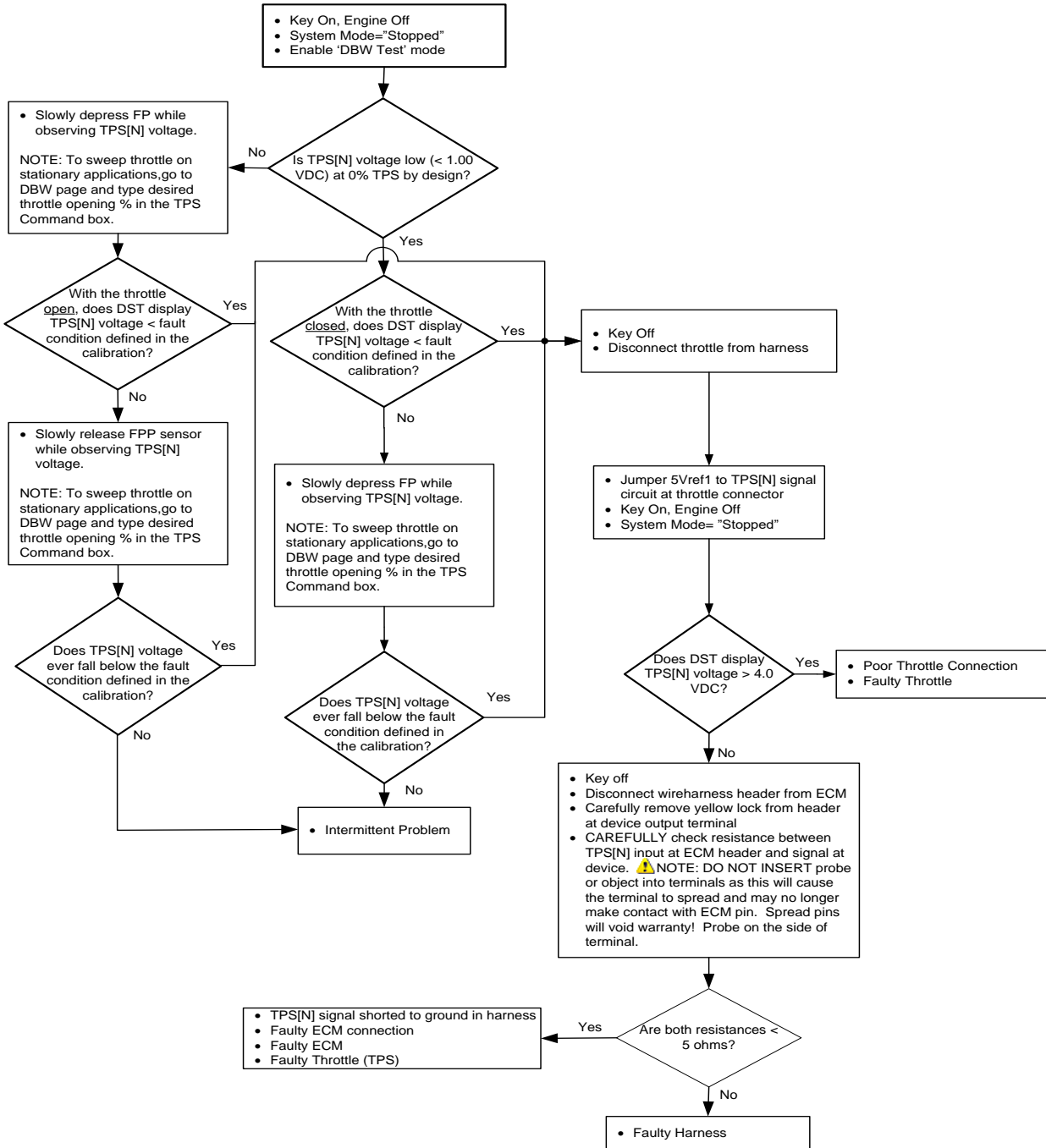

Code			Fault Description
DTC	SPN	FMI	
123	51	3	TPS1 high voltage

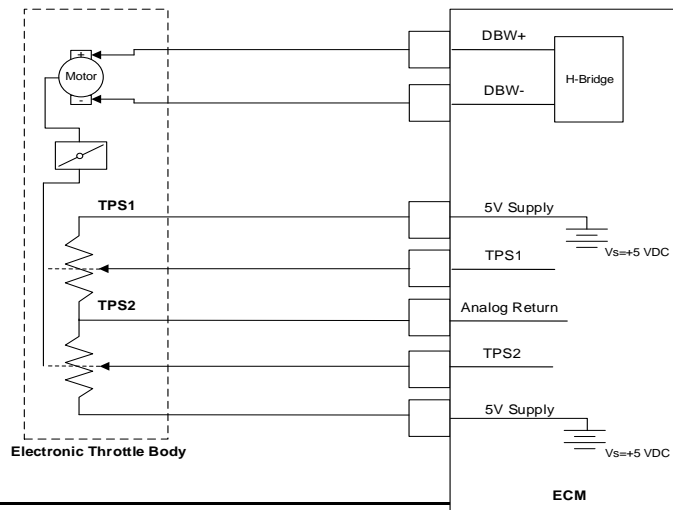

Hardware/Circuit:	Throttle Body-Throttle Position Sensor 1 & 2 (electronic throttle body only)
--------------------------	--

Hardware/Circuit Description:	<p>The throttle controls the airflow through the engine, directly affecting the power output of the engine. When the throttle is electronically controlled in an Electronic Throttle Body it can be used to control the idle stability and limit engine speed based on operating conditions.</p> <p>The integrated Throttle Position Sensor uses either a variable resistor and voltage divider circuit or a non-contact HE sensor to determine throttle plate position. The output of the TPS is linear with angular position. The TPS input(s) provide angular position feedback of the throttle plate. In mechanical throttle bodies this sensor is typically used to help improve return-to-idle governing when working in combination with an Idle Air Control motor. In an Electronic Throttle Body multiple position feedback sensors (usually two counteracting potentiometers/hall-effects) are used to perform speed governing with improved safety and redundancy.</p>
--------------------------------------	---

Possible Causes:	<p>This fault will set if TPS[N] voltage is higher than the limit set in the diagnostic calibration at any operating condition while the engine is cranking or running. The limit is generally set to 4.90 VDC. In many cases, this condition is caused by a short-to-power of the TPS circuit in the wire harness or a failure of the sensor.</p>
-------------------------	--

DTC 123: Troubleshooting Tree

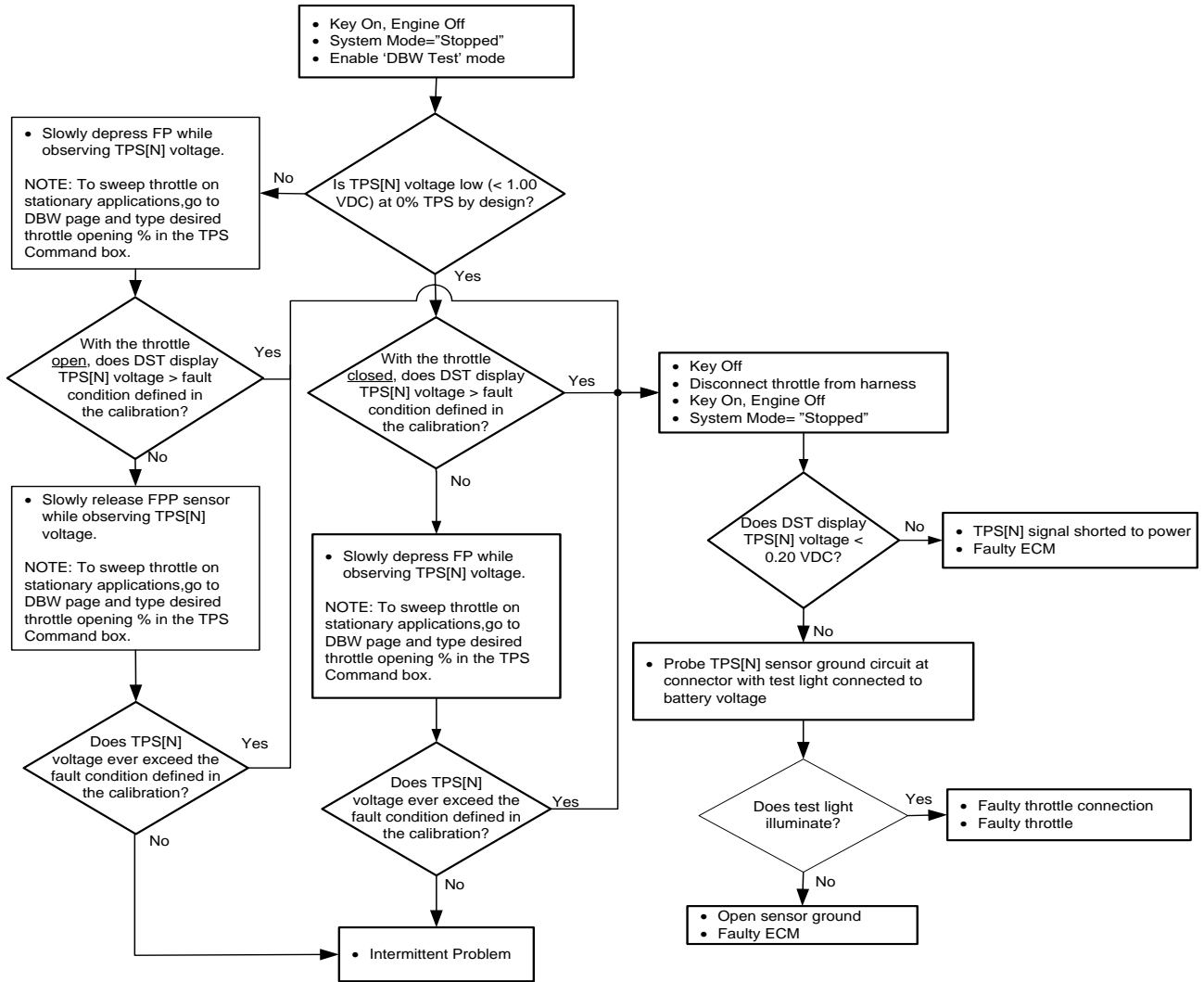

Code			Fault Description
DTC	SPN	FMI	
127	105	0	IAT higher than expected 2

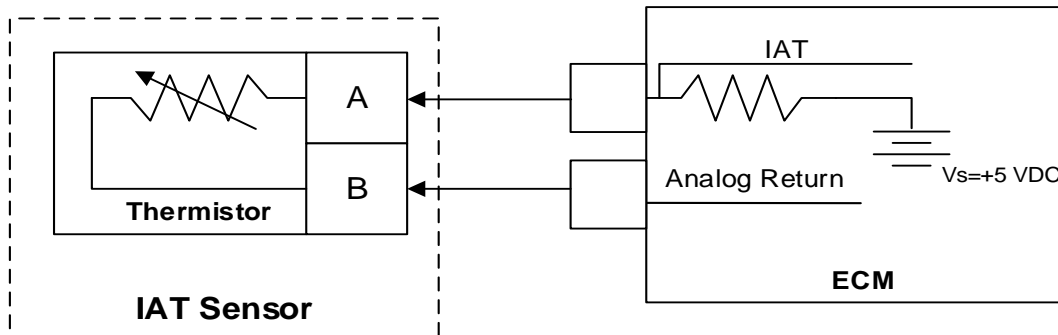

Hardware/Circuit:	Intake Air Temperature Sensor
--------------------------	-------------------------------

Hardware/Circuit Description:	<p>The Intake Air Temperature sensor is a thermistor (temperature sensitive resistor) located in the intake manifold of the engine. It is used to monitor incoming air and the output, in conjunction with other sensors, is used to determine the airflow to the engine. The ECM provides a voltage divider circuit so that when the air is cool, the signal reads higher voltage, and lower when warm.</p> <p>The Manifold Air Temperature is a calculated value based mainly on the IAT sensor at high airflow and influenced more by the ECT/CHT at low airflow. It is used to monitor incoming air and the output, in conjunction with other sensors, is used to determine the airflow to the engine, and ignition timing.</p>
--------------------------------------	---

Possible Causes:	<p>This fault will set if the Intake Air Temperature is greater than the stage 2 limit and engine speed is greater than defined in the diagnostic calibration. Generally, a severe course of action will be set to prevent possible damage to the engine, specifically due to knock or detonation which cannot be sensed on some engines due to the lack of knock sensors. During this active fault, maximum throttle position is limited and a visual/audible warning will be activated.</p>
-------------------------	---

DTC 127: Diagnostic Aids

Diagnostic Aids

- This fault will set when inlet air is hotter than normal. The most common cause of high inlet air temperature is a result of a problem with routing of the inlet air. Ensure inlet plumbing sources are external, is cool, and is not too close to the exhaust at any point.
- Inspect the inlet air system for cracks or breaks that may allow unwanted under-hood air to enter the engine.
- If no problem is found, replace the IAT sensor with a known good part and retest.

Code			Fault Description
DTC	SPN	FMI	
129	108	1	BP low pressure

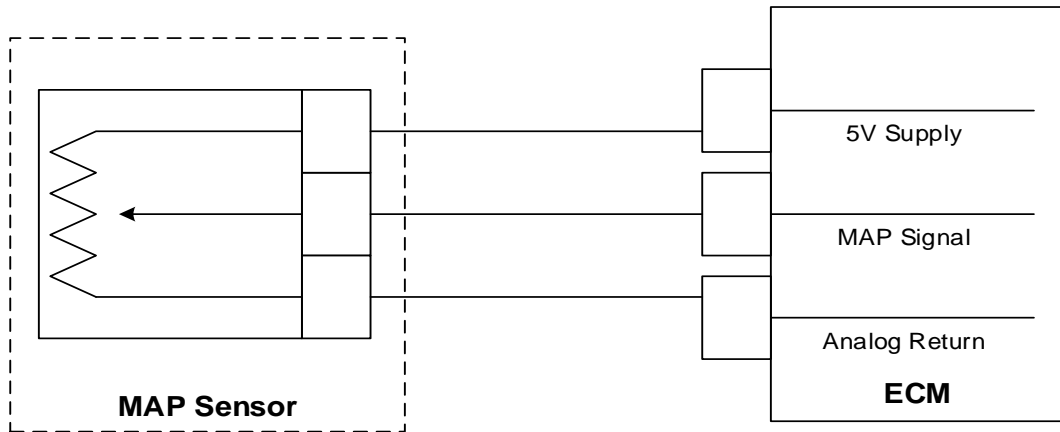

Hardware/Circuit:	Barometric Temperature / Manifold Absolute Pressure Sensor
--------------------------	--

Hardware/Circuit Description:	Barometric Pressure is estimated from the MAP sensor at key-on and in some calibrations during low speed/high load operation as defined in the engine's calibration. The barometric pressure value is used for fuel and airflow calculations and equivalence ratio targets based on altitude.
--------------------------------------	---

Possible Causes:	This fault sets if the barometric pressure is lower than the minimum set pressure (psia) as defined in the diagnostic calibration. In the event of an active fault, the MIL is illuminated for the remainder of the key on cycle, an audible warning and/or a secondary warning lamp is activated, and the Adaptive Learn function is disabled to prevent improper learning and population of the table.
-------------------------	--

DTC 129: Troubleshooting Tree

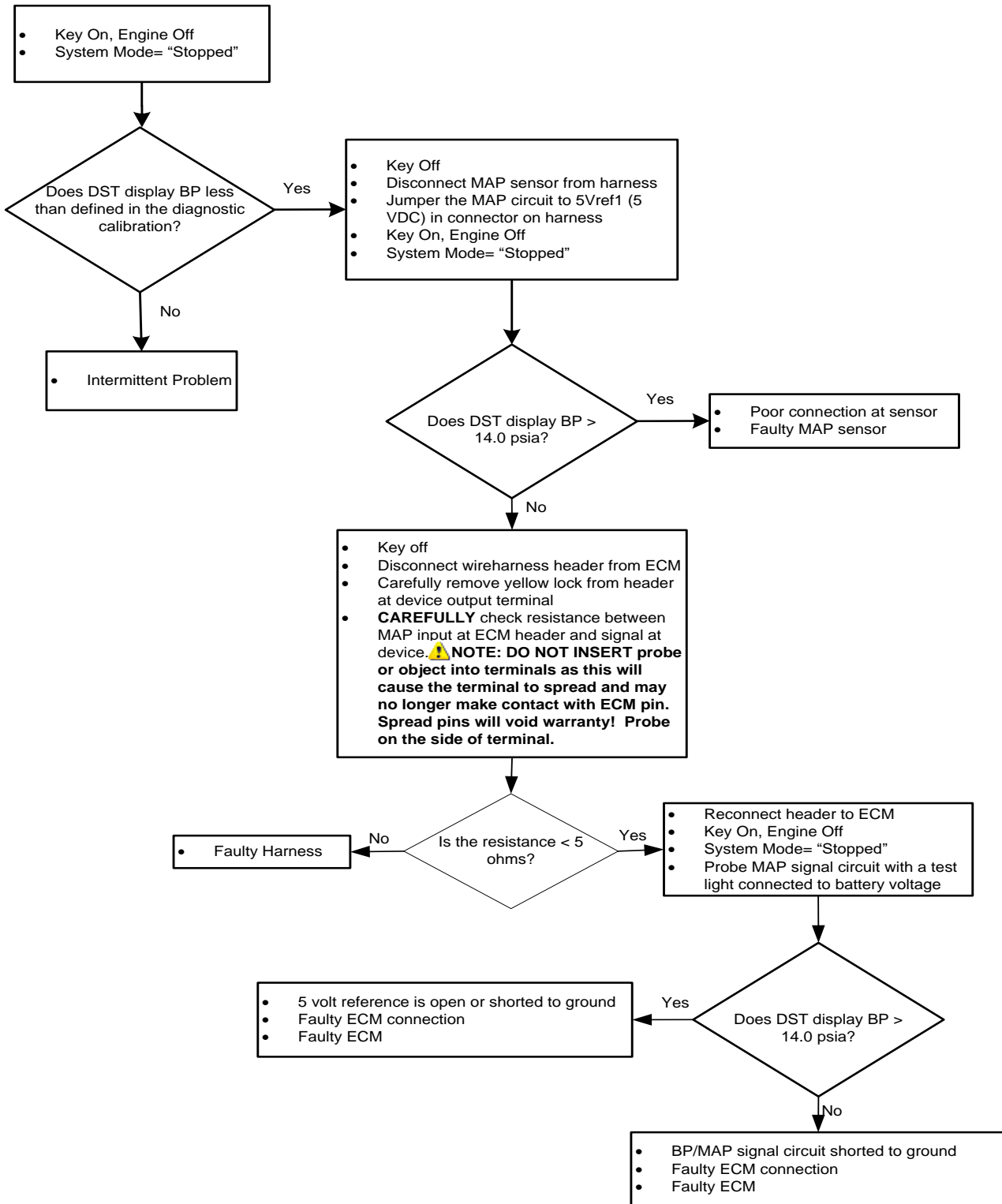

Code			Fault Description
DTC	SPN	FMI	
134	3217	5	EGO open/lazy pre-cat 1

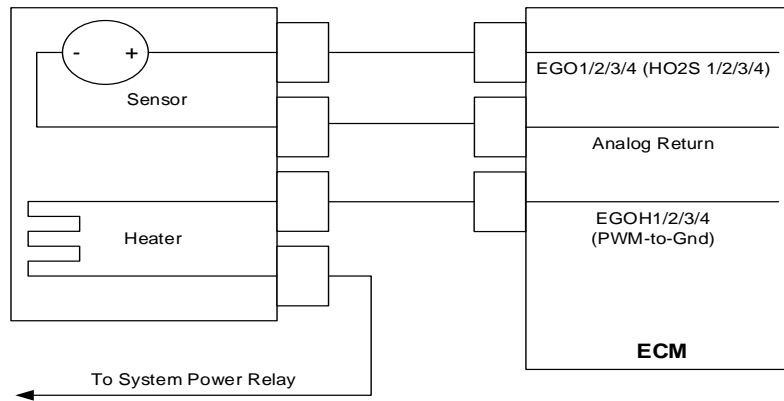

Hardware/Circuit:	Heated or Universal Exhaust Gas Oxygen Sensor (Bank and Position Assignment as Defined in Calibration)
--------------------------	---

Hardware/Circuit Description:	The HEGO/HO2S sensor is a switching-type sensor about stoichiometry that measures the oxygen content present in the exhaust to determine if the fuel flow to the engine is correct. A UEGO sensor measures the exhaust content across a wide-range of air-fuel ratios with a linear analog output proportional to lambda/equivalence ratio/air-fuel ratio. In either case, if there is a deviation between the expected reading and the actual reading, fuel flow is precisely adjusted using the Closed Loop multiplier and then “learned” with the Adaptive multiplier. The multipliers only update when the system is in either “CL Active” or “CL + Adapt” control modes.
--------------------------------------	---

Possible Causes:	This fault will set if the sensor element is cold, non-responsive, or inactive for x seconds as defined in the diagnostic calibration. Cold, non-responsive, or inactive are determined based on two criteria 1) a measurement of the feedback sense element (zirconia) to determine its temperature or 2) a lack of change in sensor feedback.
-------------------------	---

DTC 134: Troubleshooting Tree

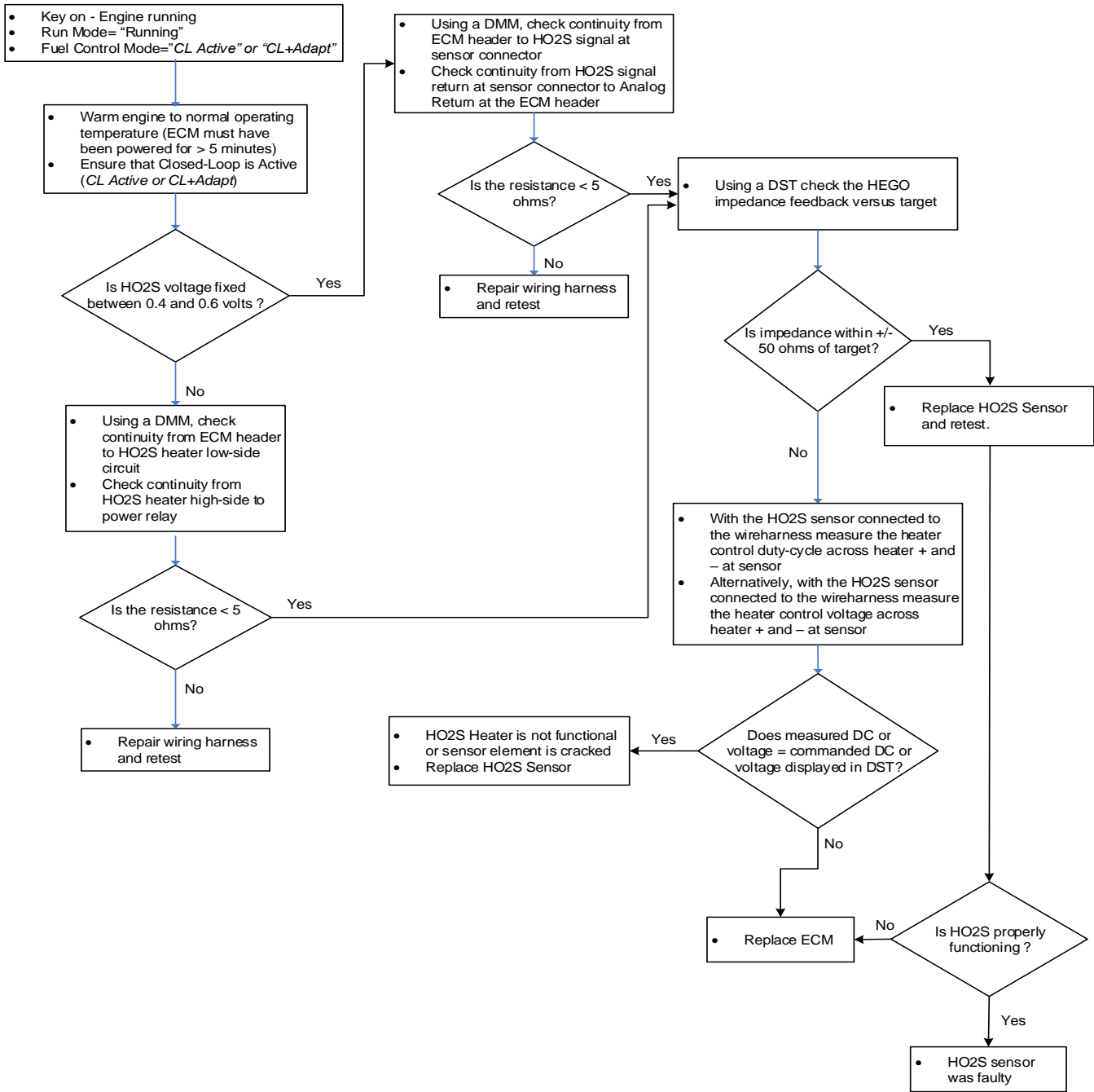

Code			Fault Description
DTC	SPN	FMI	
140	3256	5	EGO open/lazy post-cat 1

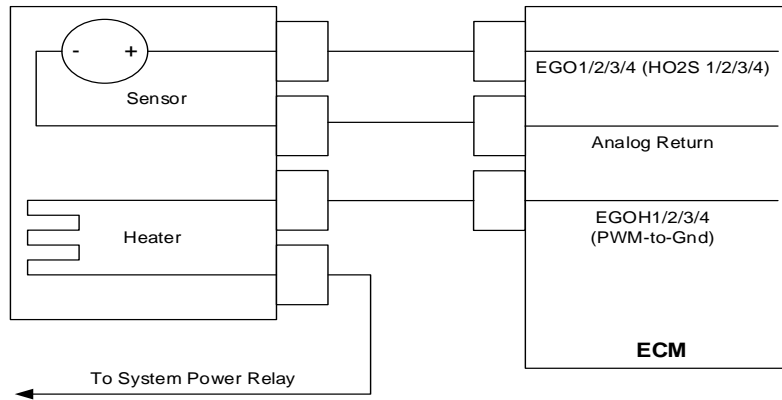

Hardware/Circuit:	Heated or Universal Exhaust Gas Oxygen Sensor (Bank and Position Assignment as Defined in Calibration)
--------------------------	---

Hardware/Circuit Description:	The HEGO/HO2S sensor is a switching-type sensor about stoichiometry that measures the oxygen content present in the exhaust to determine if the fuel flow to the engine is correct. A UEGO sensor measures the exhaust content across a wide-range of air-fuel ratios with a linear analog output proportional to lambda/equivalence ratio/air-fuel ratio. In either case, if there is a deviation between the expected reading and the actual reading, fuel flow is precisely adjusted using the Closed Loop multiplier and then "learned" with the Adaptive multiplier. The multipliers only update when the system is in either "CL Active" or "CL + Adapt" control modes.
--------------------------------------	---

Possible Causes:	This fault will set if the sensor element is cold, non-responsive, or inactive for x seconds as defined in the diagnostic calibration. Cold, non-responsive, or inactive are determined based on two criteria 1) a measurement of the feedback sense element (zirconia) to determine its temperature or 2) a lack of change in sensor feedback.
-------------------------	---

DTC 140: Troubleshooting Tree

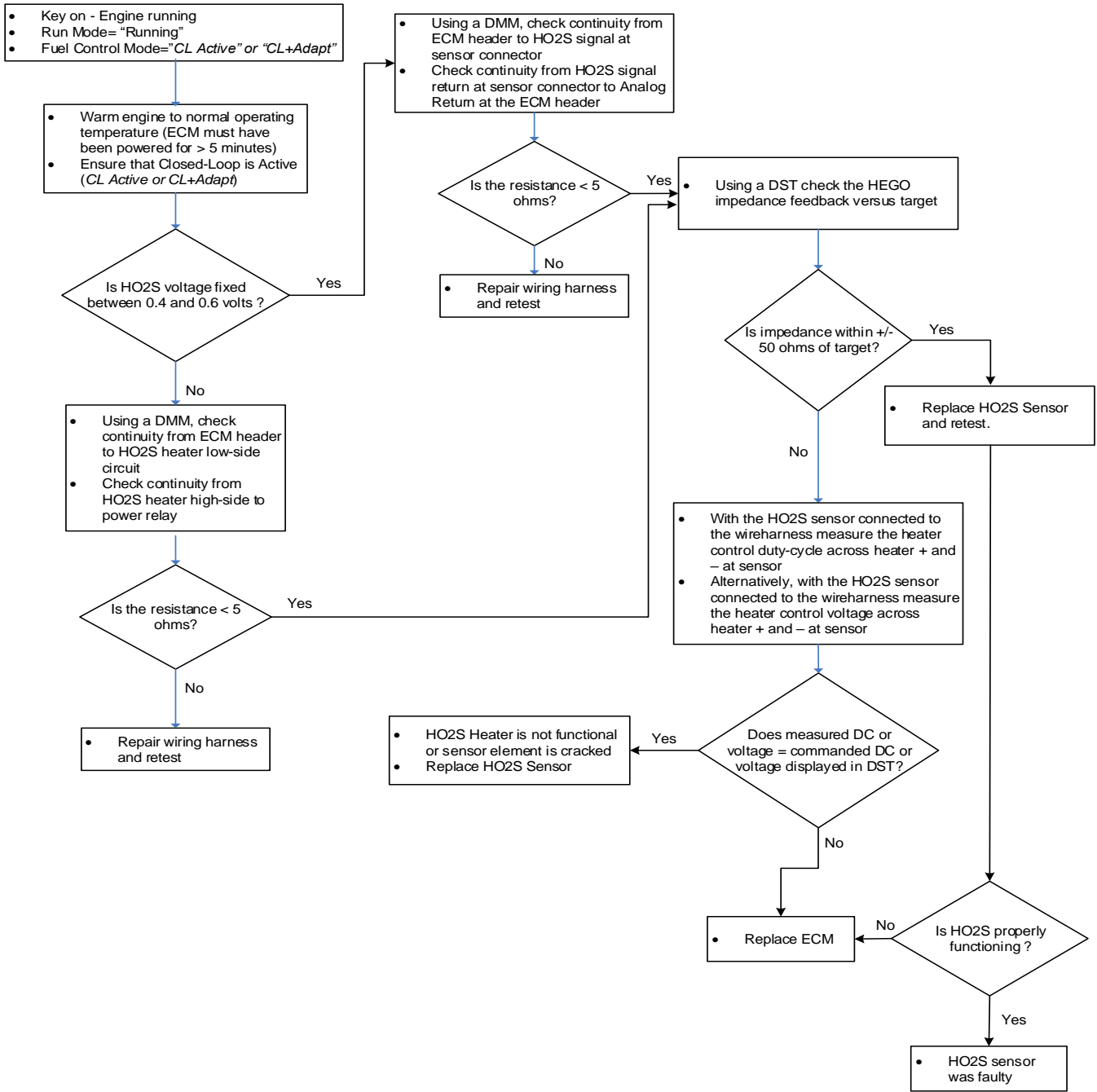

Code			Fault Description
DTC	SPN	FMI	
154	3227	5	EGO open/lazy pre-cat 2/post-cat 1

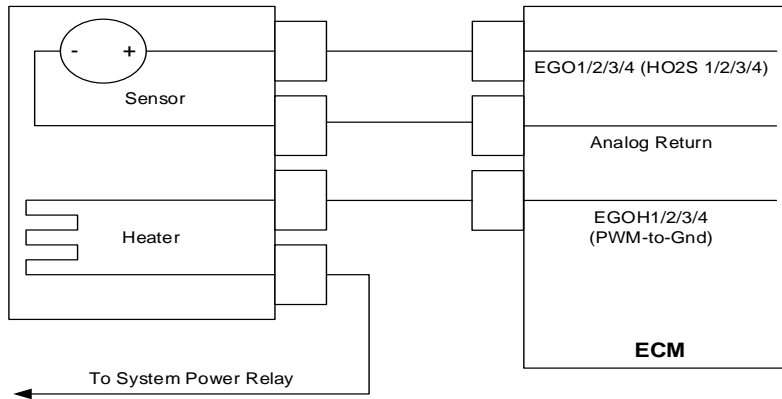

Hardware/Circuit:	Heated or Universal Exhaust Gas Oxygen Sensor (Bank and Position Assignment as Defined in Calibration)
--------------------------	---

Hardware/Circuit Description:	The HEGO/HO2S sensor is a switching-type sensor about stoichiometry that measures the oxygen content present in the exhaust to determine if the fuel flow to the engine is correct. A UEGO sensor measures the exhaust content across a wide-range of air-fuel ratios with a linear analog output proportional to lambda/equivalence ratio/air-fuel ratio. In either case, if there is a deviation between the expected reading and the actual reading, fuel flow is precisely adjusted using the Closed Loop multiplier and then "learned" with the Adaptive multiplier. The multipliers only update when the system is in either "CL Active" or "CL + Adapt" control modes.
--------------------------------------	---

Possible Causes:	This fault will set if the sensor element is cold, non-responsive, or inactive for x seconds as defined in the diagnostic calibration. Cold, non-responsive, or inactive are determined based on two criteria 1) a measurement of the feedback sense element (zirconia) to determine its temperature or 2) a lack of change in sensor feedback.
-------------------------	---

DTC 154: Troubleshooting Tree

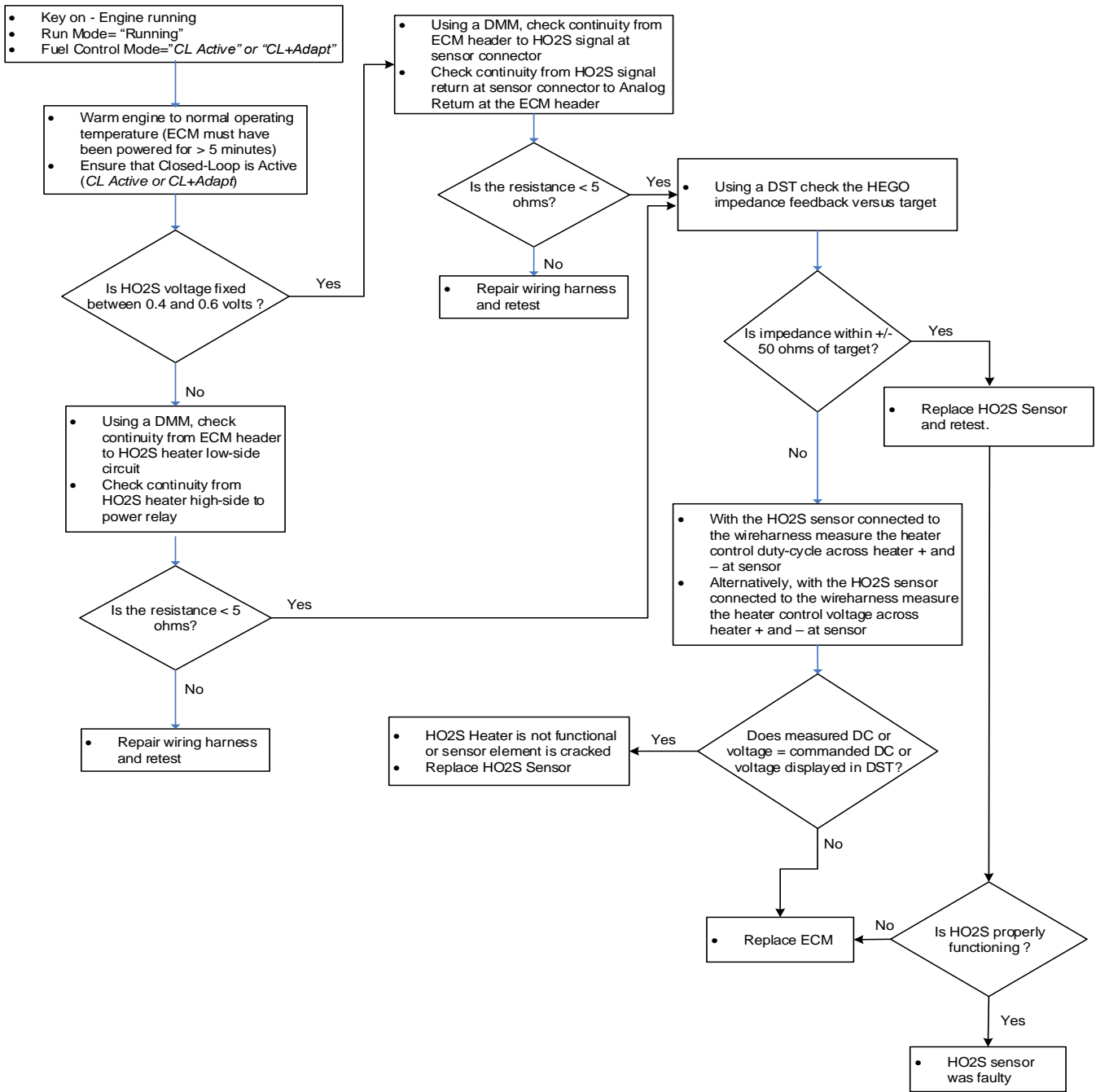

Code			Fault Description
DTC	SPN	FMI	
160	3266	5	EGO open/lazy post-cat 2

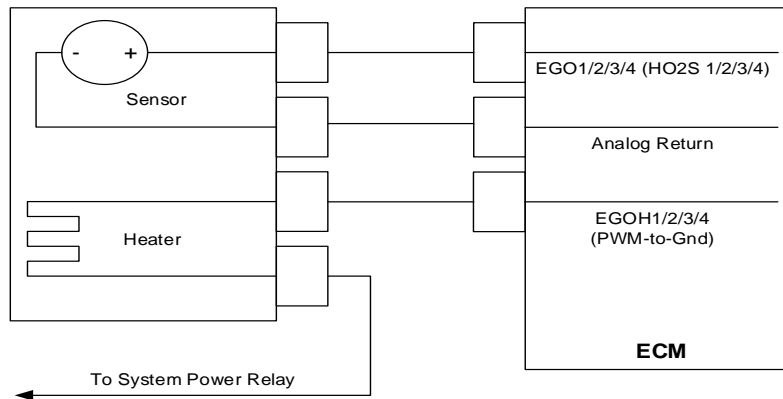

Hardware/Circuit:	Heated or Universal Exhaust Gas Oxygen Sensor (Bank and Position Assignment as Defined in Calibration)
--------------------------	---

Hardware/Circuit Description:	The HEGO/HO2S sensor is a switching-type sensor about stoichiometry that measures the oxygen content present in the exhaust to determine if the fuel flow to the engine is correct. A UEGO sensor measures the exhaust content across a wide-range of air-fuel ratios with a linear analog output proportional to lambda/equivalence ratio/air-fuel ratio. In either case, if there is a deviation between the expected reading and the actual reading, fuel flow is precisely adjusted using the Closed Loop multiplier and then "learned" with the Adaptive multiplier. The multipliers only update when the system is in either "CL Active" or "CL + Adapt" control modes.
--------------------------------------	---

Possible Causes:	This fault will set if the sensor element is cold, non-responsive, or inactive for x seconds as defined in the diagnostic calibration. Cold, non-responsive, or inactive are determined based on two criteria 1) a measurement of the feedback sense element (zirconia) to determine its temperature or 2) a lack of change in sensor feedback.
-------------------------	---

DTC 160: Troubleshooting Tree

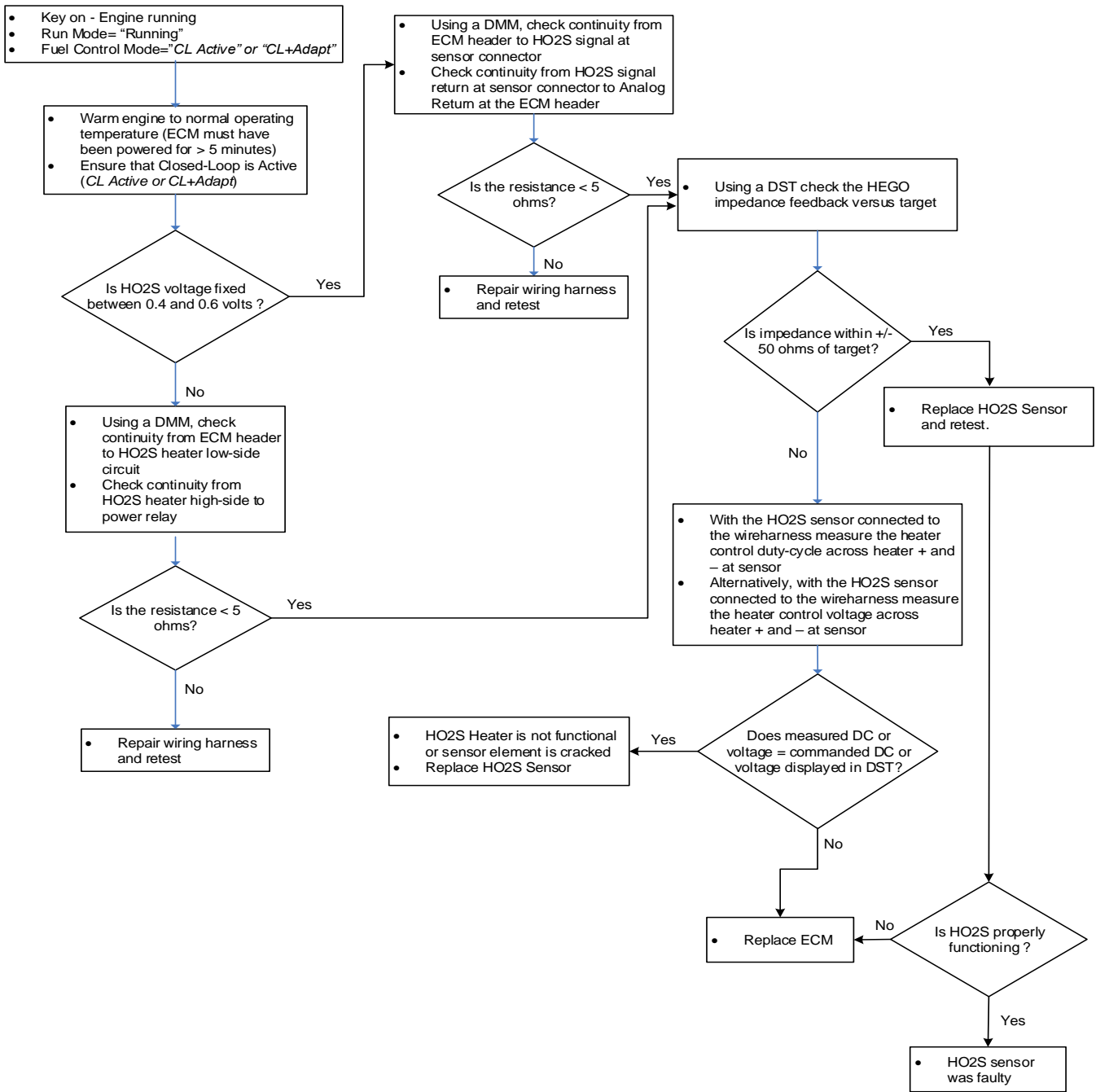

Code			Fault Description
DTC	SPN	FMI	
171	4237	0	AL high gasoline bank1

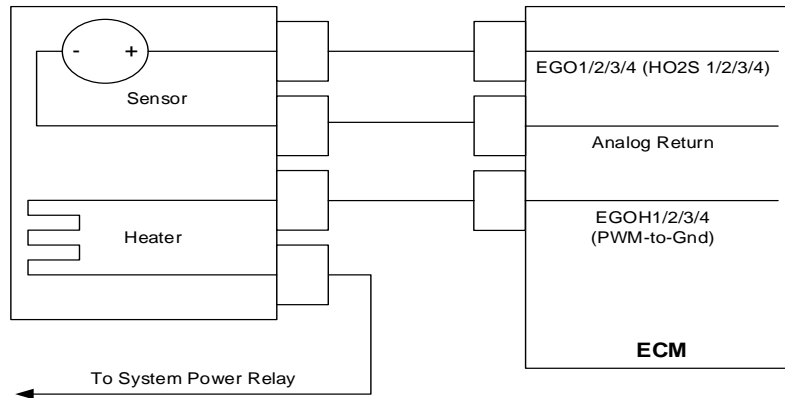

Hardware/Circuit:	Heated or Universal Exhaust Gas Oxygen Sensor (Bank 1-Sensor 1/Bank 1-Before Catalyst) (Bank 2-Sensor 1/Bank 1-Before Catalyst)
--------------------------	---

Hardware/Circuit Description:	<p>The HEGO/HO₂S sensor is a switching-type sensor around stoichiometry that measures the oxygen content present in the exhaust to determine if the fuel flow to the engine is correct. A UEGO sensor measures the exhaust content across a wide-range of air-fuel ratios with a linear output proportional to lambda/equivalence ratio/air-fuel ratio. In either case, if there is a deviation between the expected reading and the actual reading, fuel flow is precisely adjusted for each bank using the Closed Loop multiplier and then “learned” with the Adaptive multiplier. The multipliers only update when the system is in either “CL Active” or “CL + Adapt” control modes.</p> <p>The purpose of the Adaptive Learn fuel multiplier is to adjust fuel flow due to variations in fuel composition, engine wear, engine-to-engine build variances, and component degradation.</p>
--------------------------------------	--

Possible Causes:	<p>This fault sets if the Adaptive multiplier exceeds the high limit of normal operation indicating that the engine is operating lean (excess oxygen) and requires more fuel than allowed by corrections. Often high positive fueling corrections are a function of one or more of the following conditions: 1) exhaust leaks upstream or near the HEGO sensor, 2) reduced fuel supply pressure to the fuel injection system, 3) a non-responsive HEGO/UEGO sensor, and/or 3) an injector that is stuck closed.</p>
-------------------------	---

DTC 171: Diagnostic Aid

NOTE: If any other DTCs are present, diagnose those first.

- Oxygen Sensor Wire - Sensor may be mis-positioned contacting the exhaust. Check for short to ground between harness and sensor and on sensor harness.
- Vacuum Leaks - Large vacuum leaks and crankcase leaks can cause a lean exhaust condition at light load.
- Injectors - System will be lean if an injector driver or driver circuit fails. The system will also be lean if an injector fails in a closed manner or is dirty.
- Fuel Pressure - System will be lean if fuel pressure is too low. Check fuel pressure in the fuel rail during key-on, engine off and during normal operating conditions.
- Air in Fuel - If the fuel return hose/line is too close to the fuel supply pickup in the fuel tank, air may become entrapped in the pump or supply line causing a lean condition and driveability problems.
- Exhaust Leaks - If there is an exhaust leak, outside air can be pulled into the exhaust and past the O2 sensor causing a false lean condition.
- Fuel Quality - A drastic variation in fuel quality may cause the system to be lean including oxygenated fuels.
- System Grounding - ECM and engine must be grounded to the battery with very little resistance allowing for proper current flow. Faulty grounds can cause current supply issues resulting in many undesired problems.

If all tests are OK, replace the HO2S sensor with a known good part and retest.

Code			Fault Description
DTC	SPN	FMI	
172	4237	1	AL low gasoline bank1

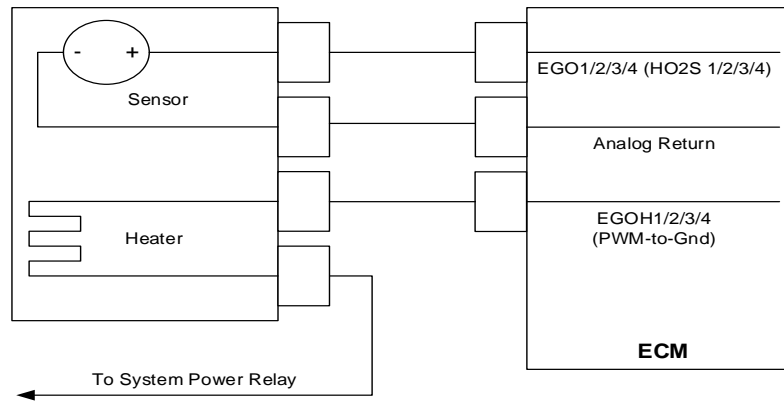

Hardware/Circuit:	Heated or Universal Exhaust Gas Oxygen Sensor (Bank 1-Sensor 1/Bank 1-Before Catalyst) (Bank 2-Sensor 1/Bank 1-Before Catalyst)
--------------------------	---

Hardware/Circuit Description:	<p>The HEGO/HO2S sensor is a switching-type sensor around stoichiometry that measures the oxygen content present in the exhaust to determine if the fuel flow to the engine is correct. A UEGO sensor measures the exhaust content across a wide-range of air-fuel ratios with a linear output proportional to lambda/equivalence ratio/air-fuel ratio. In either case, if there is a deviation between the expected reading and the actual reading, fuel flow is precisely adjusted for each bank using the Closed Loop multiplier and then “learned” with the Adaptive multiplier. The multipliers only update when the system is in either “CL Active” or “CL + Adapt” control modes.</p> <p>The purpose of the Adaptive Learn fuel multiplier is to adjust fuel flow due to variations in fuel composition, engine wear, engine-to-engine build variances, and component degradation.</p>
--------------------------------------	---

Possible Causes:	<p>This fault sets if the Adaptive multiplier exceeds the low limit of normal operation indicating that the engine is operating rich (excess fuel) and requires less fuel than allowed by corrections. Often high negative fueling corrections are a function of one or more of the following conditions: 1) high fuel supply pressure to the fuel injection system, 2) a non-responsive HEGO/UEGO sensor, and/or 3) an injector that is stuck open.</p>
-------------------------	--

DTC 172: Diagnostic Aid

Diagnostic Aids

NOTE: If any other DTCs are present, diagnose those first.

- Oxygen Sensor Wire - Sensor may be mis-positioned contacting the exhaust. Check for short to ground between harness and sensor and on sensor harness
- Injectors - System will be rich if an injector driver or driver circuit fails shorted-to-ground. The system will also be rich if an injector fails in an open.
- Fuel Pressure - System will be rich if fuel pressure is too high. Check fuel pressure in the fuel rail during key-on, engine off and during normal operating conditions.
- System Grounding - ECM and engine must be grounded to the battery with very little resistance allowing for proper current flow. Faulty grounds can cause current supply issues resulting in many undesired problems.

If all tests are OK, replace the HO2S sensor with a known good part and retest.

Code			Fault Description
DTC	SPN	FMI	
174	4239	0	AL high gasoline bank2

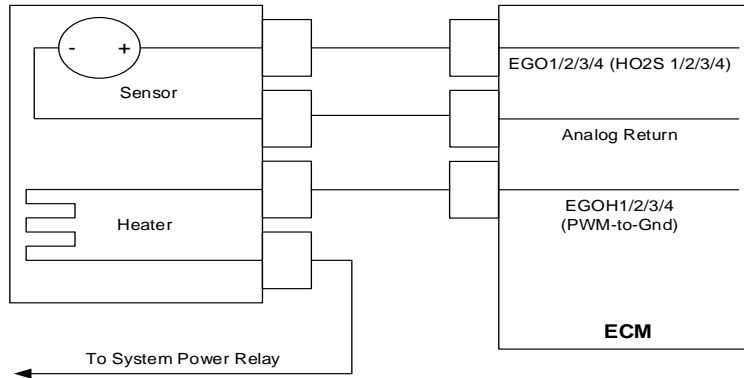

Hardware/Circuit:	Heated or Universal Exhaust Gas Oxygen Sensor (Bank 1-Sensor 1/Bank 1-Before Catalyst) (Bank 2-Sensor 1/Bank 1-Before Catalyst)
--------------------------	---

Hardware/Circuit Description:	<p>The HEGO/HO2S sensor is a switching-type sensor around stoichiometry that measures the oxygen content present in the exhaust to determine if the fuel flow to the engine is correct. A UEGO sensor measures the exhaust content across a wide-range of air-fuel ratios with a linear output proportional to lambda/equivalence ratio/air-fuel ratio. In either case, if there is a deviation between the expected reading and the actual reading, fuel flow is precisely adjusted for each bank using the Closed Loop multiplier and then “learned” with the Adaptive multiplier. The multipliers only update when the system is in either “CL Active” or “CL + Adapt” control modes.</p> <p>The purpose of the Adaptive Learn fuel multiplier is to adjust fuel flow due to variations in fuel composition, engine wear, engine-to-engine build variances, and component degradation.</p>
--------------------------------------	---

Possible Causes:	<p>This fault sets if the Adaptive multiplier exceeds the high limit of normal operation indicating that the engine is operating lean (excess oxygen) and requires more fuel than allowed by corrections. Often high positive fueling corrections are a function of one or more of the following conditions: 1) exhaust leaks upstream or near the HEGO sensor, 2) reduced fuel supply pressure to the fuel injection system, 3) a non-responsive HEGO/UEGO sensor, and/or 3) an injector that is stuck closed.</p>
-------------------------	---

DTC 174: Diagnostic Aid

NOTE: If any other DTCs are present, diagnose those first.

- Oxygen Sensor Wire - Sensor may be mis-positioned contacting the exhaust. Check for short to ground between harness and sensor and on sensor harness.
- Vacuum Leaks - Large vacuum leaks and crankcase leaks can cause a lean exhaust condition at light load.
- Injectors - System will be lean if an injector driver or driver circuit fails. The system will also be lean if an injector fails in a closed manner or is dirty.
- Fuel Pressure - System will be lean if fuel pressure is too low. Check fuel pressure in the fuel rail during key-on, engine off and during normal operating conditions.
- Air in Fuel - If the fuel return hose/line is too close to the fuel supply pickup in the fuel tank, air may become entrapped in the pump or supply line causing a lean condition and driveability problems.
- Exhaust Leaks - If there is an exhaust leak, outside air can be pulled into the exhaust and past the O2 sensor causing a false lean condition.
- Fuel Quality - A drastic variation in fuel quality may cause the system to be lean including oxygenated fuels.
- System Grounding - ECM and engine must be grounded to the battery with very little resistance allowing for proper current flow. Faulty grounds can cause current supply issues resulting in many undesired problems.

If all tests are OK, replace the HO2S sensor with a known good part and retest.

Code			Fault Description
DTC	SPN	FMI	
175	4239	1	AL low gasoline bank2

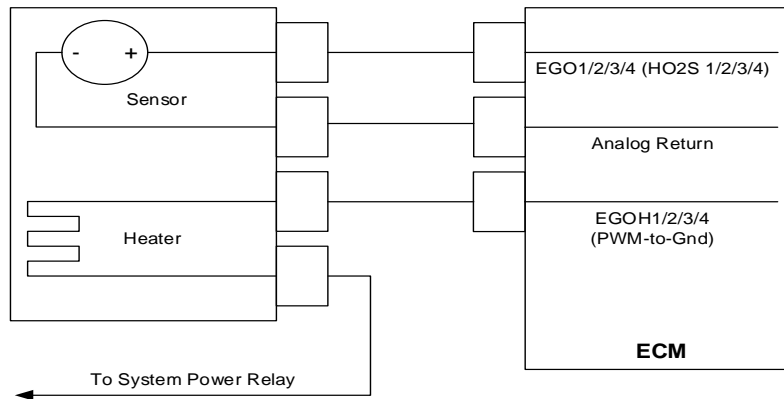

Hardware/Circuit:	Heated or Universal Exhaust Gas Oxygen Sensor (Bank 1-Sensor 1/Bank 1-Before Catalyst) (Bank 2-Sensor 1/Bank 1-Before Catalyst)
--------------------------	---

Hardware/Circuit Description:	<p>The HEGO/HO2S sensor is a switching-type sensor around stoichiometry that measures the oxygen content present in the exhaust to determine if the fuel flow to the engine is correct. A UEGO sensor measures the exhaust content across a wide-range of air-fuel ratios with a linear output proportional to lambda/equivalence ratio/air-fuel ratio. In either case, if there is a deviation between the expected reading and the actual reading, fuel flow is precisely adjusted for each bank using the Closed Loop multiplier and then "learned" with the Adaptive multiplier. The multipliers only update when the system is in either "CL Active" or "CL + Adapt" control modes.</p> <p>The purpose of the Adaptive Learn fuel multiplier is to adjust fuel flow due to variations in fuel composition, engine wear, engine-to-engine build variances, and component degradation.</p>
--------------------------------------	---

Possible Causes:	<p>This fault sets if the Adaptive multiplier exceeds the low limit of normal operation indicating that the engine is operating rich (excess fuel) and requires less fuel than allowed by corrections. Often high negative fueling corrections are a function of one or more of the following conditions: 1) high fuel supply pressure to the fuel injection system, 2) a non-responsive HEGO/UEGO sensor, and/or 3) an injector that is stuck open.</p>
-------------------------	--

DTC 175: Diagnostic Aid

Diagnostic Aids

NOTE: If any other DTCs are present, diagnose those first.

- Oxygen Sensor Wire - Sensor may be mis-positioned contacting the exhaust. Check for short to ground between harness and sensor and on sensor harness
- Injectors - System will be rich if an injector driver or driver circuit fails shorted-to-ground. The system will also be rich if an injector fails in an open.
- Fuel Pressure - System will be rich if fuel pressure is too high. Check fuel pressure in the fuel rail during key-on, engine off and during normal operating conditions.
- System Grounding - ECM and engine must be grounded to the battery with very little resistance allowing for proper current flow. Faulty grounds can cause current supply issues resulting in many undesired problems.

If all tests are OK, replace the HO2S sensor with a known good part and retest.

Code			Fault Description
DTC	SPN	FMI	
182	174	4	FT Gasoline Low Voltage

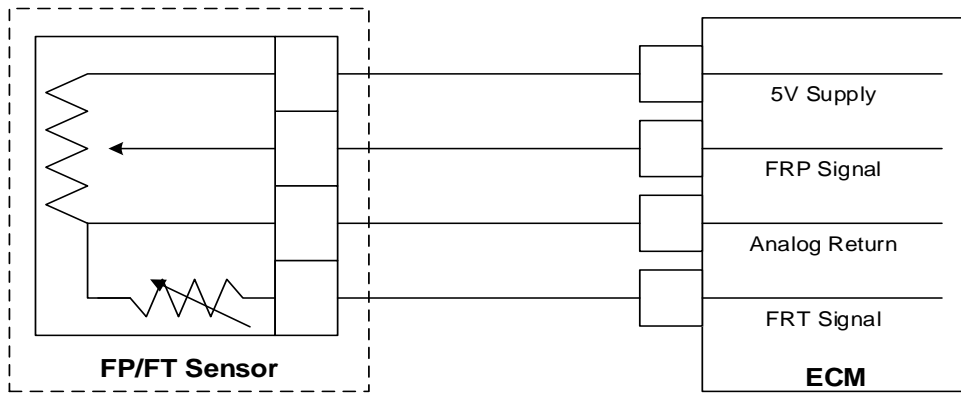

Hardware/Circuit:	Liquid Fuel Temperature Sensor (located in fuel block)
--------------------------	--

Hardware/Circuit Description:	The Fuel Temperature sensor is a thermistor (temperature sensitive resistor) integrated into the fuel pressure TMAP located in the fuel supply line between the fuel pump and the fuel rail. It is used to monitor the fuel temperature exiting the fuel pump to set a fault if the fuel temperature is too high resulting in increased fuel vapor from the fuel tank causing excessive evaporative emissions. The ECM provides a voltage divider circuit so that when the fuel is cool, the signal reads higher voltage, and lower when warm.
--------------------------------------	--

Possible Causes:	This fault will set if the signal voltage is less than the low voltage limit as defined in the diagnostic calibration anytime that the engine is running. The limit is generally set to the voltage that corresponds to the fuel boiling temperature.
-------------------------	---

DTC 182: Troubleshooting Tree

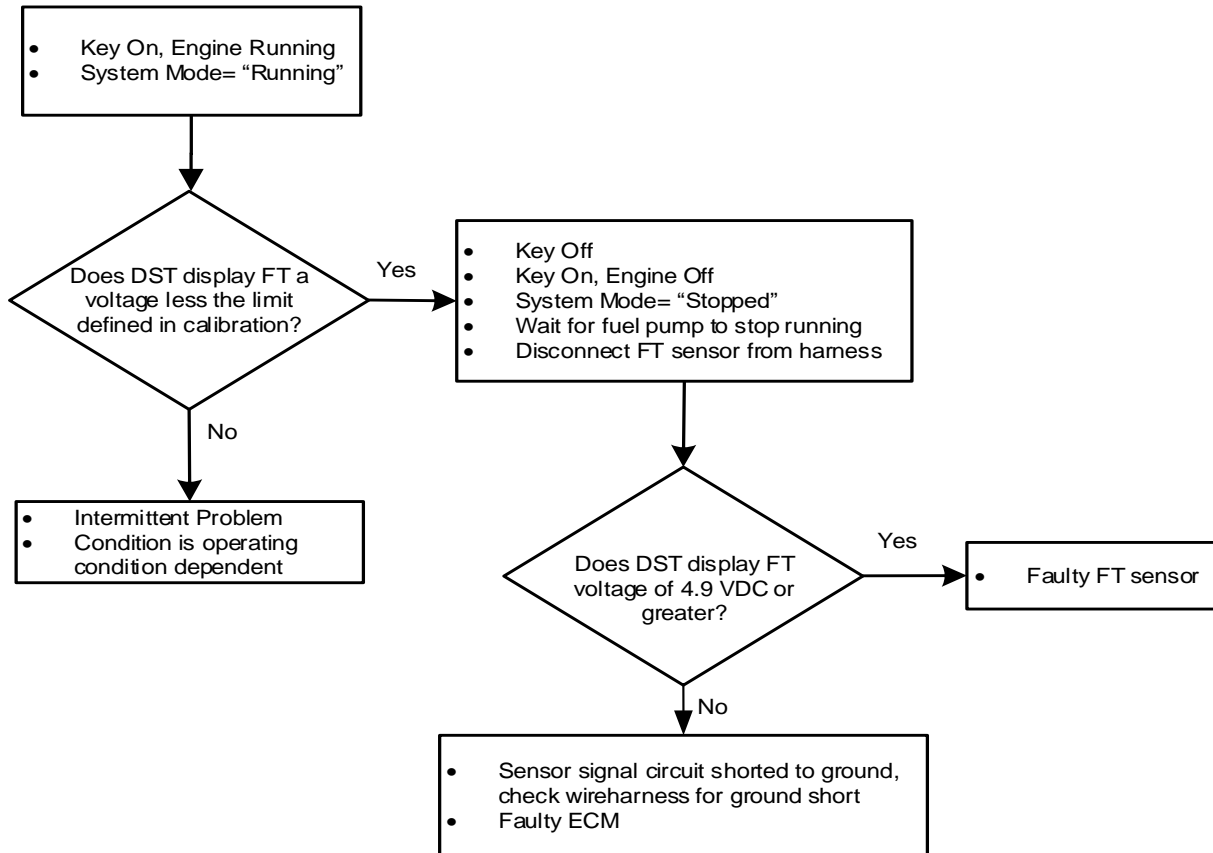

Code			Fault Description
DTC	SPN	FMI	
183	174	3	FT Gasoline High Voltage

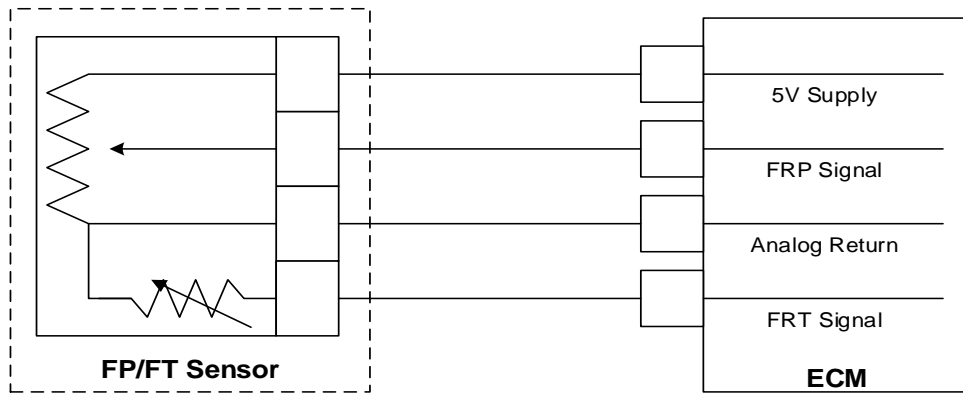

Hardware/Circuit:	Liquid Fuel Temperature Sensor (located in fuel block)
--------------------------	--

Hardware/Circuit Description:	The Fuel Temperature sensor is a thermistor (temperature sensitive resistor) integrated into the fuel pressure TMAP located in the fuel supply line between the fuel pump and the fuel rail. It is used to monitor the fuel temperature exiting the fuel pump to set a fault if the fuel temperature is too high resulting in increased fuel vapor from the fuel tank causing excessive evaporative emissions. The ECM provides a voltage divider circuit so that when the fuel is cool, the signal reads higher voltage, and lower when warm.
--------------------------------------	--

Possible Causes:	This fault will set if the signal voltage is greater than the high voltage limit as defined in the diagnostic calibration anytime that the engine is running. The limit is generally set to 4.9 VDC. During this active fault the MIL and/or secondary warning device should be activated.
-------------------------	--

DTC 183: Troubleshooting Tree

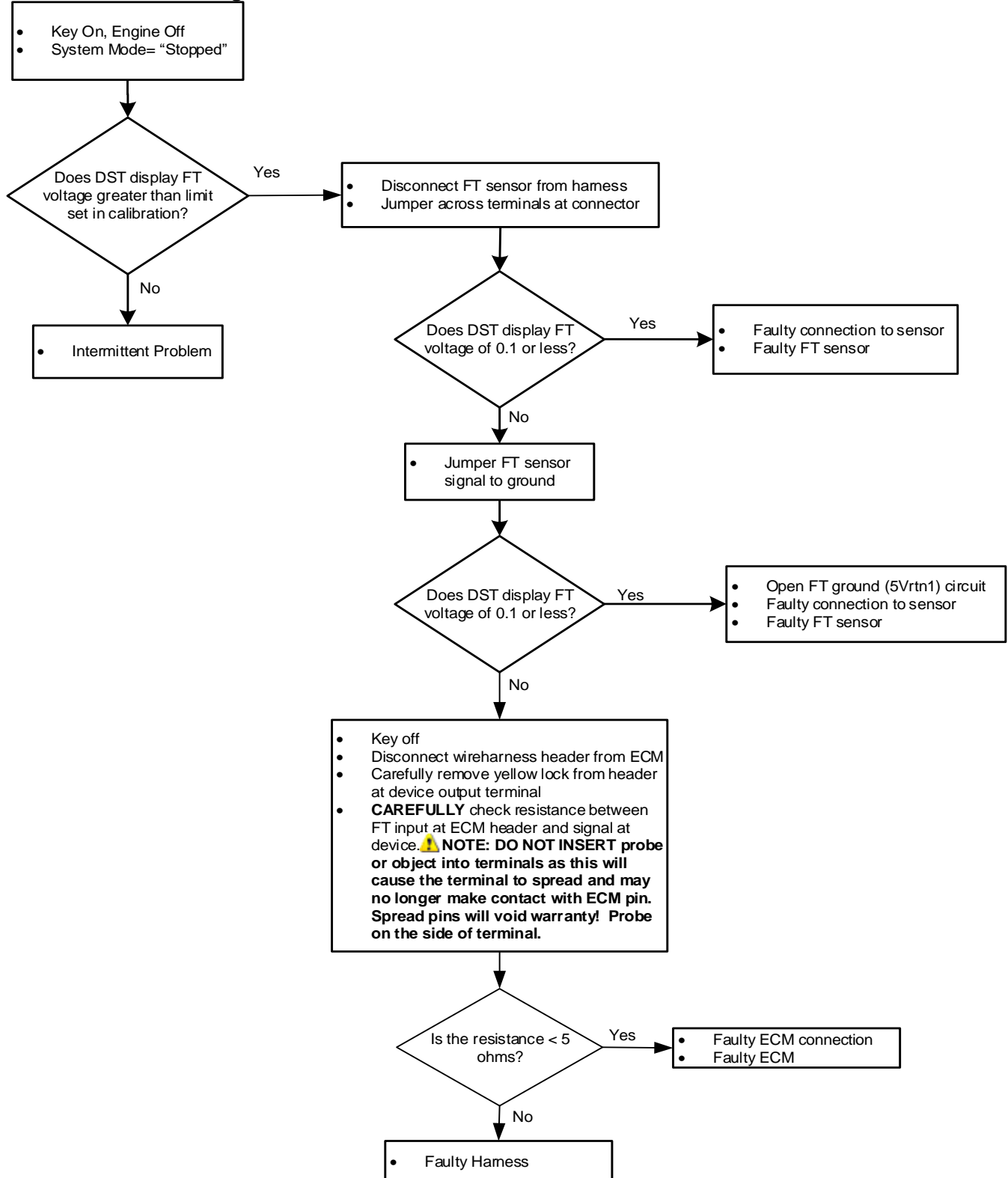

Code			Fault Description
DTC	SPN	FMI	
187	3468	4	FT Gaseous fuel low voltage

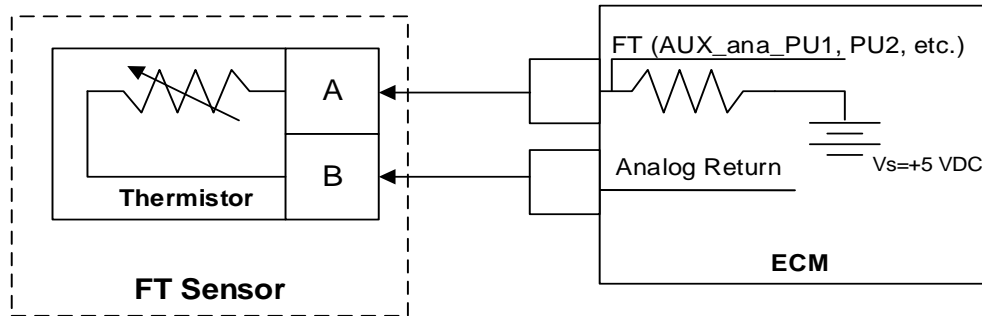

Hardware/Circuit:	Gaseous Fuel Temperature Sensor (Located in fuel block)
--------------------------	---

Hardware/Circuit Description:	The Fuel Temperature sensor is a thermistor (temperature sensitive resistor) integrated into the EPR fuel outlet. It is used to monitor the gaseous fuel temperature exiting the EPR to be used as an input in a fuel temperature estimation of the temperature entering the gaseous mixer. This information is used to calculate a real-time fuel pressure correction in order to reduce fueling errors. The ECM provides a voltage divider circuit so that when the fuel is cool, the signal reads higher voltage, and lower when warm.
--------------------------------------	---

Possible Causes:	This fault is not user-modifiable. It is always enabled and is intended to protect the CFV from extremely low fuel temperatures by load limiting the system when the FT falls below the target temperature given in the fault conditions. Typically when fuel temp < -40 deg F.
-------------------------	---

Code			Fault Description
DTC	SPN	FMI	
188	3468	3	FT Gaseous fuel high voltage

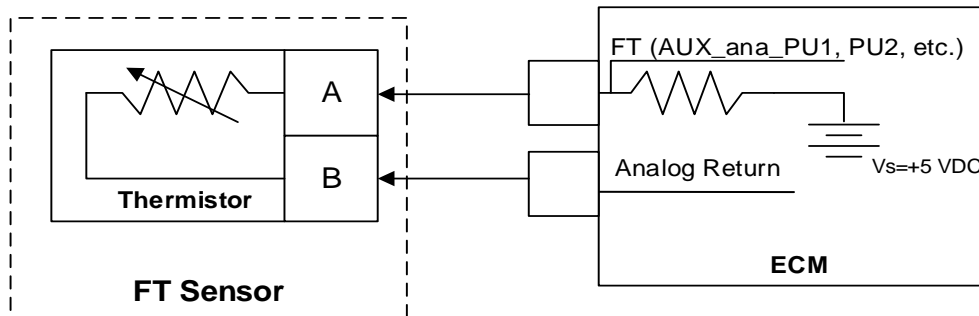

Hardware/Circuit:	Gaseous Fuel Temperature Sensor (Located in fuel block)
--------------------------	---

Hardware/Circuit Description:	The Fuel Temperature sensor is a thermistor (temperature sensitive resistor) integrated into the EPR fuel outlet. It is used to monitor the gaseous fuel temperature exiting the EPR to be used as an input in a fuel temperature estimation of the temperature entering the gaseous mixer. This information is used to calculate a real-time fuel pressure correction in order to reduce fueling errors. The ECM provides a voltage divider circuit so that when the fuel is cool, the signal reads higher voltage, and lower when warm.
--------------------------------------	---

Possible Causes:	This fault will set if the signal voltage is greater than the high voltage limit as defined in the diagnostic calibration anytime that the engine is running. The limit is generally set to 4.90 VDC.
-------------------------	---

DTC 188: Troubleshooting Tree

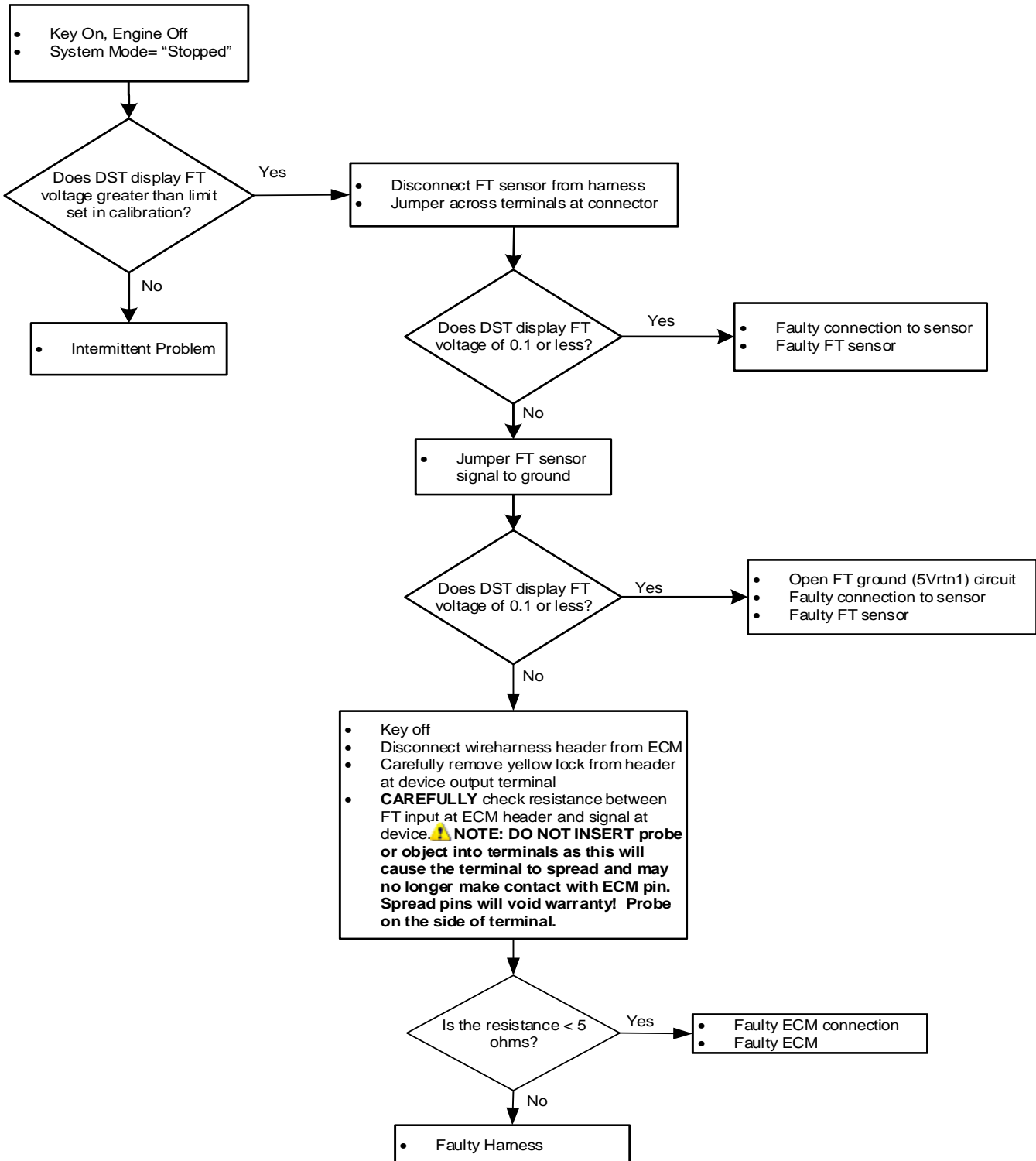

Code			Fault Description
DTC	SPN	FMI	
217	110	0	ECT Higher than Expected 2

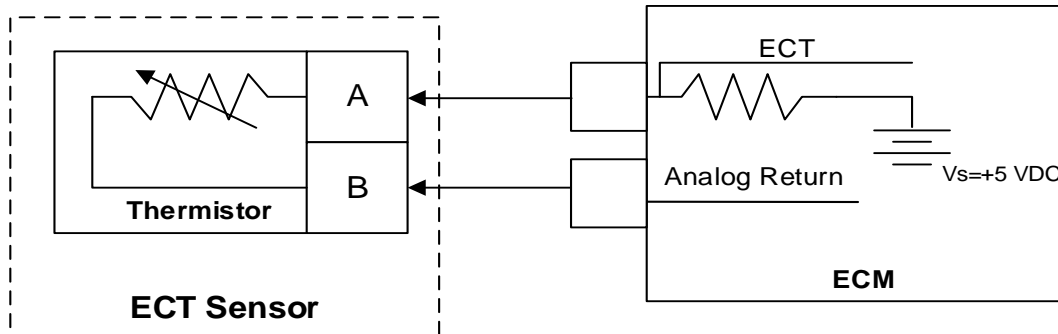

Hardware/Circuit:	Engine Coolant Temperature Sensor
--------------------------	-----------------------------------

Hardware/Circuit Description:	<p>The Engine Coolant Temperature sensor is a thermistor (temperature sensitive resistor) located in the engine coolant. Some engines use a CHT sensor that is located in the coolant in the cylinder head. Some engines use an ECT (Engine Coolant Temperature) sensor that is located in the coolant near the thermostat. If the engine is equipped with a CHT sensor then the ECT value is estimated. If equipped with an ECT sensor then the CHT value is estimated. They are used for engine airflow calculation, ignition timing control, to enable certain features, and for engine protection.</p> <p>The ECM provides a voltage divider circuit so when the sensor reading is cool the sensor reads higher voltage, and lower when warm.</p>
--------------------------------------	---

Possible Causes:	<p>This fault will help protect the engine in the event of over temperature. When the coolant exceeds x deg. F and engine RPM exceeds y RPM for the latch time this fault will set.</p>
-------------------------	---

DTC 217: Diagnostic Aid

Diagnostic Aids

- If the “ECT High Voltage” fault is also present, follow the troubleshooting procedures for that fault as it may have caused “ECT Higher Than Expected 2.”
- If the cooling system utilizes an air-to-water heat exchanger (radiator) and fan:
 - Check that the radiator has a proper amount of ethylene glycol/water and that the radiator is not leaking.
 - Ensure that there is no trapped air in the cooling path.
 - Inspect the cooling system (radiator and hoses) for cracks and ensure connections are leak free.
 - Check that the fan is operating properly.
 - Check that the thermostat is not stuck closed.
- If the cooling system utilizes a water-to-water heat exchanger:
 - Check that the heat exchanger has a proper amount of ethylene glycol/water and that the heat exchanger is not leaking.
 - Ensure that there is no trapped air in the cooling path.
 - Inspect the cooling system (radiator and hoses) for cracks and ensure connections are leak free.
 - Check that the raw water pickup is not blocked/restricted by debris and that the hose is tightly connected.
 - Check that the thermostat is not stuck closed.

Check that the raw water pump/impeller is tact and that it is not restricted.

Code			Fault Description
DTC	SPN	FMI	
219	515	15	Max Govern Speed Override

Hardware/Circuit:	Max Govern Speed Override
--------------------------	---------------------------

Hardware/Circuit Description:	The Max Allowed Governed Speed overrides any higher max governor speeds programmed by the user. This fault is designed to help prevent engine or equipment damage.
--------------------------------------	--

Possible Causes:	This fault will set anytime the engine RPM exceeds the limit set in the diagnostic calibration for the latch time or more.
-------------------------	--

Diagnostic Aids

NOTE: If any other DTCs are present, diagnose those first.

- Ensure that no programmed governor speeds exceed the limit set in the diagnostic calibration for Max Gov Override Speed
- Check mechanical operation of the throttle

Check the engine intake for large air leaks downstream of the throttle body

Code			Fault Description
DTC	SPN	FMI	
221	51	0	TPS1 Higher than TPS2

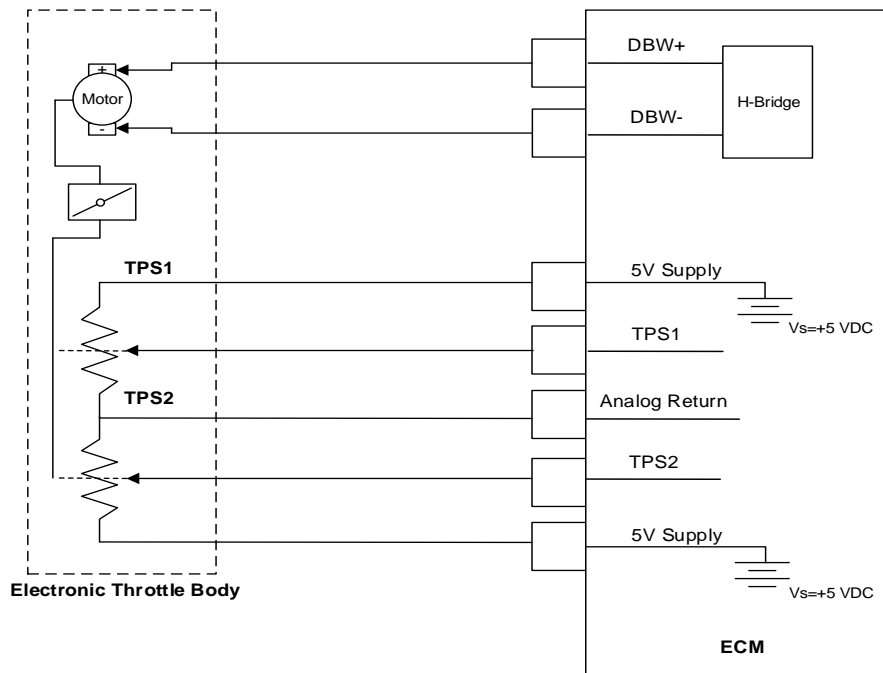

Hardware/Circuit:	Throttle Body-Throttle Position Sensor 1 & 2 (electronic throttle body only)
--------------------------	--

Hardware/Circuit Description:	<p>The throttle controls the airflow through the engine, directly affecting the power output of the engine. When the throttle is electronically controlled in an Electronic Throttle Body it can be used to control the idle stability and limit engine speed based on operating conditions.</p> <p>The Throttle Position Sensor uses either 1) a variable resistor and voltage divider circuit or 2) a non-contact hall-effect sensor to determine throttle plate position, and is located within the throttle body. The output of the TPS is linear with angular position. The TPS input(s) provide angular position feedback of the throttle plate. In an Electronic Throttle Body multiple position feedback sensors (usually two counteracting potentiometers/hall-effects) are used to perform speed governing with improved safety and redundancy.</p>
--------------------------------------	---

Possible Causes:	<p>This fault will set if TPS1 % is higher than TPS2 % by the amount defined in the diagnostic calibration. At this point the throttle is considered to be out of specification, or there is a problem with the TPS signal circuit. During this active fault, an audible/visual alert device is activated and either an engine shutdown should be triggered or throttle control is set to use the higher of the two feedback signals for control in combination with a low rev limit and/or power derate.</p>
-------------------------	---

DTC 221: Troubleshooting Tree

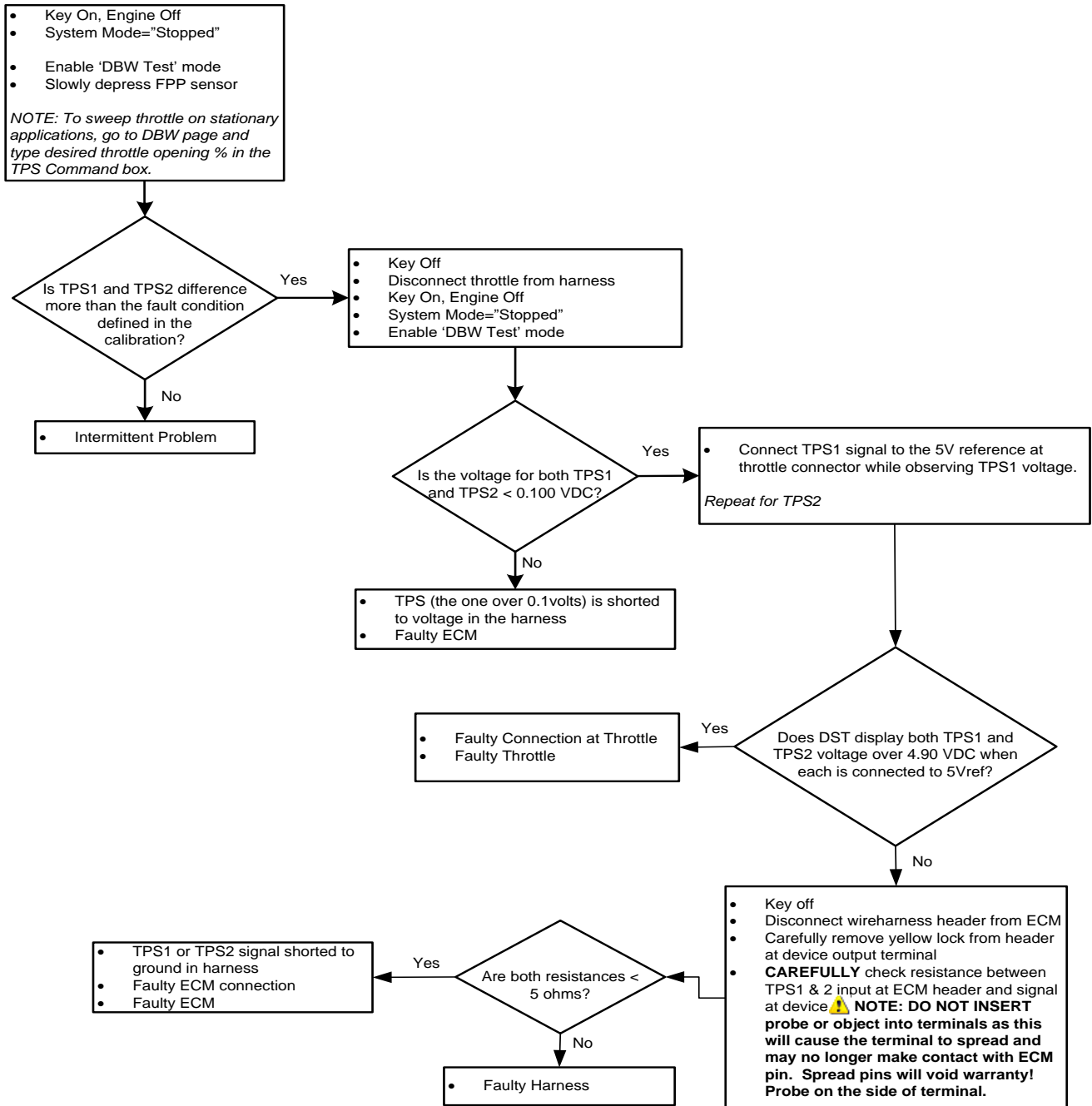

Code			Fault Description
DTC	SPN	FMI	
222	3673	4	TPS2 Signal Voltage Low

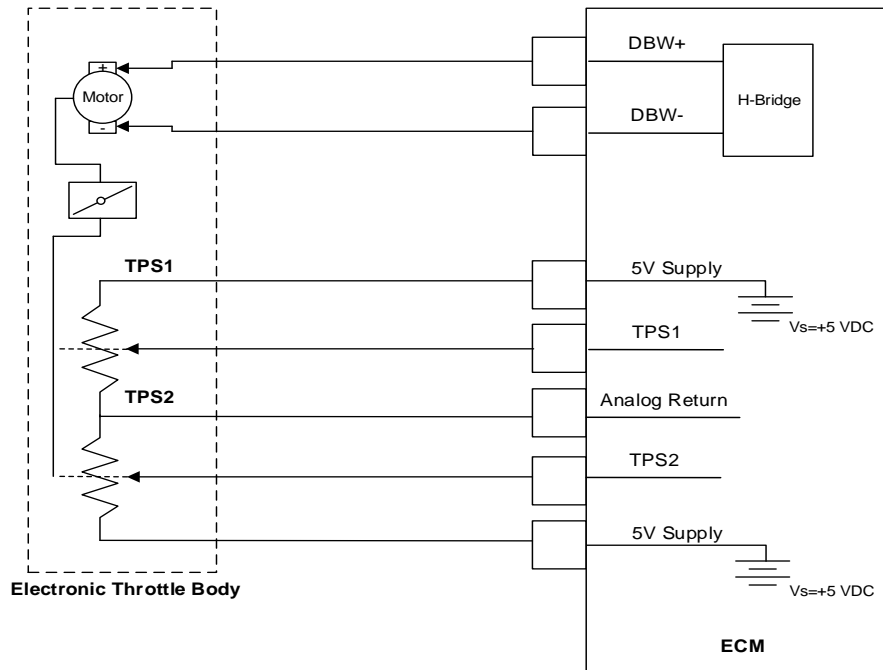

Hardware/Circuit:	Throttle Body-Throttle Position Sensor 1 & 2 (electronic throttle body only)
--------------------------	--

Hardware/Circuit Description:	<p>The throttle controls the airflow through the engine, directly affecting the power output of the engine. When the throttle is electronically controlled in an Electronic Throttle Body it can be used to control the idle stability and limit engine speed based on operating conditions.</p> <p>The Throttle Position Sensor uses either 1) a variable resistor and voltage divider circuit or 2) a non-contact hall-effect sensor to determine throttle plate position, and is located within the throttle body. The output of the TPS is linear with angular position. The TPS input(s) provide angular position feedback of the throttle plate. In an Electronic Throttle Body multiple position feedback sensors (usually two counteracting potentiometers/hall-effects) are used to perform speed governing with improved safety and redundancy.</p>
--------------------------------------	---

Possible Causes:	<p>This fault will set if TPS[N] voltage is lower than the low voltage limit as defined in the diagnostic calibration at any operating condition while the engine is cranking or running. The limit is generally set to 4.90 VDC. In many cases, this condition is caused by the TPS sensor being disconnected from the engine harness, an open-circuit or short-to-ground of the TPS circuit in the wire harness, or a failure of the sensor. This fault should be configured to trigger an engine shutdown and the engine will not start with this fault active.</p>
-------------------------	--

DTC 222: Troubleshooting Tree

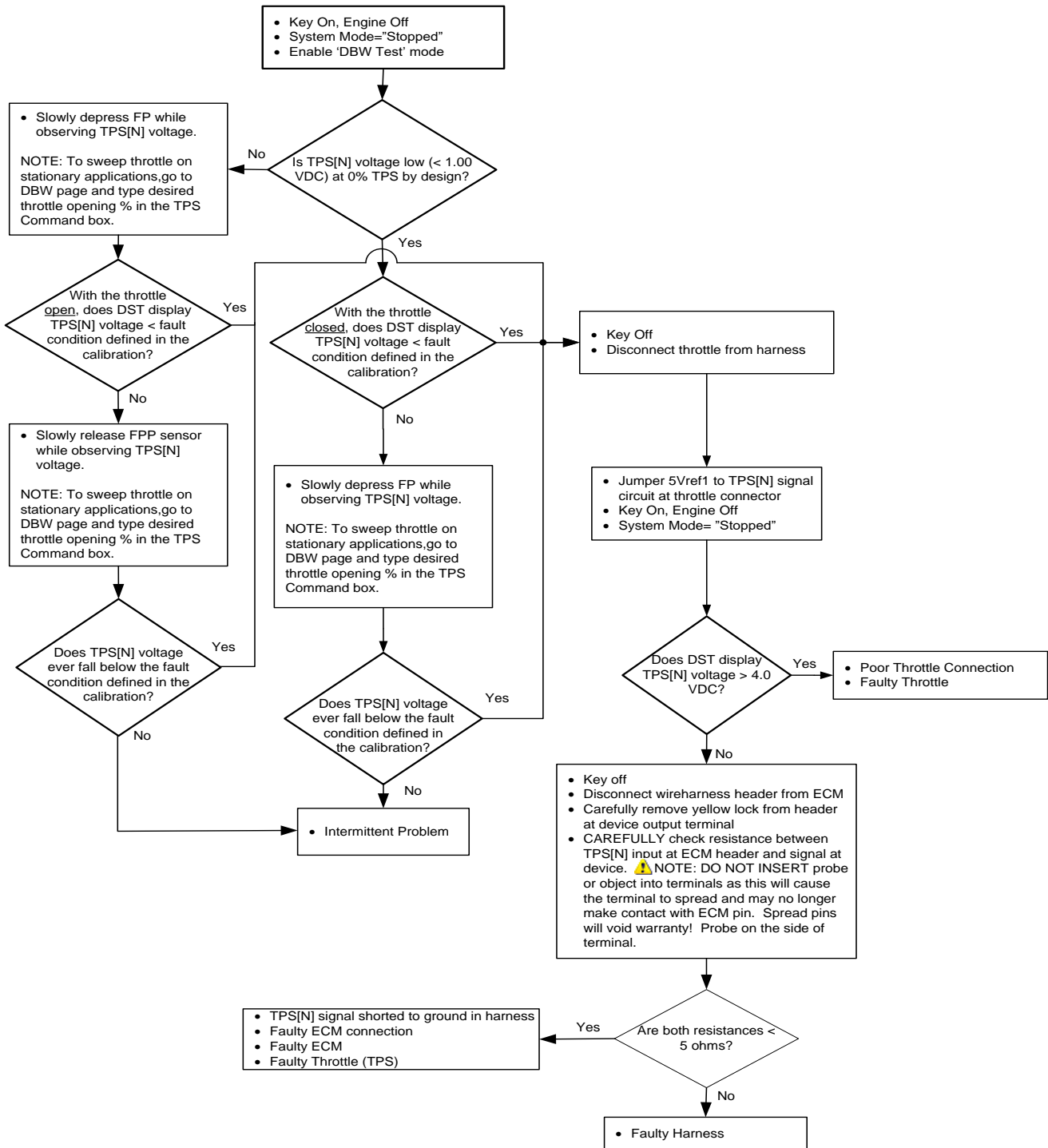

Code			Fault Description
DTC	SPN	FMI	
223	3673	3	TPS2 Signal Voltage High

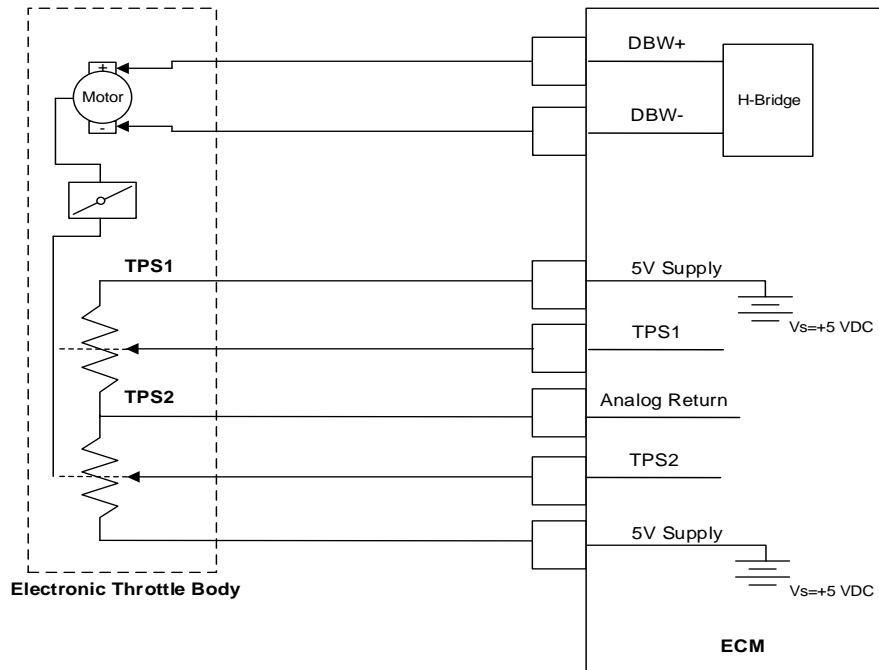

Hardware/Circuit:	Throttle Body-Throttle Position Sensor 1 & 2 (electronic throttle body only)
--------------------------	--

Hardware/Circuit Description:	<p>The throttle controls the airflow through the engine, directly affecting the power output of the engine. When the throttle is electronically controlled in an Electronic Throttle Body it can be used to control the idle stability and limit engine speed based on operating conditions.</p> <p>The Throttle Position Sensor uses either 1) a variable resistor and voltage divider circuit or 2) a non-contact hall-effect sensor to determine throttle plate position, and is located within the throttle body. The output of the TPS is linear with angular position. The TPS input(s) provide angular position feedback of the throttle plate. In an Electronic Throttle Body multiple position feedback sensors (usually two counteracting potentiometers/hall-effects) are used to perform speed governing with improved safety and redundancy.</p>
--------------------------------------	---

Possible Causes:	<p>This fault will set if TPS[N] voltage is higher than the limit set in the diagnostic calibration at any operating condition while the engine is cranking or running. The limit is generally set to 4.90 VDC. In many cases, this condition is caused by a short-to-power of the TPS circuit in the wire harness or a failure of the sensor.</p>
-------------------------	--

DTC 223: Troubleshooting Tree

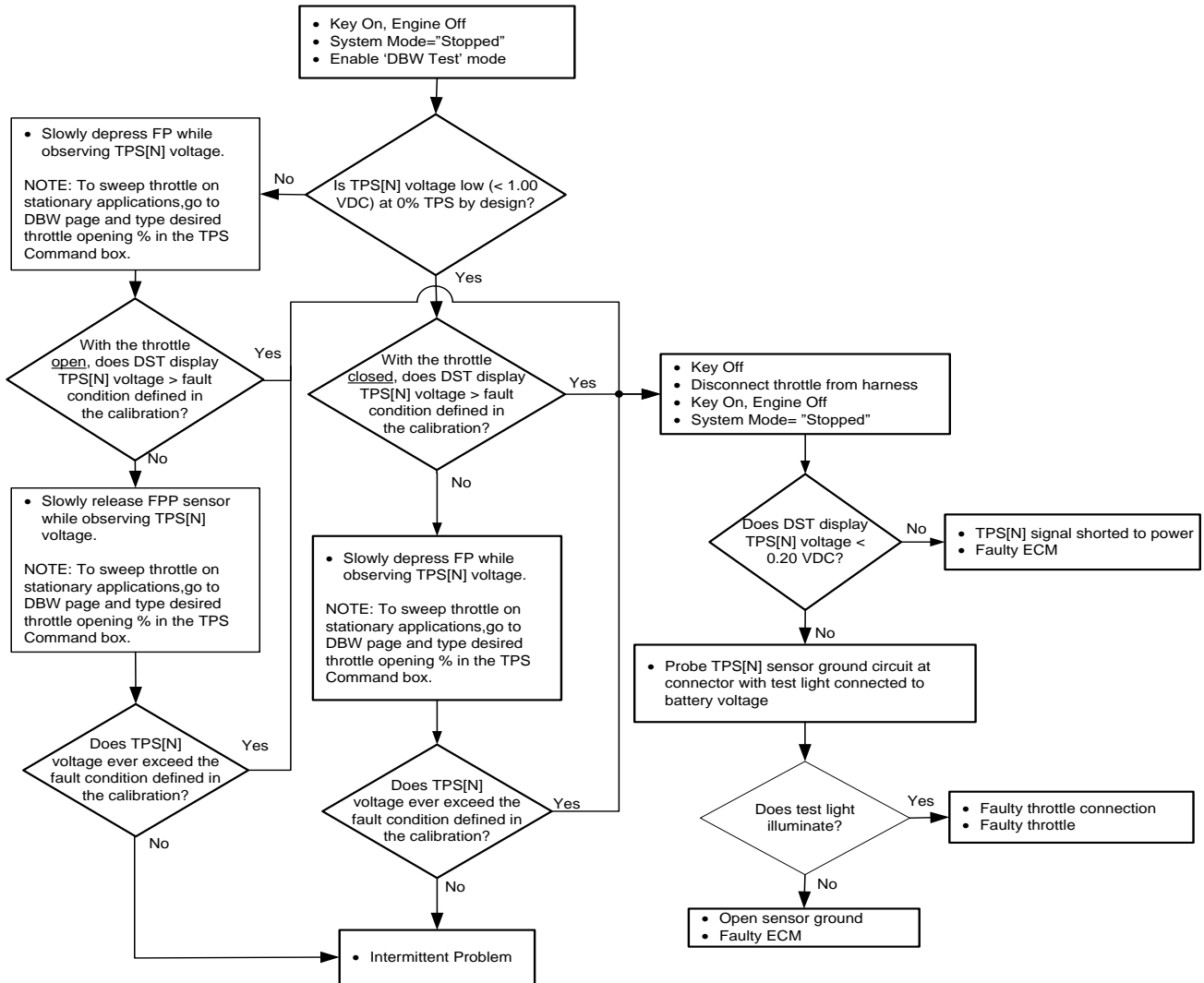

Code			Fault Description
DTC	SPN	FMI	
236	102	2	TIP Active

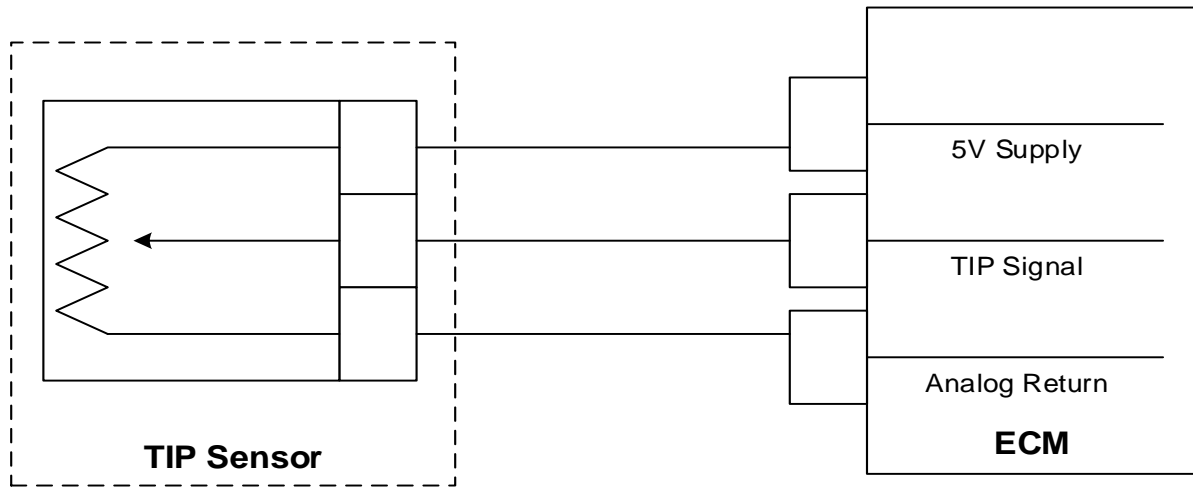

Hardware/Circuit:	Throttle Inlet Pressure (Boost) Sensor
--------------------------	--

Hardware/Circuit Description:	The Throttle Inlet Pressure sensor is a pressure transducer located in the intake air stream between the turbocharger or supercharger and the throttle. It is used to measure the boosted air pressure in the intake air stream prior to the throttle. The pressure reading is used in conjunction with other inputs to determine the rate of airflow to the throttle and is used to for boost bypass control.
--------------------------------------	--

Possible Causes:	This fault detects if the TIP sensor is pneumatically attached to the intake system and whether or not TIP is functional. It sets if MAP is rising without a corresponding change in TIP based on TIP being less than x psia while MAP is greater than y psia as defined in the diagnostic calibration. Recommended corrective action(s) include outputting a warning to the user.
-------------------------	--

DTC 236: Troubleshooting Tree

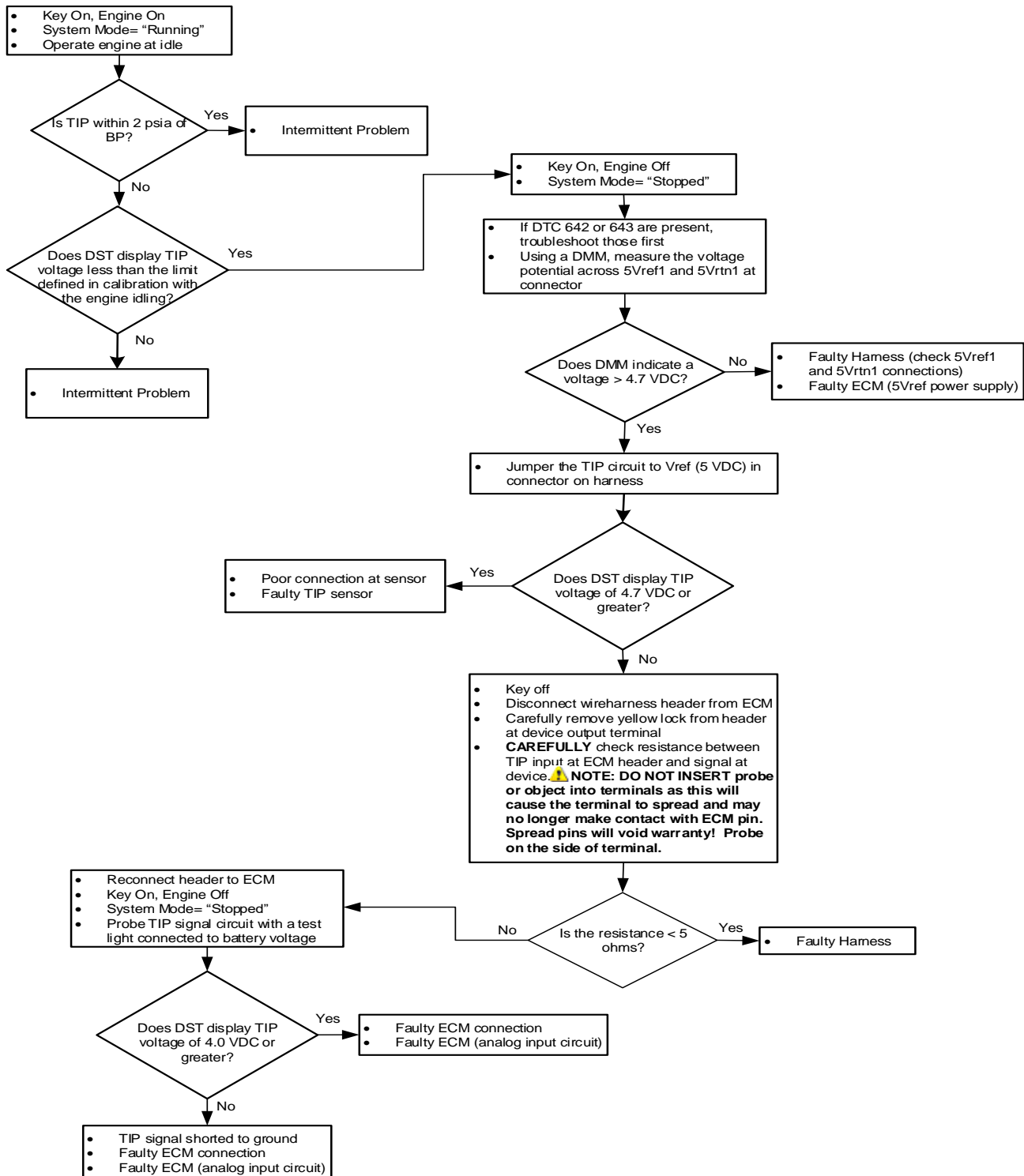

Code			Fault Description
DTC	SPN	FMI	
237	102	4	TIP Low Voltage

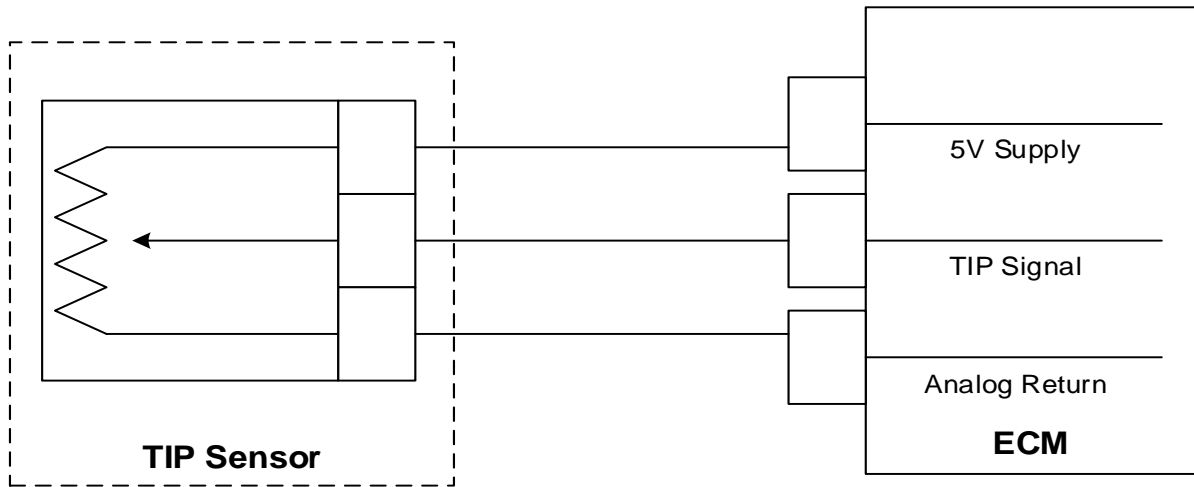

Hardware/Circuit:	Throttle Inlet Pressure (Boost) Sensor
--------------------------	--

Hardware/Circuit Description:	The Throttle Inlet Pressure sensor is a pressure transducer located in the intake air stream between the turbocharger or supercharger and the throttle. It is used to measure the boosted air pressure in the intake air stream prior to the throttle. The pressure reading is used in conjunction with other inputs to determine the rate of airflow to the throttle and is used to for boost bypass control.
--------------------------------------	--

Possible Causes:	This fault will set when the TIP sensor voltage feedback is sensed as lower than the sensor should normally produce as set in the diagnostic calibration. The limit is generally set at 0.10 VDC. In many cases, this condition is caused by the TIP sensor being disconnected from the engine harness, an open-circuit or short-to-ground of the TIP circuit in the wireharness, a loss of sensor reference voltage, or a failure of the sensor. Recommended corrective action(s) include outputting a warning to the user.
-------------------------	--

DTC 237: Troubleshooting Tree

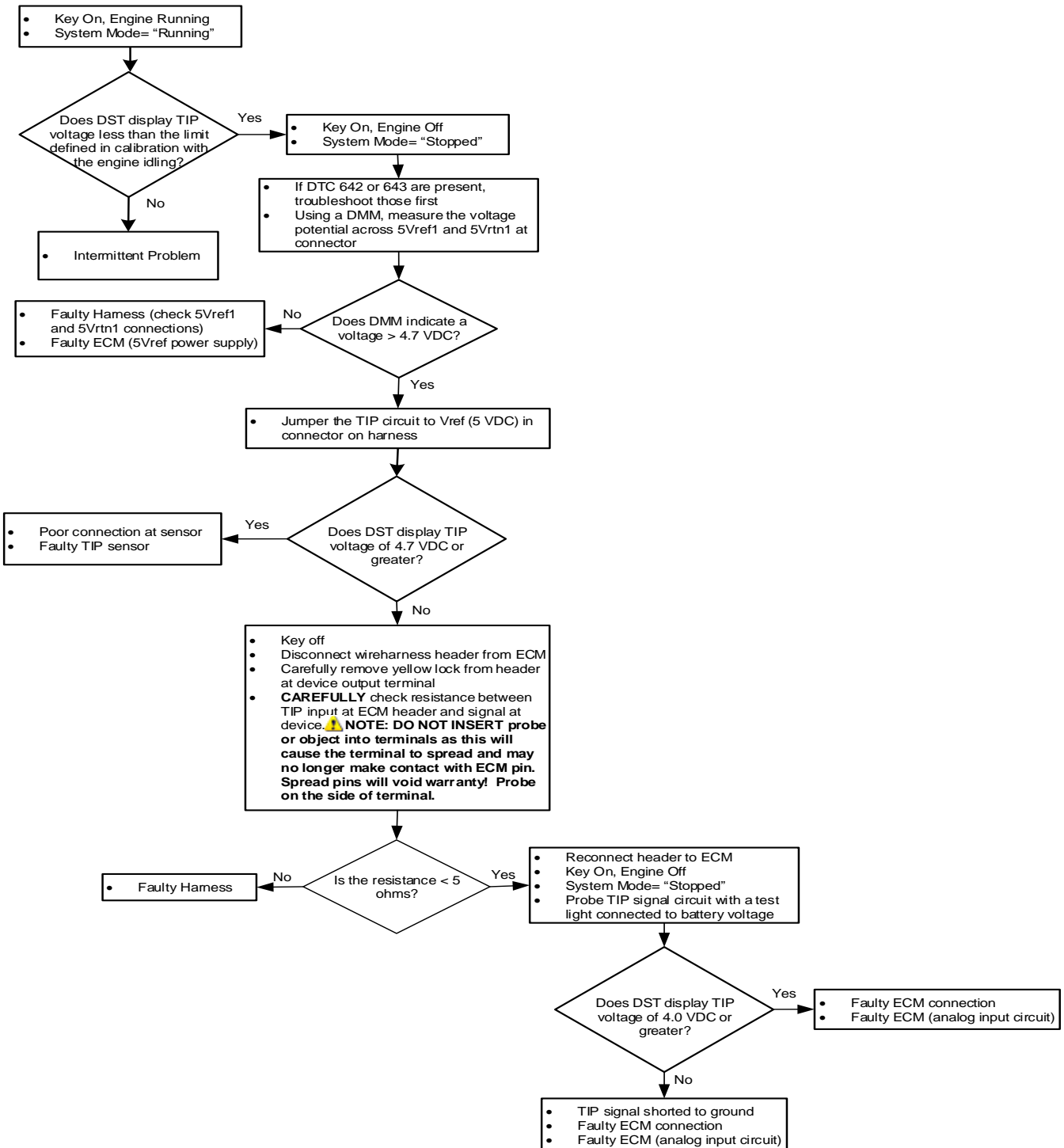

Code			Fault Description
DTC	SPN	FMI	
238	102	3	TIP High Voltage

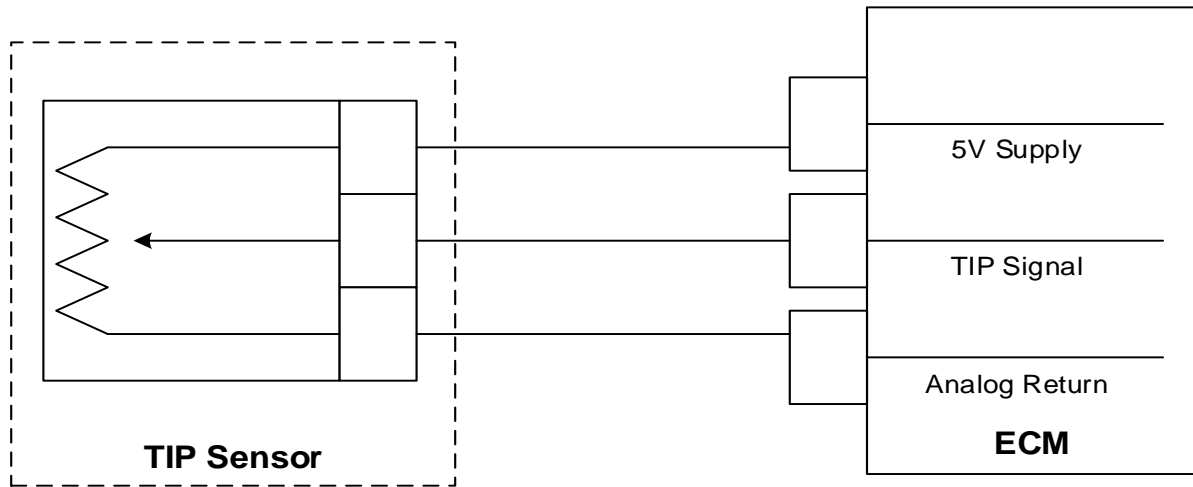

Hardware/Circuit:	Throttle Inlet Pressure (Boost) Sensor
--------------------------	--

Hardware/Circuit Description:	The Throttle Inlet Pressure sensor is a pressure transducer located in the intake air stream between the turbocharger or supercharger and the throttle. It is used to measure the boosted air pressure in the intake air stream prior to the throttle. The pressure reading is used in conjunction with other inputs to determine the rate of airflow to the throttle and is used to for boost bypass control.
--------------------------------------	--

Possible Causes:	This fault will set when the TIP sensor voltage feedback is sensed as higher than the sensor should normally produce while MAP is lower than x psia as set in the diagnostic calibration. Under no circumstances should TIP be lower than MAP. The limit is generally set at 4.80 VDC. In many cases, this condition can be caused by the TIP circuit being shorted to a voltage source or a failure of the sensor. Recommended corrective action(s) include outputting a warning to the user.
-------------------------	--

DTC 238: Troubleshooting Tree

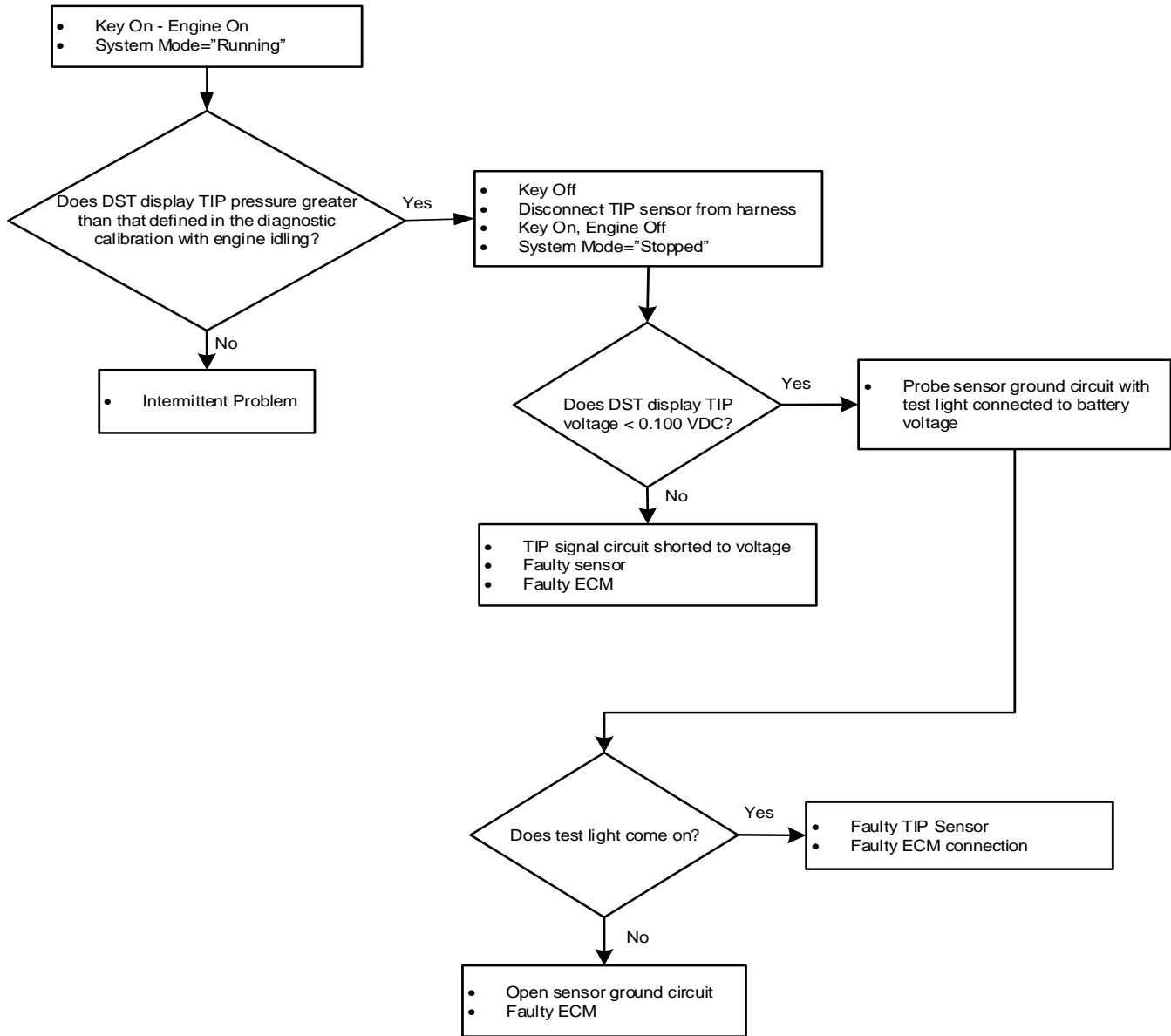

Code			Fault Description
DTC	SPN	FMI	
261	651	5	INJECTOR LOOP OPEN OR LOW-SIDE SHORT TO GROUND (CYLINDER / FIRE Order 1)
264	652	5	INJECTOR LOOP OPEN OR LOW-SIDE SHORT TO GROUND (CYLINDER / FIRE Order 2)
267	653	5	INJECTOR LOOP OPEN OR LOW-SIDE SHORT TO GROUND (CYLINDER / FIRE Order 3)
270	654	5	INJECTOR LOOP OPEN OR LOW-SIDE SHORT TO GROUND (CYLINDER / FIRE Order 4)
273	655	5	INJECTOR LOOP OPEN OR LOW-SIDE SHORT TO GROUND (CYLINDER / FIRE Order 5)
276	656	5	INJECTOR LOOP OPEN OR LOW-SIDE SHORT TO GROUND (CYLINDER / FIRE Order 6)
279	657	5	INJECTOR LOOP OPEN OR LOW-SIDE SHORT TO GROUND (CYLINDER / FIRE Order 7)
282	658	5	INJECTOR LOOP OPEN OR LOW-SIDE SHORT TO GROUND (CYLINDER / FIRE Order 8)
285	659	5	INJECTOR LOOP OPEN OR LOW-SIDE SHORT TO GROUND (CYLINDER / FIRE Order 9)
288	660	5	INJECTOR LOOP OPEN OR LOW-SIDE SHORT TO GROUND (CYLINDER / FIRE Order 10)

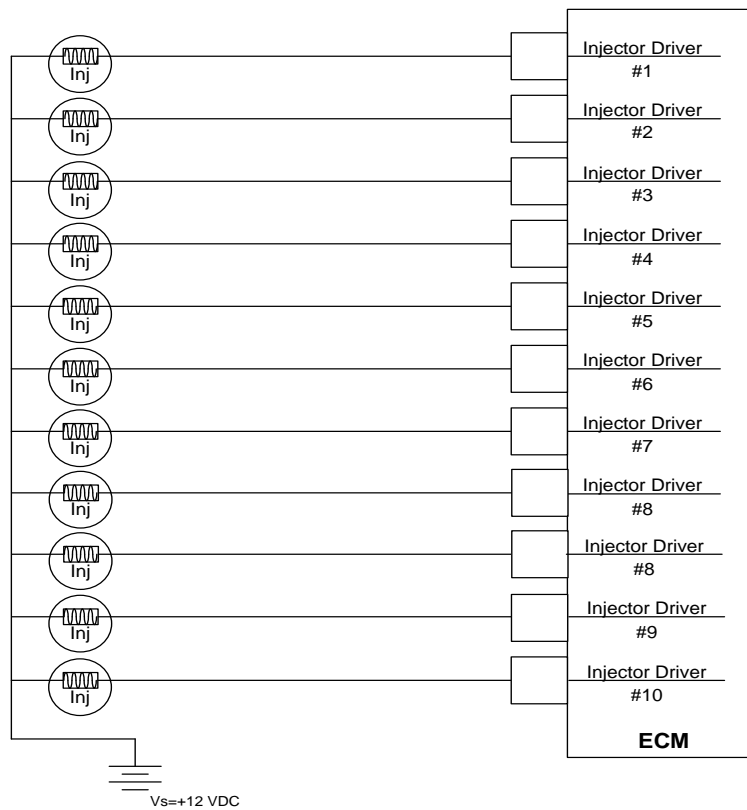

Hardware/Circuit Description:

The fuel injector is an electronically controlled valve and nozzle that is controlled to deliver a precise quantity of fuel to a cylinder (Sequential Port Fuel Injection) or the entire engine (Throttle Body Injection). For a given 'cylinder' number fault enabled, the fault sets for either that number injector in the firing order or for the injector on that numbered cylinder depending on the Firing Order/Block Order configuration of the engine's calibration.

Possible Causes:

This fault will set if the ECM detects low feedback voltage (\underline{y} VDC) on the injector coil while the injector drive circuit is in the off-state and battery voltage is greater than \underline{x} volts for the number of injector firings as defined in the diagnostic calibration.

DTC 261-288: Troubleshooting Tree

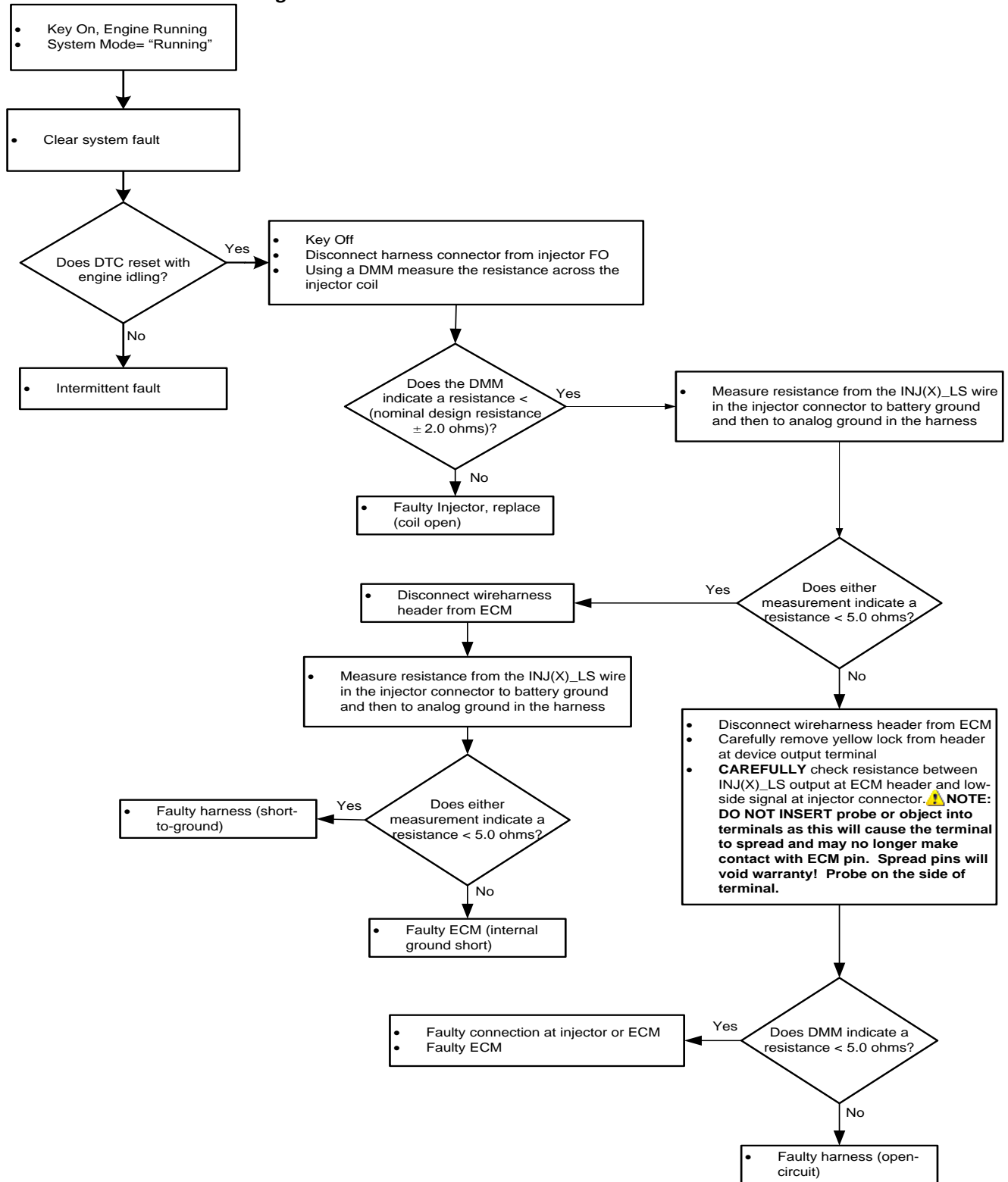

Code			Fault Description
DTC	SPN	FMI	
262	651	3	Injector Coil Shorted Clyinder / Fire Order 1
265	652	3	Injector Coil Shorted Clyinder / Fire Order 2
268	653	3	Injector Coil Shorted Clyinder / Fire Order 3
271	654	3	Injector Coil Shorted Clyinder / Fire Order 4
274	655	3	Injector Coil Shorted Clyinder / Fire Order 5
277	656	3	Injector Coil Shorted Clyinder / Fire Order 6
280	657	3	Injector Coil Shorted Clyinder / Fire Order 7
283	658	3	Injector Coil Shorted Clyinder / Fire Order 8
286	659	6	Injector Coil Shorted Clyinder / Fire Order 9
289	660	6	Injector Coil Shorted Clyinder / Fire Order 10

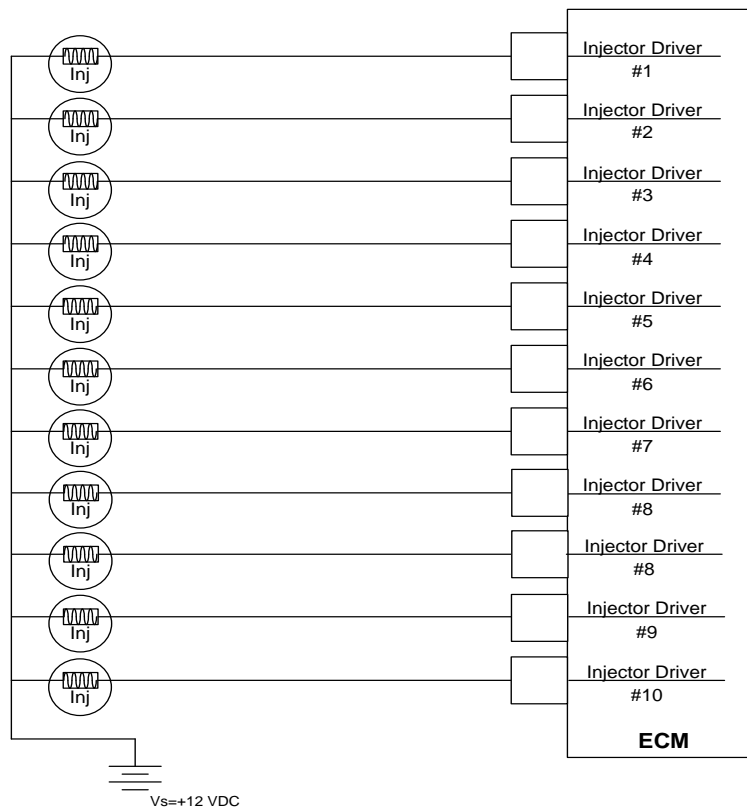

Hardware/Circuit Description:

The fuel injector is an electronically controlled valve and nozzle that is controlled to deliver a precise quantity of fuel to a cylinder (Sequential Port Fuel Injection) or the entire engine (Throttle Body Injection). For a given 'cylinder' number fault enabled, the fault sets for either that number injector in the firing order or for the injector on that numbered cylinder depending on the Firing Order/Block Order configuration of the engine's calibration.

Possible Causes:

This fault will set if the ECM detects low feedback voltage (y VDC) on the injector coil while the injector drive circuit is in the off-state and battery voltage is greater than x volts for the number of injector firings as defined in the diagnostic calibration.

DTC 262-289: Troubleshooting Tree

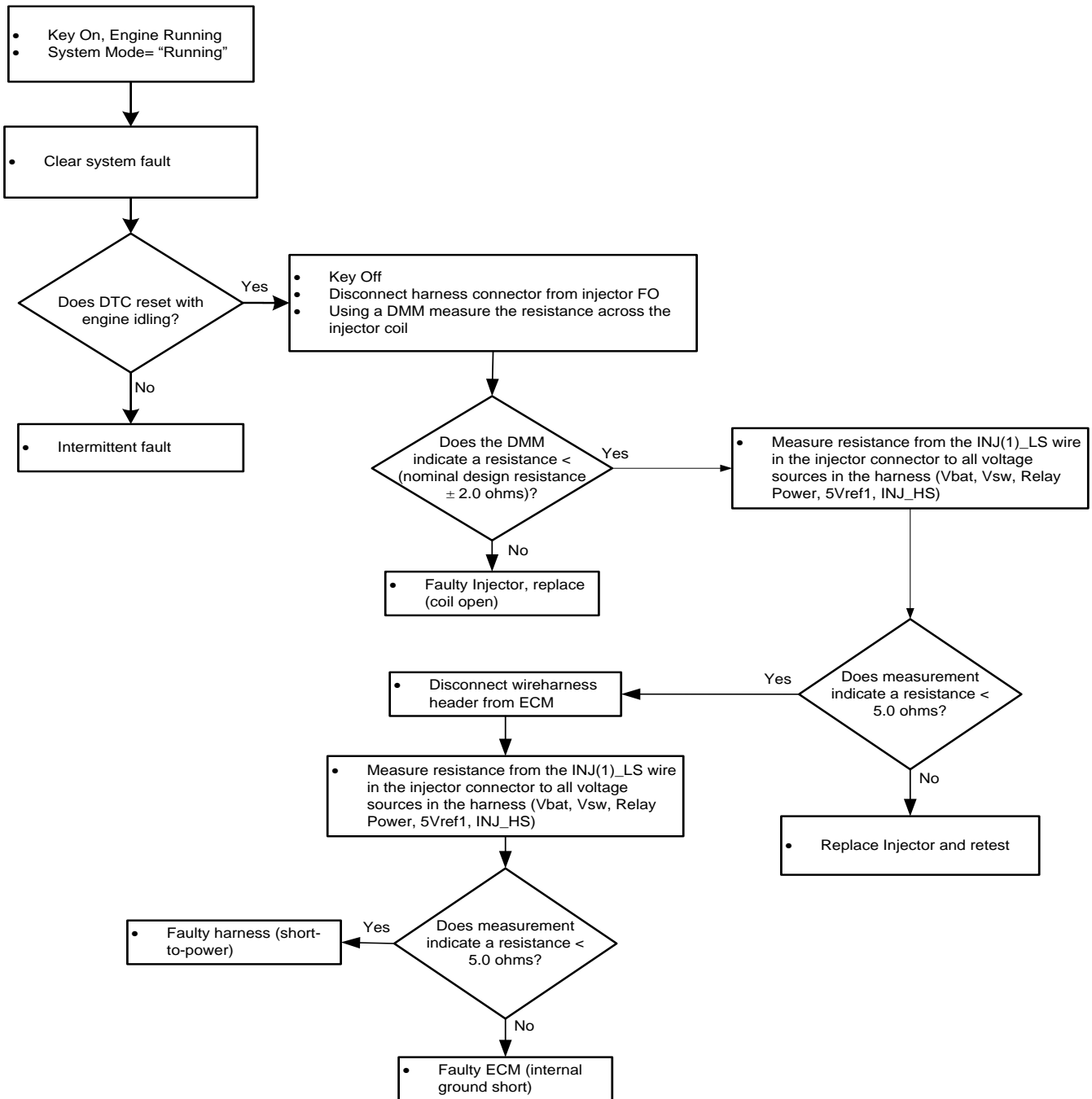

Code			Fault Description
DTC	SPN	FMI	
326	731	2	Knock 1 Excessive Signal
331	520197	2	Knock 2 Excessive Signal

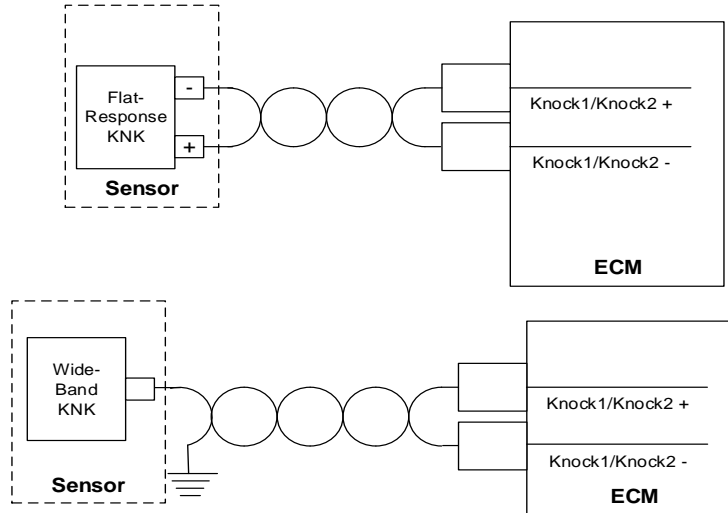

Hardware/Circuit Description:

The knock sensor is used to detect detonation through mechanical vibration in the engine block and/or cylinder heads and provide feedback for the ignition system to retard spark to reduce knock intensity. In most applications the knock sensor is used to protect the engine from damage that can be caused from detonation or knock based on fixed spark advance. In other applications, the knock sensor is used to optimize spark advance and “learn” between spark tables based on fuel quality.

Possible Causes:

This fault sets if the signal from knock sensor 1 is higher than expected for low load operation as defined in calibration. If this fault sets, spark is lowered by the amount defined in calibration for Faulted KNK Retard.

DTC 326-331: Troubleshooting Tree

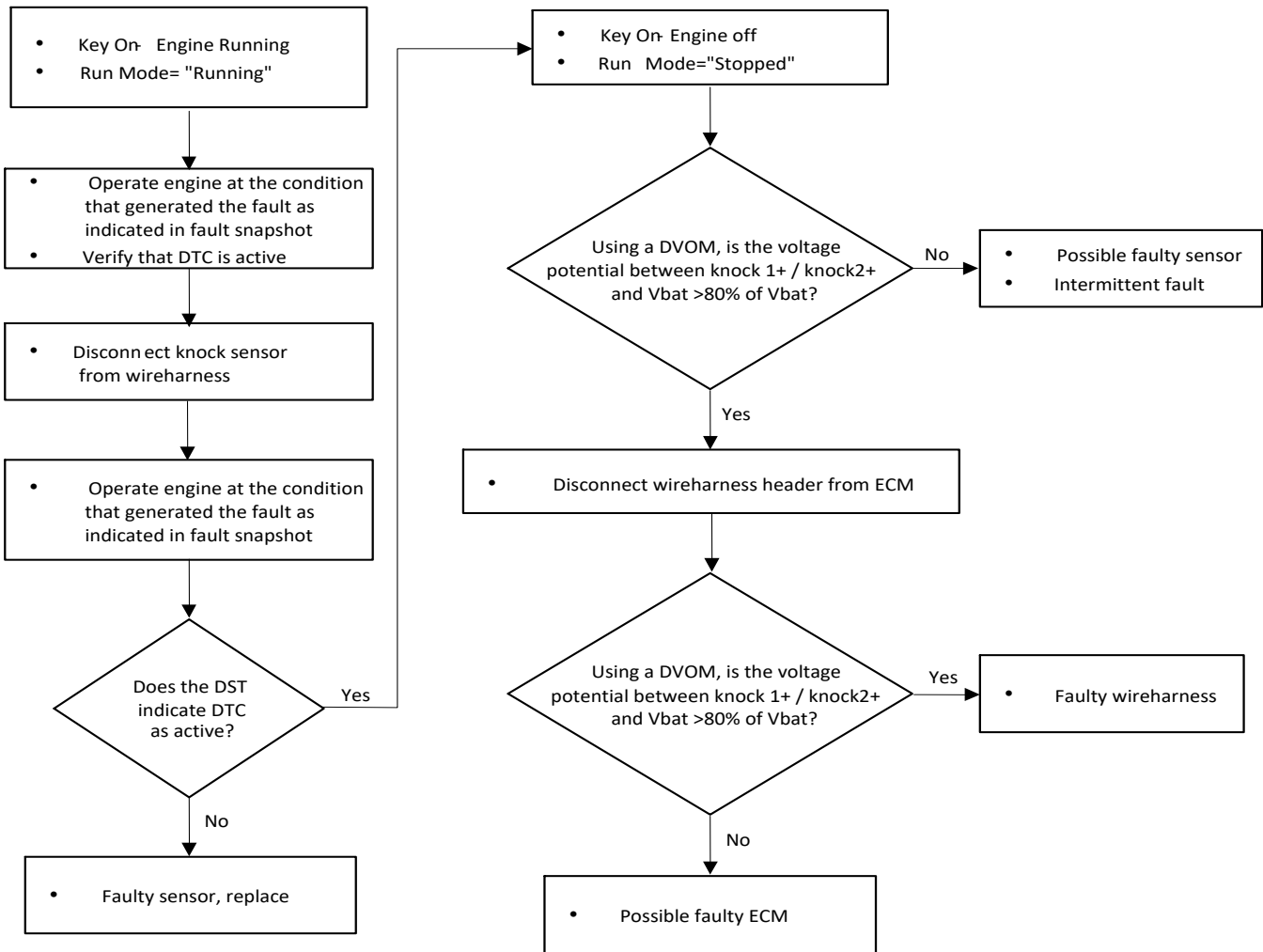

Code			Fault Description
DTC	SPN	FMI	
327	731	4	Knock 1 Open or Not Present
332	520197	4	Knock 2 Open or Not Present

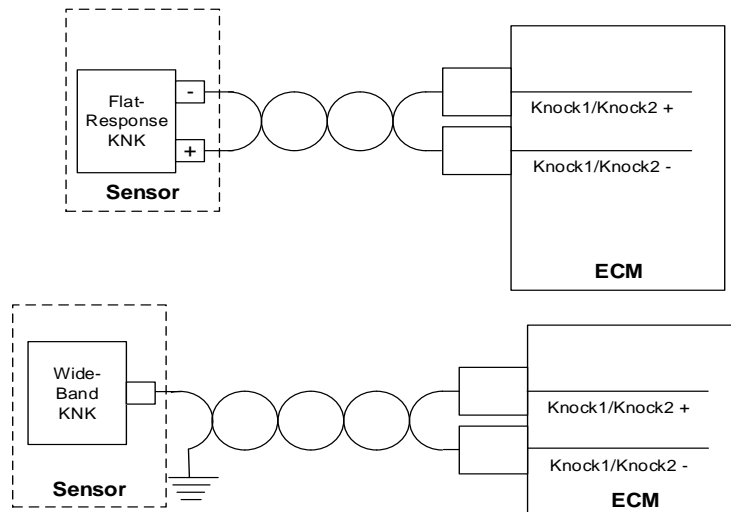

Hardware/Circuit Description:

The knock sensor is used to detect detonation through mechanical vibration in the engine block and/or cylinder heads and provide feedback for the ignition system to retard spark to reduce knock intensity. In most applications the knock sensor is used to protect the engine from damage that can be caused from detonation or knock based on fixed spark advance. In other applications, the knock sensor is used to optimize spark advance and “learn” between spark tables based on fuel quality.

Possible Causes:

This fault sets if the signal from knock sensor 1 is lower than expected for higher speed and load operation as defined in calibration. If this fault sets, spark is lowered by the amount defined in calibration for Faulted KNK Retard.

DTC 327-332: Troubleshooting Tree

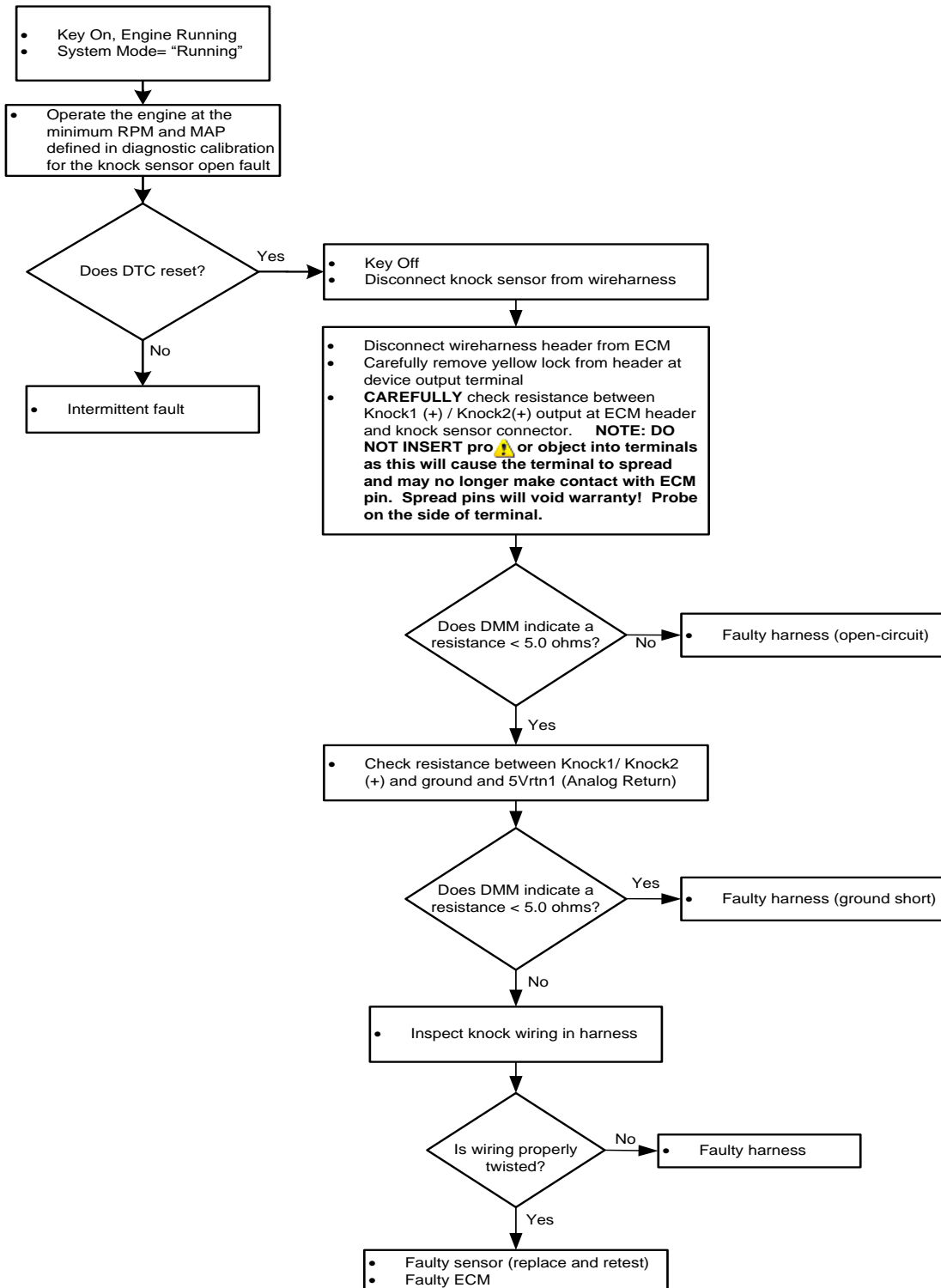

Code			Fault Description
DTC	SPN	FMI	
336	636	2	Crank Sync Noise

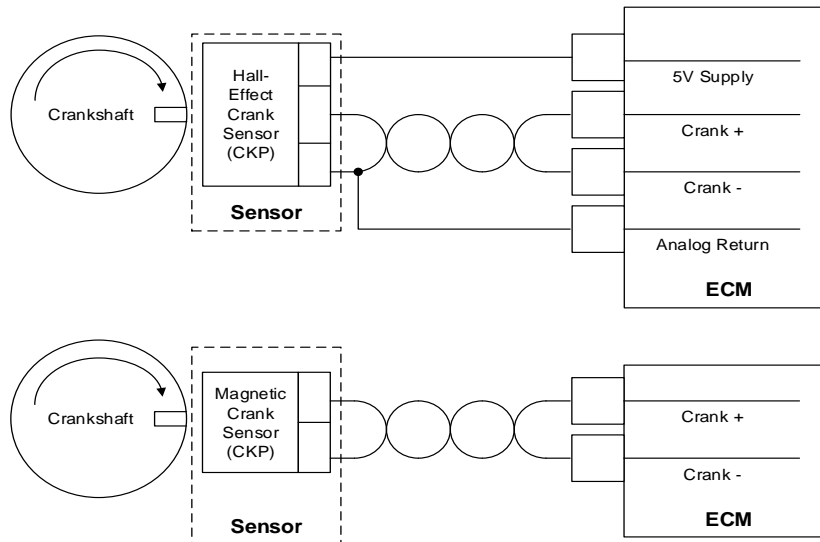

Hardware/Circuit:	Crankshaft Position sensor
--------------------------	----------------------------

Hardware/Circuit Description:	The crankshaft position sensor is a magnetic sensor (variable reluctance/magnetic pick-up or hall-effect) installed in the engine block adjacent to a “coded” trigger wheel located on the crankshaft. The sensor-trigger wheel combination is used to determine crankshaft position (with respect to TDC cylinder #1 compression) and the rotational engine speed. Determination of the crankshaft position and speed is necessary to properly activate the ignition, fuel injection, and throttle governing systems for precise engine control.
--------------------------------------	---

Possible Causes:	The ECM must see a valid crankshaft position signal while running. If no signal is present, the signal amplitude is too high (due to improper air gap with respect to trigger wheel), or an irregular crank pattern is detected causing the ECM to resynchronize x times for y ms or longer as defined in the diagnostic calibration, this fault will set. Irregular crank patterns can be detected by the ECM due to electrical noise, poor machining of trigger wheel, or trigger wheel runout and/or gear lash. Ensure crank circuit used with VR/magnetic pick-up sensors are properly twisted.
-------------------------	---

DTC 336: Troubleshooting Tree

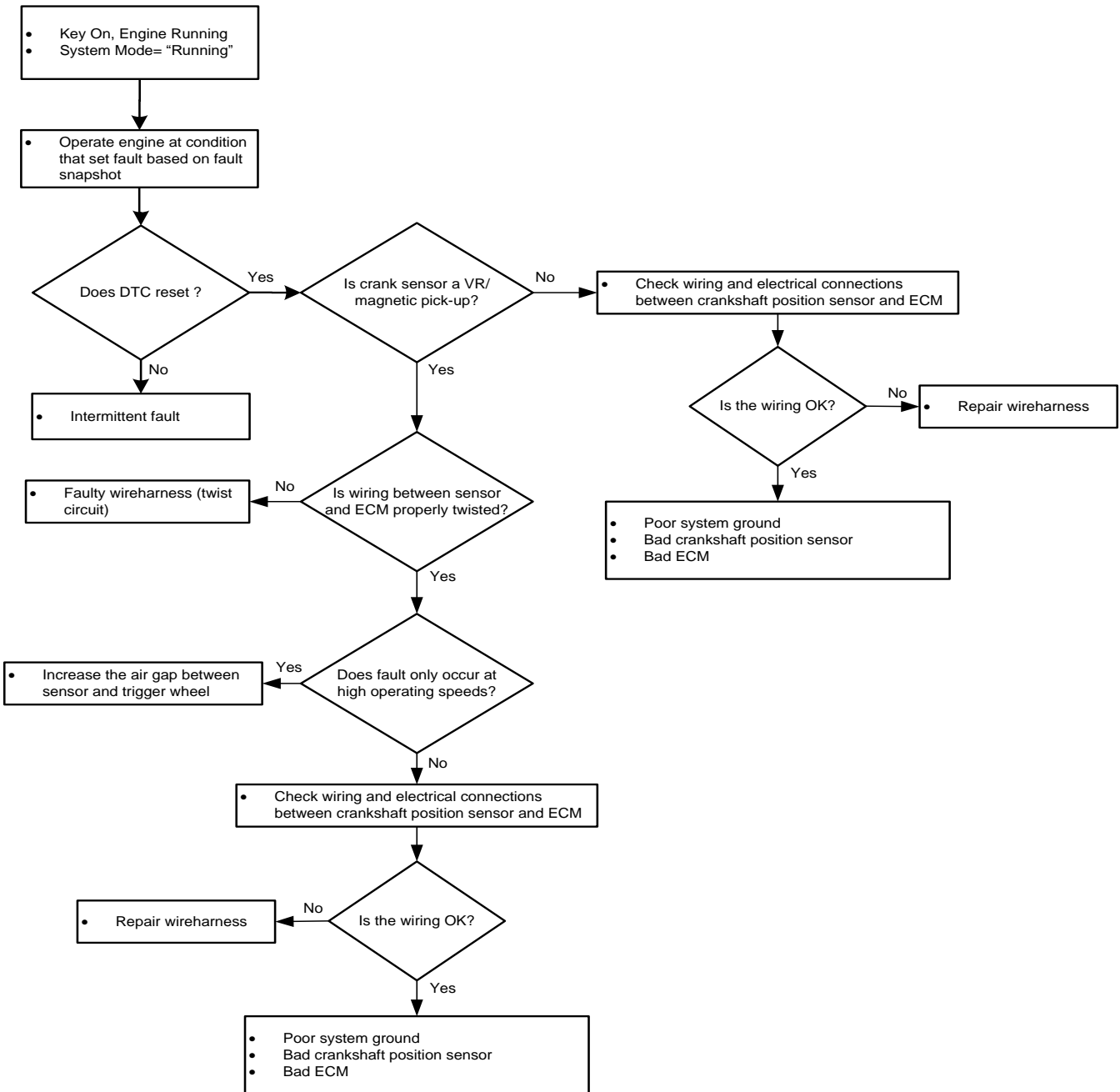

Code			Fault Description
DTC	SPN	FMI	
337	636	4	Crank Loss

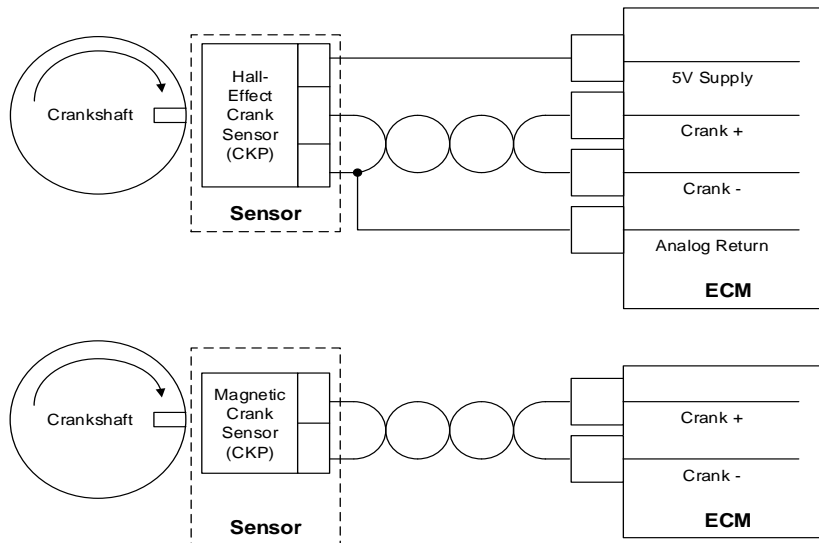

Hardware/Circuit:	Crankshaft Position sensor
--------------------------	----------------------------

Hardware/Circuit Description:	The crankshaft position sensor is a magnetic sensor (variable reluctance/magnetic pick-up or hall-effect) installed in the engine block adjacent to a “coded” trigger wheel located on the crankshaft. The sensor-trigger wheel combination is used to determine crankshaft position (with respect to TDC cylinder #1 compression) and the rotational engine speed. Determination of the crankshaft position and speed is necessary to properly activate the ignition, fuel injection, and throttle governing systems for precise engine control.
--------------------------------------	---

Possible Causes:	The ECM must see a valid crankshaft position signal while running. If no signal is present while x cam pulses continue the fault will set. The engine typically stalls or dies as a result of this fault condition due to the lack of crankshaft speed input resulting in the inability to control ignition timing.
-------------------------	---

DTC 337: Diagnostic Aids

Diagnostic Aids

- Check that crankshaft position sensor is securely connected to harness
- Check that crankshaft position sensor is securely installed into engine block
- Check crankshaft position sensor circuit wiring for open circuit

Code			Fault Description
DTC	SPN	FMI	
341	723	2	CAM Sync Noise

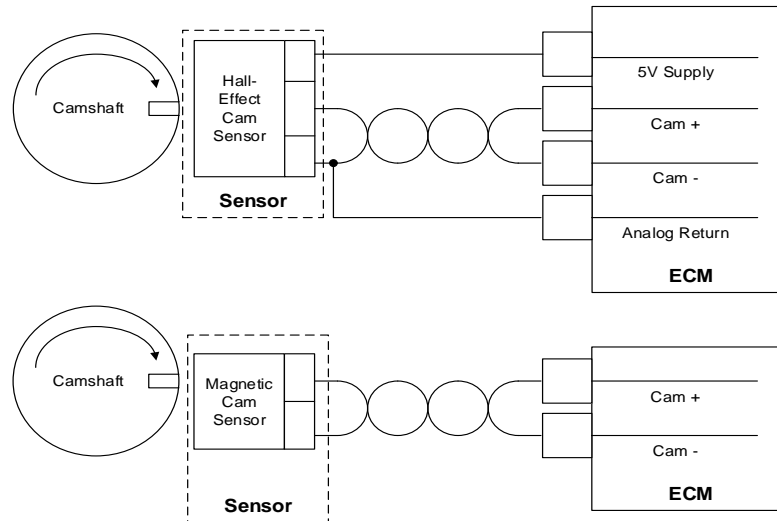

Hardware/Circuit:	Camshaft Position sensor
--------------------------	--------------------------

Hardware/Circuit Description:	<p>The camshaft position sensor is a magnetic sensor (variable reluctance/magnetic pick-up or hall-effect) installed in the engine block or valve train adjacent to a “coded” trigger wheel located on or off of the camshaft. The sensor-trigger wheel combination is used to determine cam position (with respect to TDC cylinder #1 compression). Determination of the camshaft position is necessary to identify the stroke (or cycle) of the engine to properly activate the fuel injection system and ignition (for coil-on-plug engines) for precise engine control.</p>
--------------------------------------	---

Possible Causes:	<p>For a cam synchronized engine, the ECM must see a valid camshaft position signal while running. If no signal is present, the signal amplitude is too high (due to improper air gap with respect to trigger wheel), or an irregular cam pattern is detected causing the ECM to resynchronize x times for y ms or longer as defined in the diagnostic calibration, this fault will set. Irregular cam patterns can be detected by the ECM due to electrical noise, poor machining of trigger wheel, or trigger wheel runout and/or gear lash. Normally the engine will continue to run if equipped with a waste-spark or distributor ignition system.</p> <p>In some instances this fault can cause rough engine operation and can cause the engine to stall or die if equipped with coil-on-plug ignition engines.</p> <p>Ensure cam circuit used with VR/magnetic pick-up sensors are properly twisted.</p>
-------------------------	--

DTC 341: Troubleshooting Tree

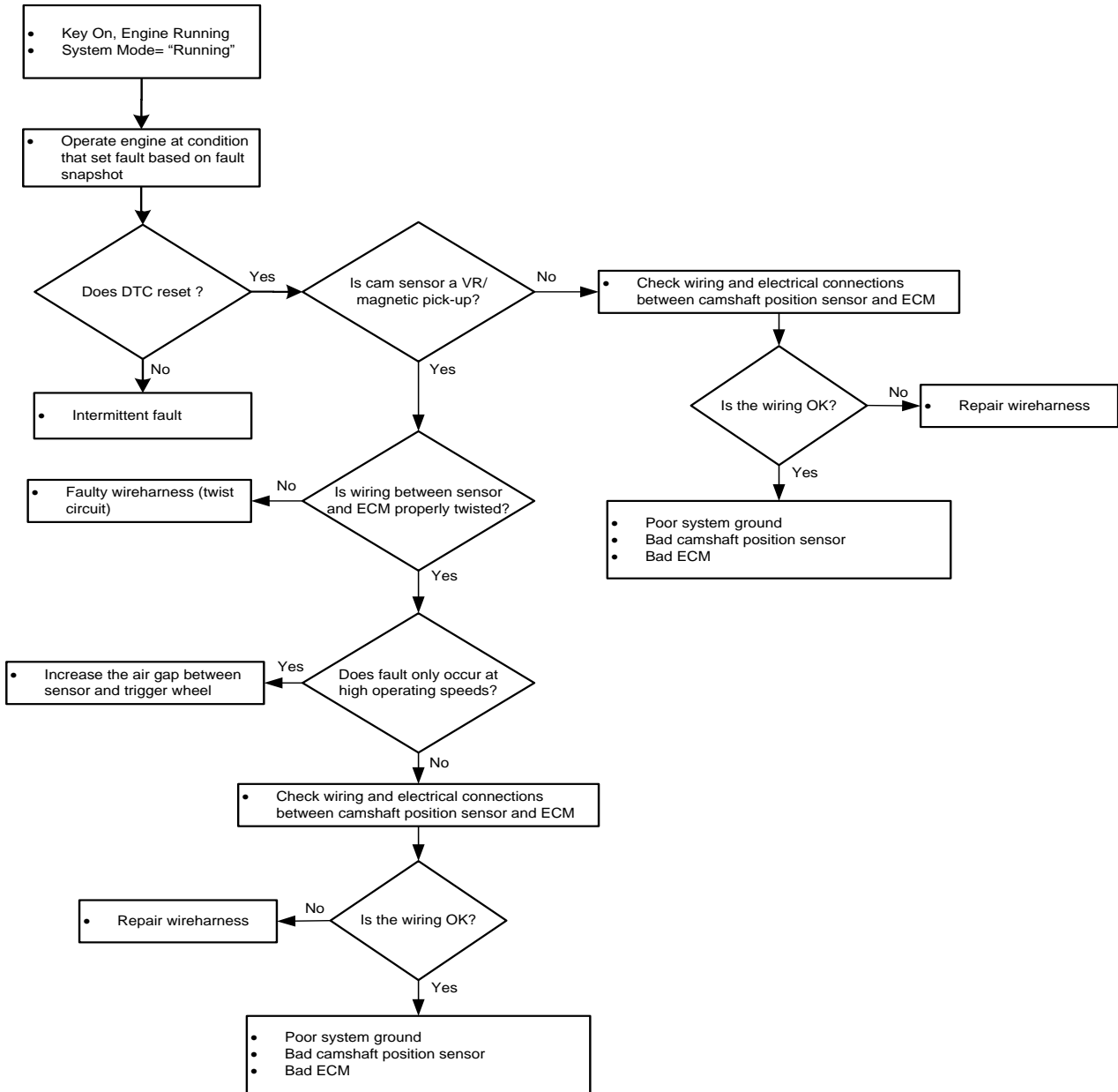

Code			Fault Description
DTC	SPN	FMI	
342	723	4	CAM Sync Noise (Intake)
367	723	4	CAM Sync Noise (Exhaust)

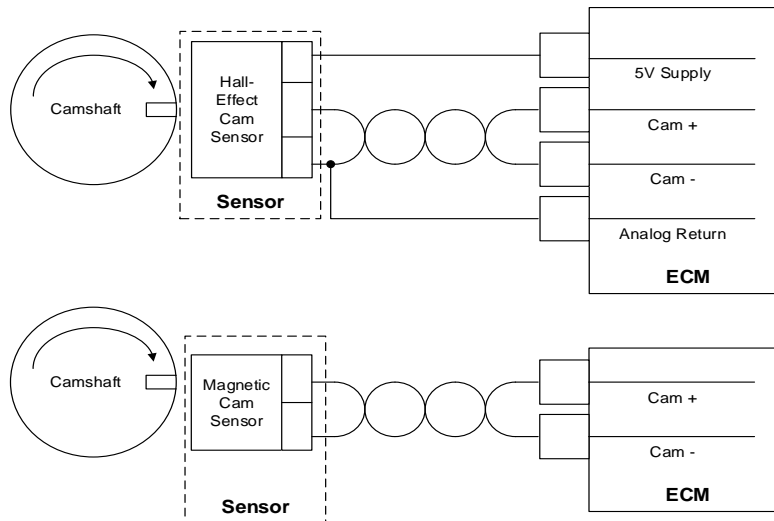

Hardware/Circuit:	Camshaft Position sensor
--------------------------	--------------------------

Hardware/Circuit Description:	<p>The camshaft position sensor is a magnetic sensor (variable reluctance/magnetic pick-up or hall-effect) installed in the engine block or valve train adjacent to a “coded” trigger wheel located on or off of the camshaft. The sensor-trigger wheel combination is used to determine cam position (with respect to TDC cylinder #1 compression). Determination of the camshaft position is necessary to identify the stroke (or cycle) of the engine to properly activate the fuel injection system and ignition (for coil-on-plug engines) for precise engine control.</p>
--------------------------------------	---

Possible Causes:	<p>For a cam synchronized engine, the ECM must see a valid camshaft position signal while running. This fault will set if valid crankshaft position data is received for x number of engine cycles while engine speed is greater than y RPM and no camshaft signal is received. Normally the engine will continue to run if equipped with a waste-spark or distributor ignition system. In some instances, this fault can cause rough engine operation and can cause the engine to stall or die if equipped with coil-on-plug ignition engines.</p>
-------------------------	---

DTC 342: Diagnostic Aid

Diagnostic Aids:

- Check that camshaft position sensor is securely connected to harness
- Check that camshaft position sensor is securely installed into engine block
- Check camshaft position sensor circuit wiring for open circuit

Code			Fault Description
DTC	SPN	FMI	
359	632	31	Fuel Run Out Longer Than Expected

Description:

The lock off valve will close immediately upon removal of ignition voltage. This fault will trigger if the engine continues to run for more than 20 seconds past the key off event.

Possible Causes:

Stuck open Lock off valve

Short to ground of valve ground side and short to power of positive side

Long distance between lock off valve and DEPR/Mixer

Circuit Description:

Ground is provided by Pin 77 of the ECU connector (White/Black Wire)

12V + is (Red/Lt Green Wire), from VSW F2 Fuse (5A)

Code			Fault Description
DTC	SPN	FMI	
420	3050	11	Gasoline CAT Monitor

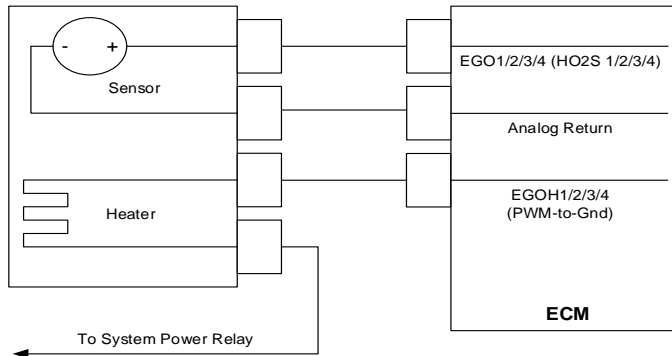

Hardware/Circuit:	Bank 1 Catalyst, Heated or Universal Exhaust Gas Oxygen Sensor (Bank 1-Sensor 2-After Catalyst) Bank 2 Catalyst, Heated or Universal Exhaust Gas Oxygen Sensor (Bank 2-Sensor 2-After Catalyst)
--------------------------	--

Hardware/Circuit Description:	<p>A catalyst or catalytic converter is a component in the exhaust subsystem used to accelerate/generate chemical reactions within the engine exhaust to convert undesirable gases/pollutants into less harmful gases. In many spark-ignited applications, a three-way catalyst is used to convert hydrocarbons, oxides of nitrogen, and carbon monoxide into nitrogen, water, and carbon dioxide. In addition, many low-emission applications require the use of OBD, which typically require a catalyst monitor to identify whether or not the catalyst is functioning properly. The catalyst monitor diagnostic is typically configured such that exhaust emissions are near compliance-failing levels based on the engines specific regulatory requirement(s). Catalyst monitor techniques typically utilize a HEGO sensor to monitor the amount of oxygen present downstream of the catalyst. This is generally a good indicator of how efficiently the catalyst is using the oxygen entering the catalyst. Some systems also use temperature measurements in the catalyst and compare it to data stored in the ECM for each operating condition to determine if the catalytic reaction is generating the proper amount of heat.</p> <p>The GCP uses a HEGO/HO2S sensor for catalyst monitor. The HEGO/HO2S is a switching-type sensor around stoichiometry that measures the oxygen content downstream of the catalyst for two main functions: 1) to compare it to the oxygen content upstream of the catalyst to determine how efficiently the catalyst is using oxygen to determine its effectiveness and 2) trim the commanded equivalence ratio target to maximize the catalyst conversion efficiency. The post-catalyst strategy and diagnostic is only active when the system is in either "CL Active" or "CL + Adapt" control modes.</p>
--------------------------------------	---

Possible Causes:

In theory if the catalyst is operated at a condition that could result in 100 percent conversion efficiency, the catalyst will use all available oxygen present in the exhaust gas to convert the emission pollutants (or reactants) to N₂, CO₂, and H₂O. However, since catalysts generally operate at efficiencies between 85-95% post-catalyst oxygen concentration can be a direct indicator of how efficient the catalyst is. Below is an example of a slightly rich biased feed gas or pre-catalyst equivalence ratio versus that of the post-catalyst for a functional catalyst.

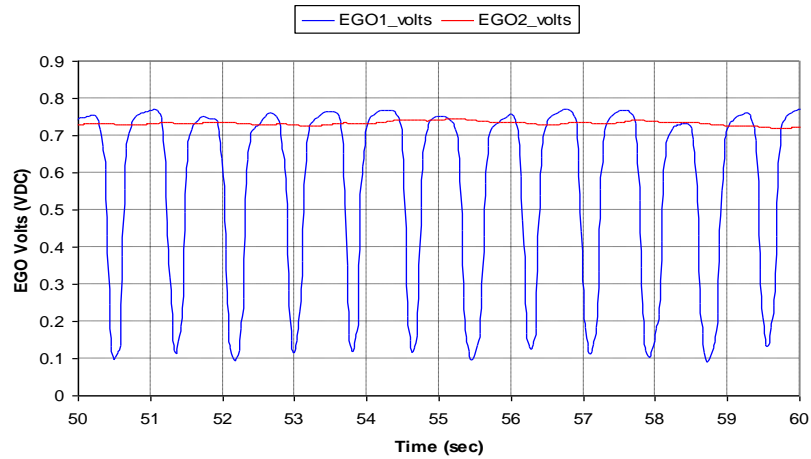

It can be noticed from this figure that the pre-catalyst equivalence ratio, as identified by 'EGO1_volts', is varying due to the CL excursions (perturbation) and that the post-catalyst equivalence ratio, as identified by 'EGO2_volts', is maintained relatively constant rich of stoichiometry. A similar waveform pattern should be expected on properly functioning catalysts.

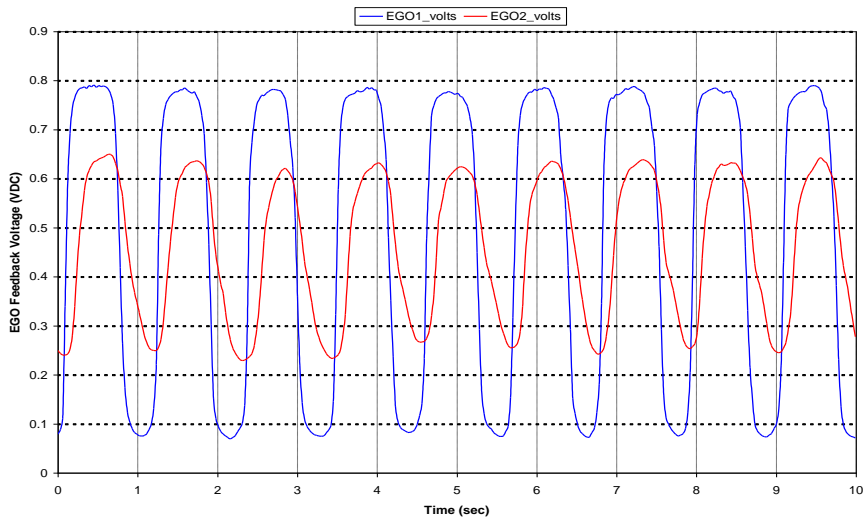

Figure 3: EGO Waveforms (Damaged TWC)

A significant difference between the two plots shown is that the post-catalyst EGO feedback oscillates with the same frequency as the pre-catalyst EGO feedback and the amplitude is on the order of 60% of that of EGO1. This indicates that a certain amount of oxygen that is entering into the catalyst is passing through the catalyst unconsumed. Catalyst monitor diagnostics are configured such that if the post-catalyst EGO waveform has an amplitude that is directly proportional to the pre-catalyst EGO waveform and whose waveform similarly matches the closed-loop excursion (perturbation) a fault is generated.

Two metric comparisons that are used to identify the health of the catalyst are:

1) Post-catalyst EGO root-mean square (RMS) > Pre-catalyst EGO RMS x [TBD]%, where the [TBD]% is determined based on emissions compliance testing over the application's certified duty-cycle(s).

2) Post-catalyst EGO RMS > CL excursion RMS x [TBD]%, where the [TBD]% is determined based on emissions compliance testing over the application's certified duty-cycle(s).

There are a couple of ways in which the limits for diagnostics can be determined. In both cases, the system must be tested with an emissions measurement system to determine when the exhaust emissions are nearly failing emissions compliance.

Diagnostic Aids

NOTE: If any other DTCs are present, diagnose those first.

Exhaust Leak – Pressurize exhaust system with 1-2 psig of air and check for pressure leaks upstream and around catalyst and post-catalyst HEGO sensor. Replace gaskets and tighten fasteners if leaks are present.

Perform manufacture recommended in-field emissions test.

Code			Fault Description
DTC	SPN	FMI	
524	100	1	Oil Pressure Low (Switch)

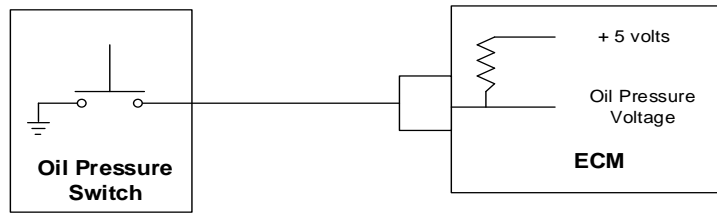

**Normally-Open
Switch-Type**

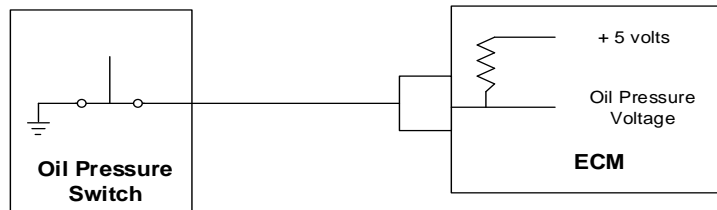

**Normally-Closed
Switch-Type**

Hardware/Circuit:	Engine Oil Pressure
--------------------------	---------------------

Hardware/Circuit Description:	The ECM can be configured to monitor oil pressure through a proportional transducer or through a switch. Oil pressure monitoring is important to prevent engine damage due to low oil pressure resulting in higher friction and lack of lubrication. In addition, high oil pressure can be undesirable because it can cause oil to leak past seals and rings, can be a result of a restriction in the oil flow path, or can be a sign of a malfunctioning oiling system.
--------------------------------------	--

Possible Causes:	For systems that use a switch this fault can be configured two different ways. It may use a normally closed switch or a normally open switch. If the switch is normally open, the fault will set if the circuit becomes grounded. If the switch is normally closed, the fault will set if the circuit becomes open. The engine should be configured to de-rate or force idle and/or shut down in the event of this fault to help prevent possible damage.
-------------------------	---

DTC 524: Troubleshooting Tree

Trouble Tree (Normally-Open Switch)

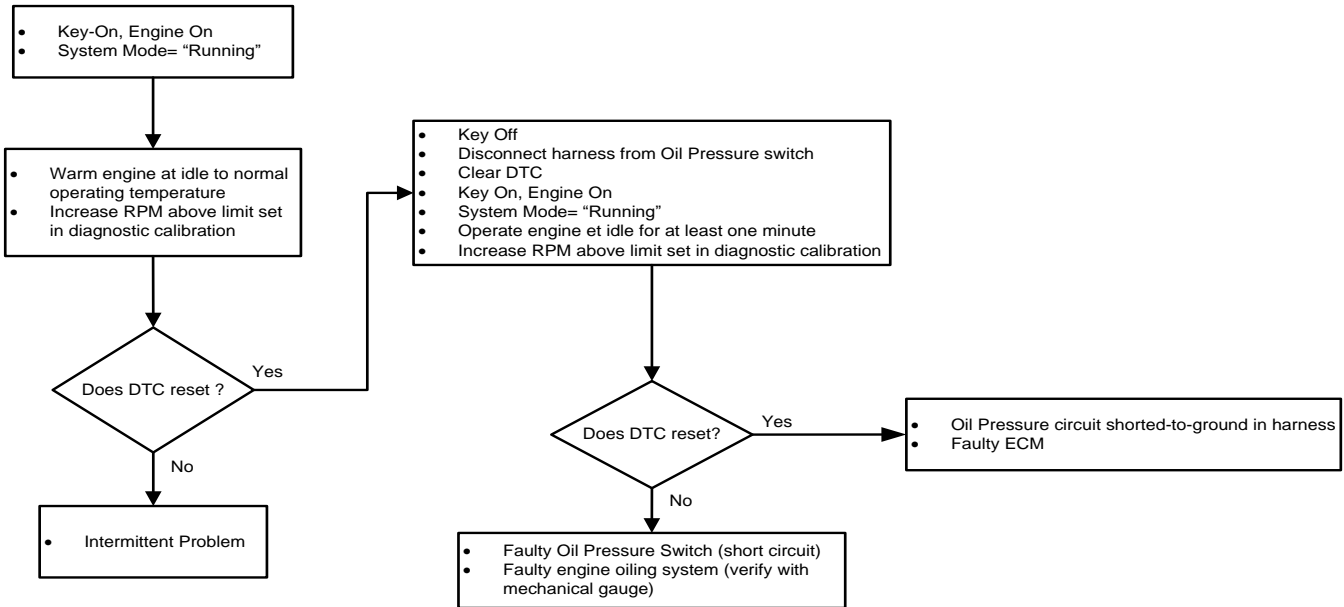

Trouble Tree (Normally-Closed Switch)

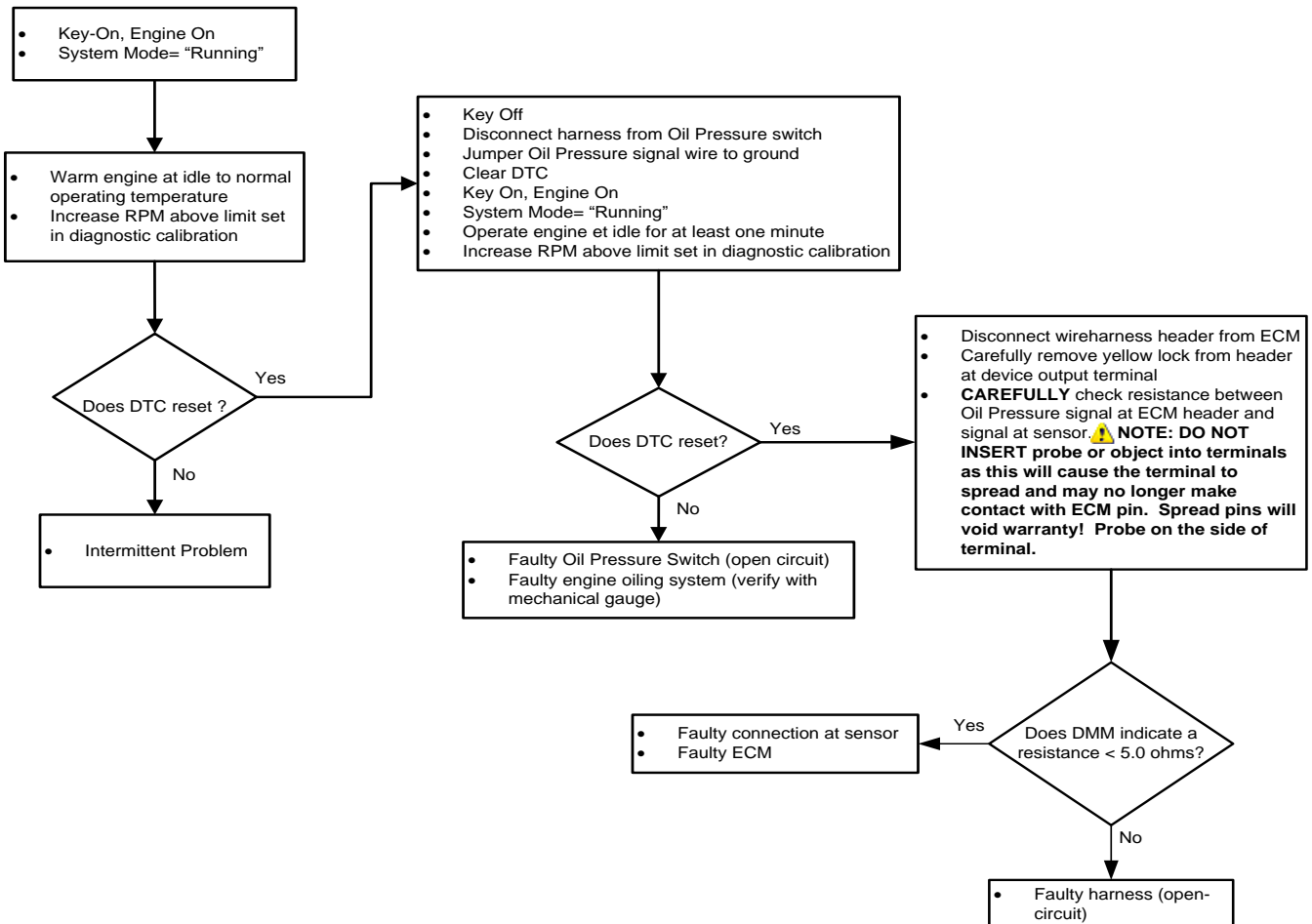

Code			Fault Description
DTC	SPN	FMI	
562	168	17	Battery Voltage Low

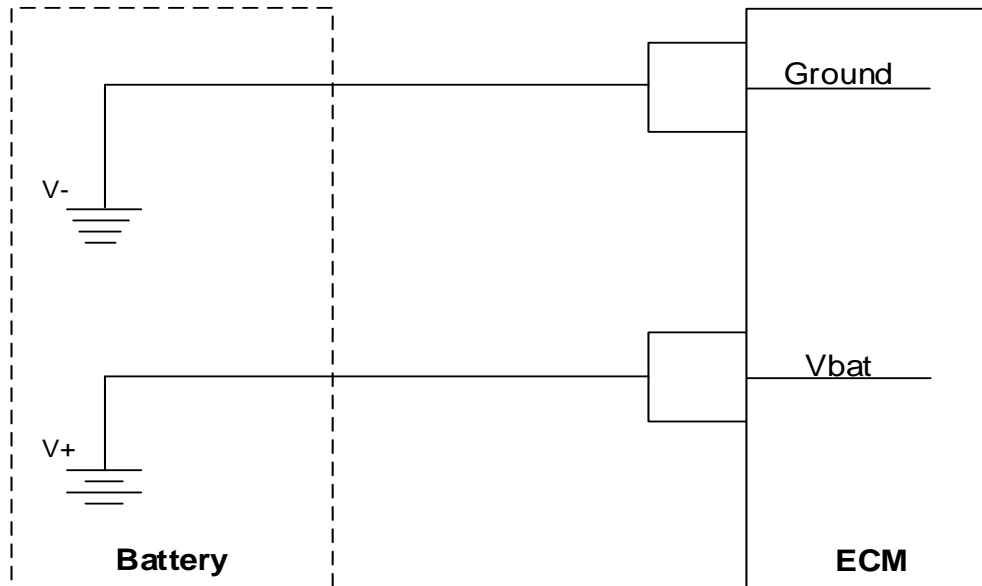

Hardware/Circuit:	System Voltage to ECM
--------------------------	-----------------------

Hardware/Circuit Description:	The battery voltage powers the ECM and must be within limits to correctly operate injector drivers, ignition coils, throttle, power supplies, and other powered devices that the ECM controls.
--------------------------------------	--

Possible Causes:	This fault will set if the ECM detects system voltage less than x volts while the engine is operating at y RPM as defined in the diagnostic calibration as the alternator should be charging the system. The adaptive learn is disabled to avoid improper adaptive learning due to the inability to correctly time injector firings.
-------------------------	--

DTC 562: Troubleshooting Tree

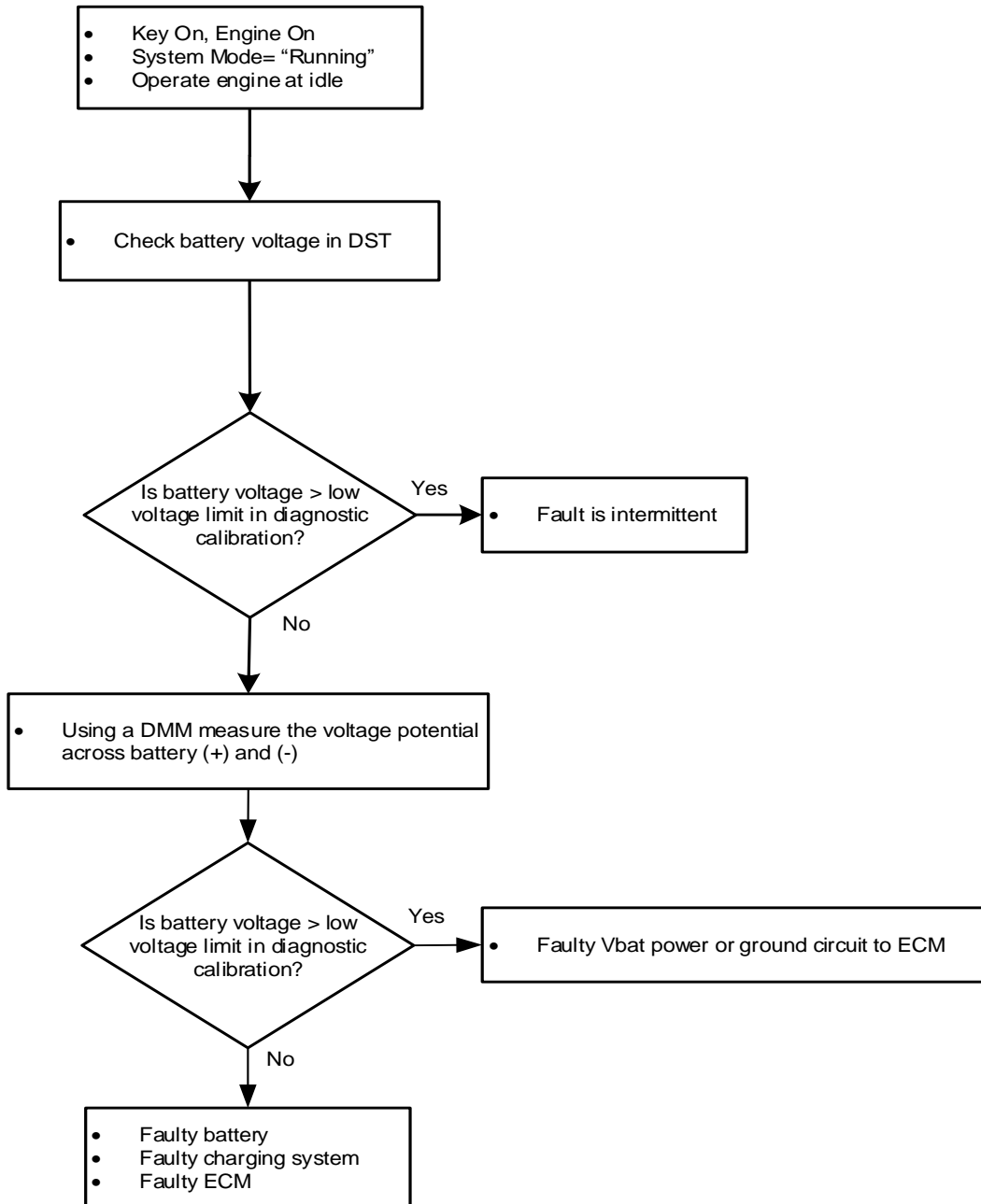

Code			Fault Description
DTC	SPN	FMI	
563	168	15	Battery Voltage High

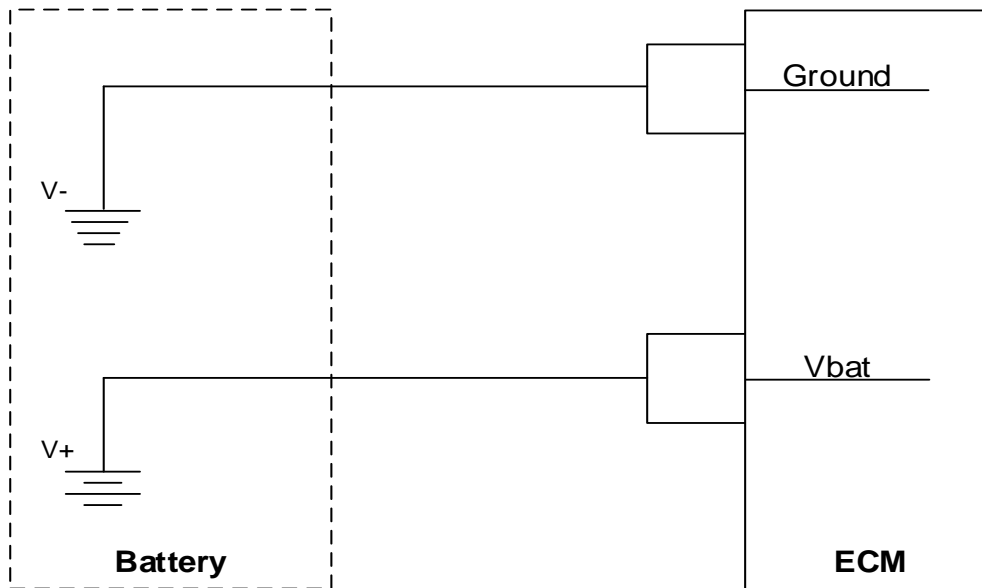

Hardware/Circuit:	System Voltage to ECM
--------------------------	-----------------------

Hardware/Circuit Description:	The battery voltage powers the ECM and must be within limits to correctly operate injector drivers, ignition coils, throttle, power supplies, and other powered devices that the ECM controls.
--------------------------------------	--

Possible Causes:	This fault will set if the ECM detects system voltage greater than x volts while the engine is running or cranking as defined in the diagnostic calibration. The adaptive learn is disabled to avoid improper adaptive learning.
-------------------------	--

DTC 563: Troubleshooting Tree

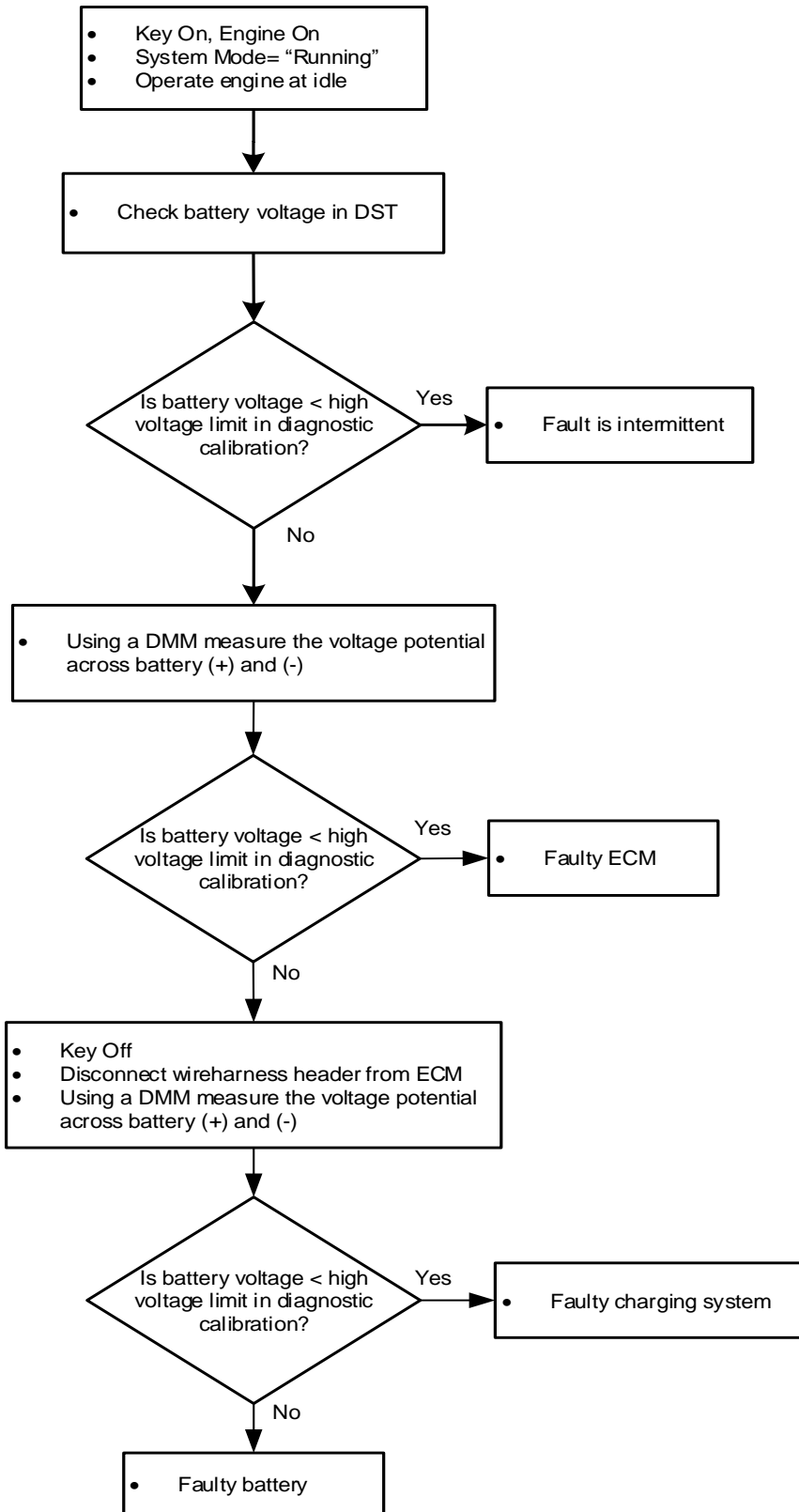

Code			Fault Description
DTC	SPN	FMI	
601	628	13	Microprocessor Failure - Flash Checksum Invalid

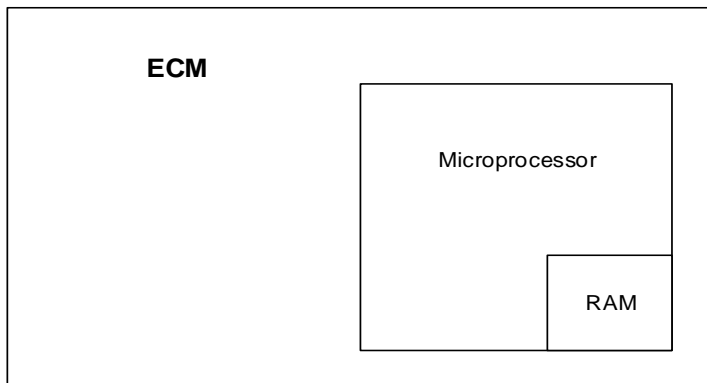

Hardware/Circuit:	Engine Control Module – Flash Memory
--------------------------	--------------------------------------

Hardware/Circuit Description:
The ECM has checks that must be satisfied each time an instruction is executed. Several different things can happen within the microprocessor that will cause this fault.
NOTE: This fault is not implemented in the 4G System.

Code			Fault Description
DTC	SPN	FMI	
604	630	12	Microprocessor Failure - RAM Failure

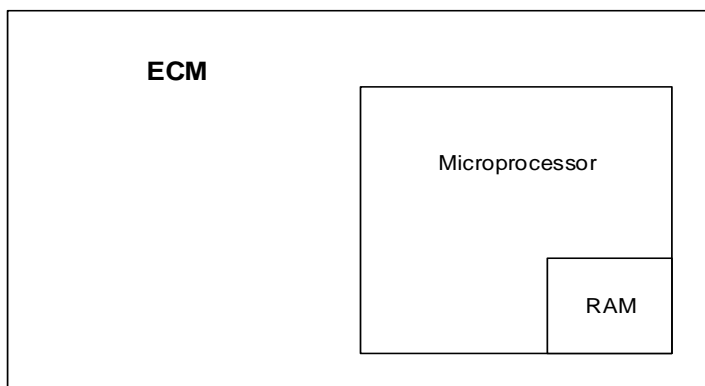

Hardware/Circuit:	Engine Control Module – Random Access Memory
--------------------------	--

Hardware/Circuit Description:
<p>Random Access Memory is located within the microprocessor and can be read from or written to at any time. Data stored in RAM include DTCs (when fault configuration is set to “Battery Power Retained”), adaptive fuel learn tables, octane adaptation table, misfire adaption tables, and closed loop fuel multipliers. The ECM has checks that must be satisfied each time an instruction is executed.</p>
<p>NOTE: This fault is not implemented in the 4G System.</p>

Code			Fault Description
DTC	SPN	FMI	
606	629	31	Microprocessor Failure - COP Failure

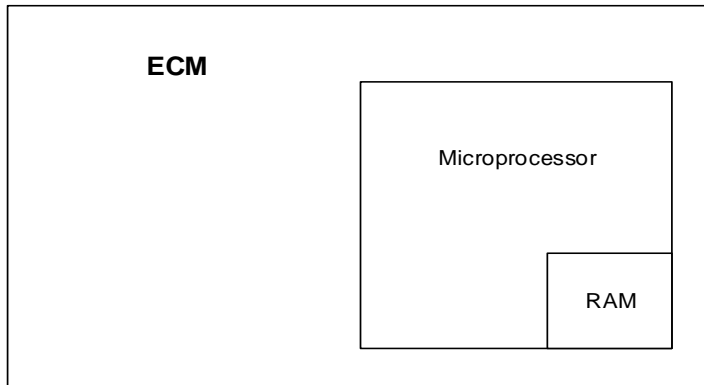

Hardware/Circuit:	The ECM has a watchdog timer to ensure execution of the embedded software is completing within an allotted timeframe.
--------------------------	---

Hardware/Circuit Description:	
<p>If this fault sets, the ECM will reset itself and log the code. The fault should be configured to never forget and will not self-erase and will not clear until a technician performs diagnostics and manually clears the code. This fault should be configured to set a power derate 2 and low rev limit to reduce possible engine damage and reduce possibility of an overspeed condition.</p>	

DTC 606: Troubleshooting Tree

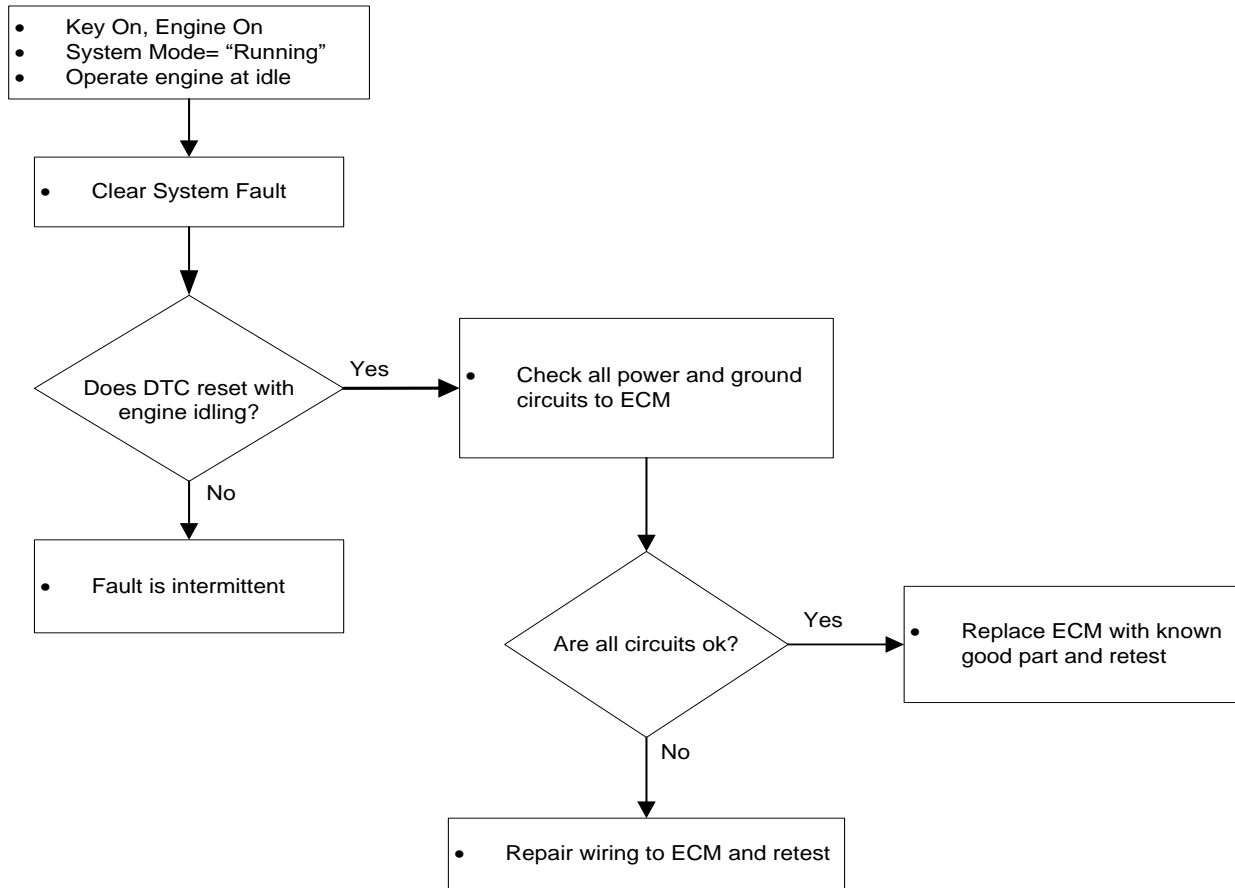

Code			Fault Description
DTC	SPN	FMI	
615	1321	5	Start Relay Coil Open

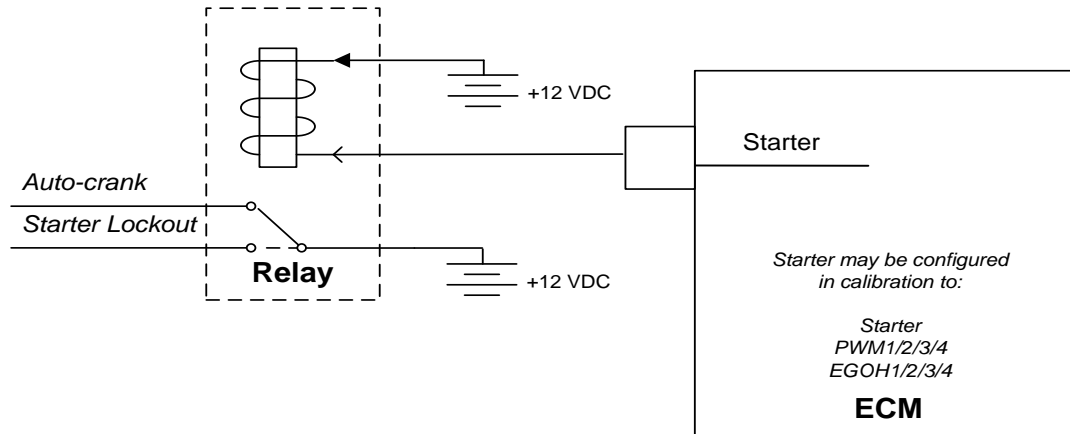

Hardware/Circuit:	Starter Relay
--------------------------	---------------

Hardware/Circuit Description:	The ECM has auxiliary low-side drivers that can turn on warning devices or ground electromagnetic relay coils to control power to devices connected to the engine.
--------------------------------------	--

Possible Causes:	This fault sets if the output for the starter relay is detected as an open circuit. If this fault is active the starter motor will not receive power and will not engage.
-------------------------	---

DTC 615: Troubleshooting Tree

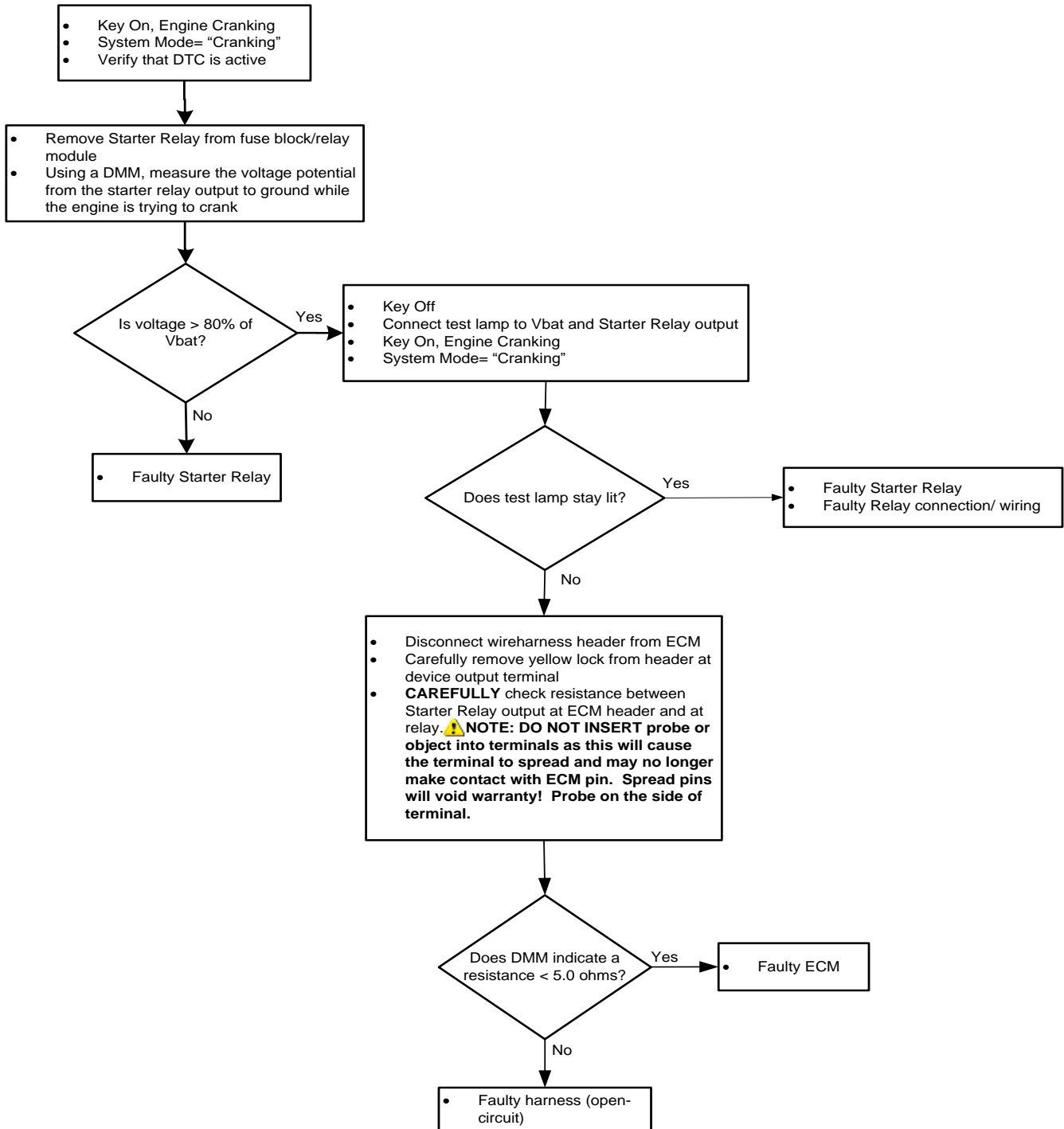

Code			Fault Description
DTC	SPN	FMI	
616	1321	4	Start Relay Coil Ground Short

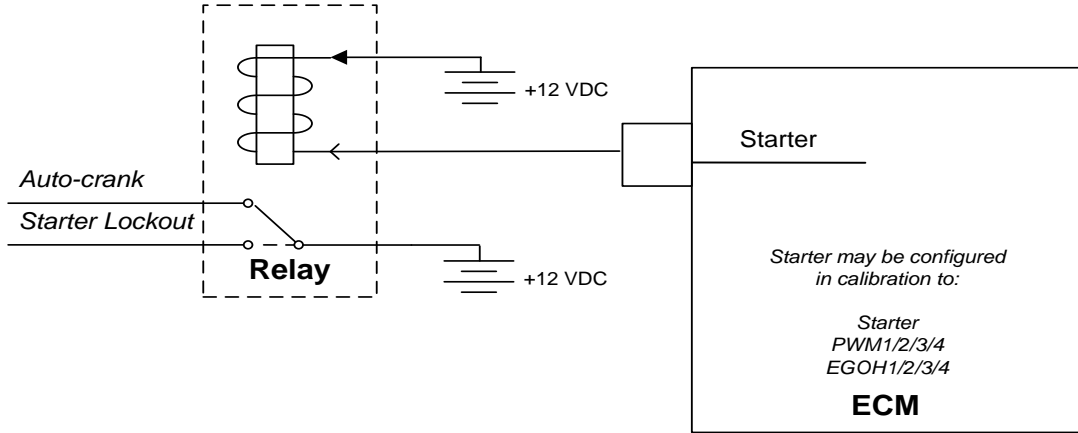

Hardware/Circuit:	Starter Relay
--------------------------	---------------

Hardware/Circuit Description:	The ECM has auxiliary low-side drivers that can turn on warning devices or ground electromagnetic relay coils to control power to devices connected to the engine.
--------------------------------------	--

Possible Causes:	This fault sets if the output for the starter relay is detected as an open circuit. If this fault is active the starter motor will not receive power and will not engage.
-------------------------	---

DTC 616: Troubleshooting Tree

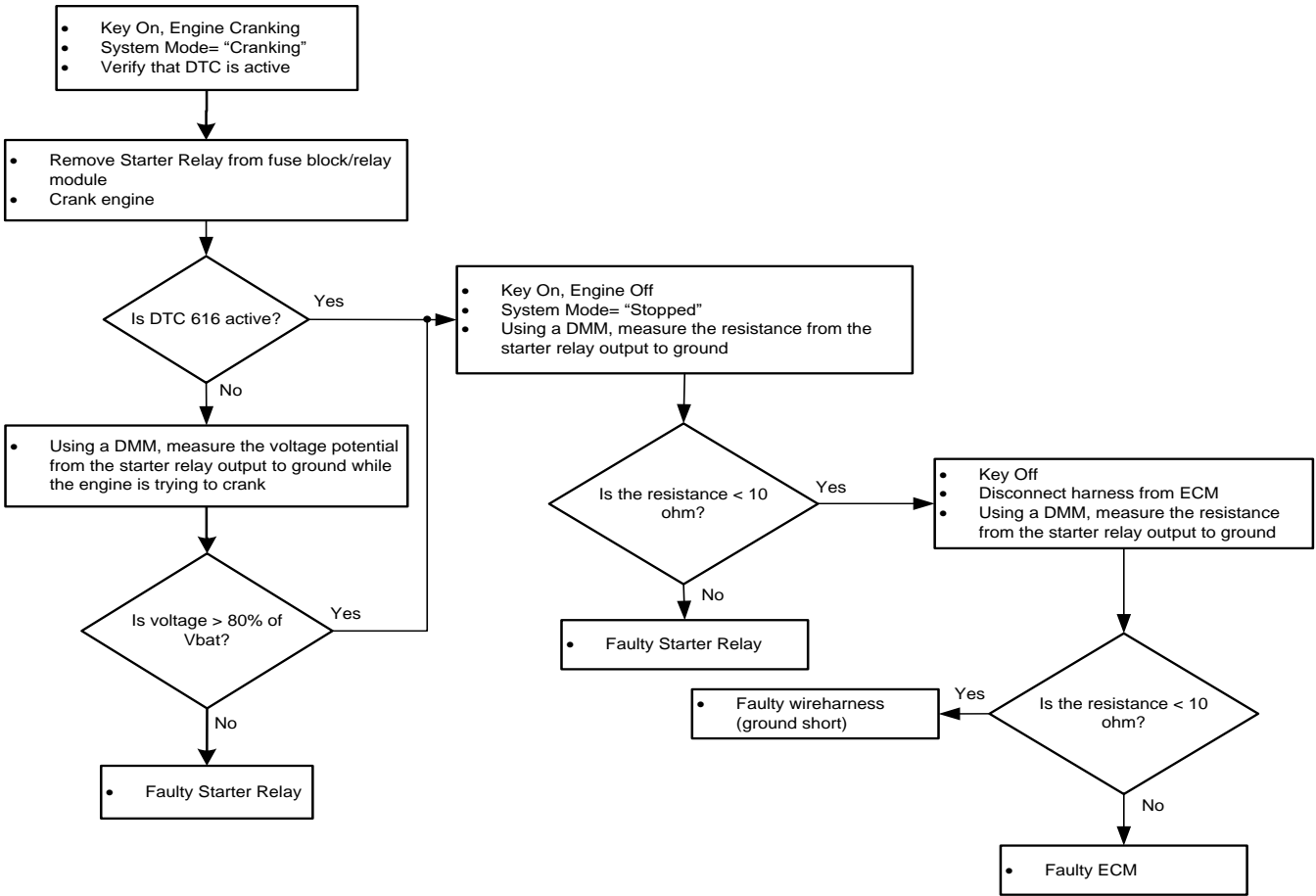

Code			Fault Description
DTC	SPN	FMI	
617	1321	3	Start Relay Coil Short to Power

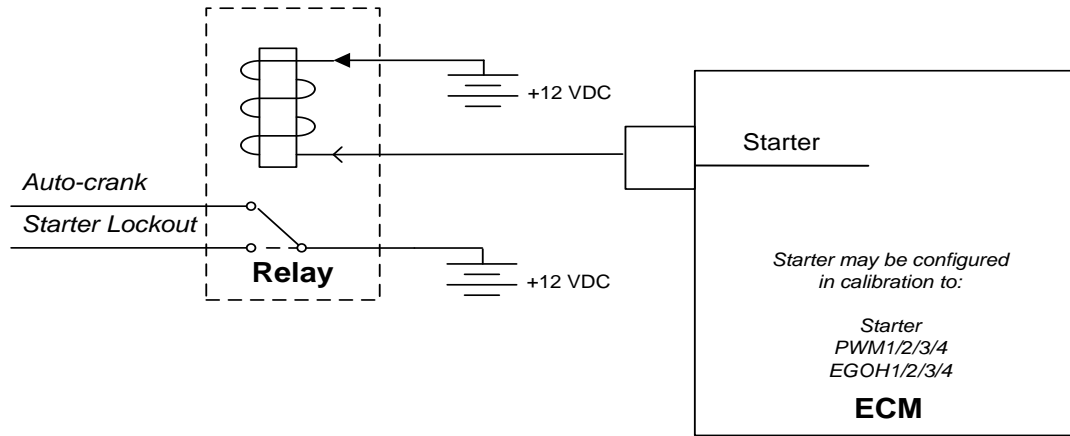

Hardware/Circuit:	Starter Relay
--------------------------	---------------

Hardware/Circuit Description:	The ECM has auxiliary low-side drivers that can turn on warning devices or ground electromagnetic relay coils to control power to devices connected to the engine.
--------------------------------------	--

Possible Causes:	This fault sets if the output for the starter relay is detected as shorted to power. If this fault is active the starter motor will not receive power and will not engage.
-------------------------	--

DTC 617: Troubleshooting Tree

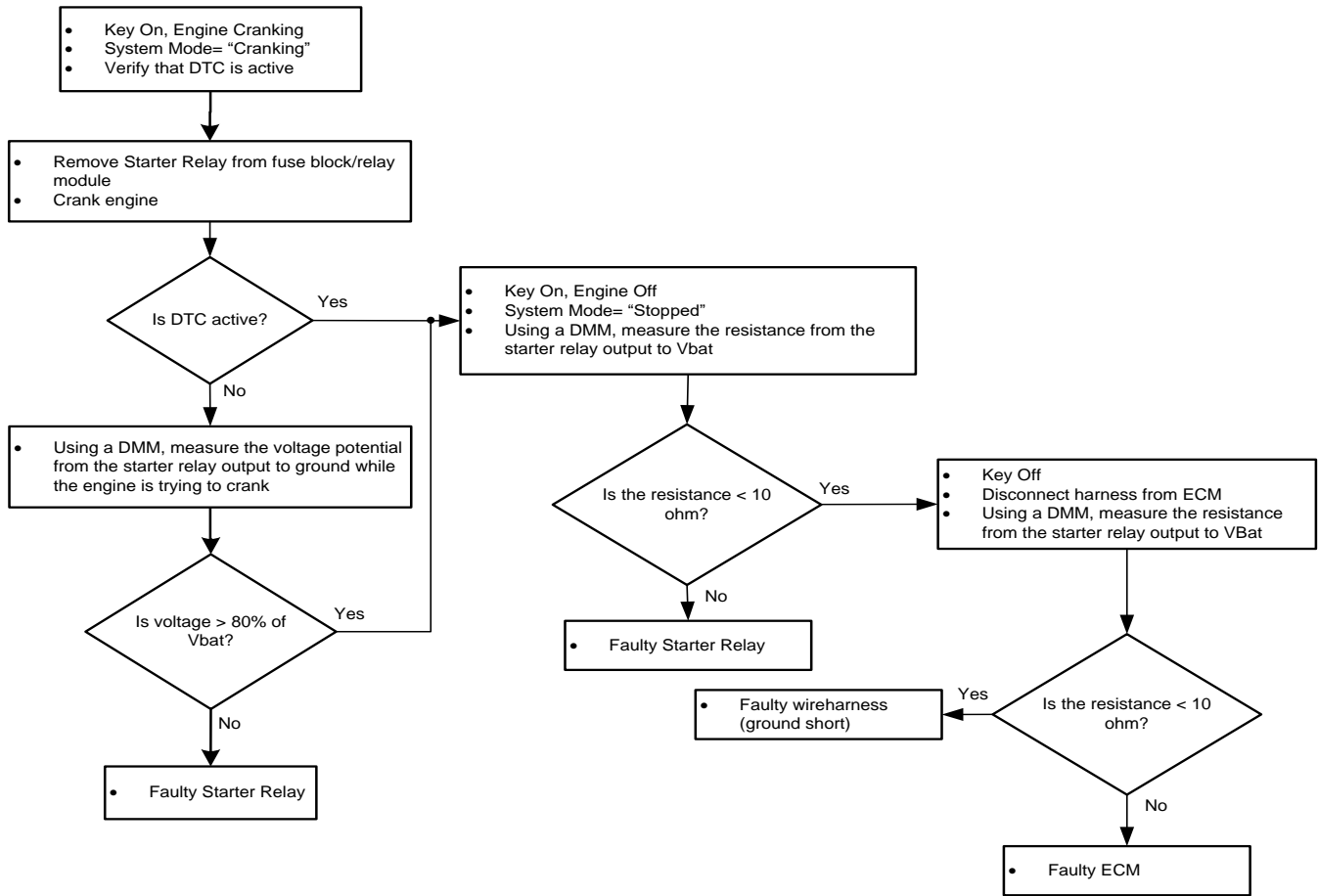

Code			Fault Description
DTC	SPN	FMI	
627	1348	5	Fuel Pump Relay Coil Open

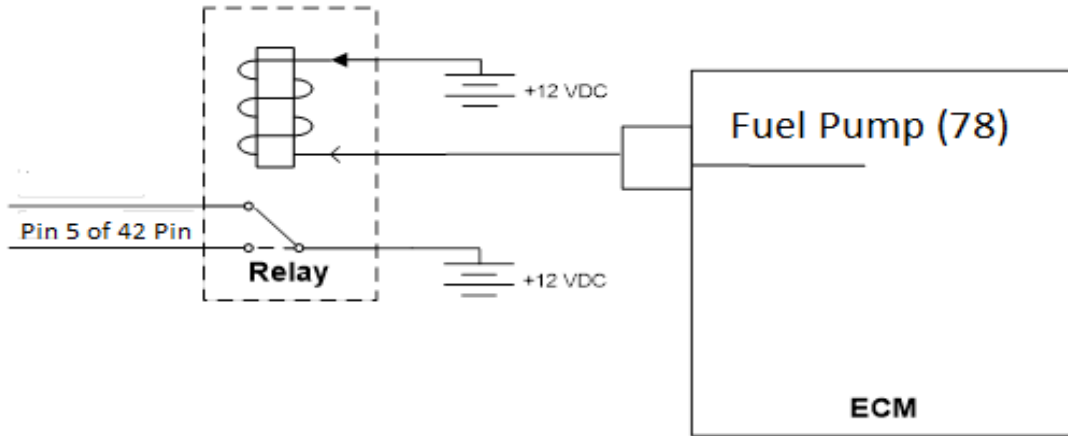

Hardware/Circuit:	Fuel Pump Relay
--------------------------	-----------------

Hardware/Circuit Description:	The ECM has auxiliary low-side drivers that can turn on warning devices or ground electromagnetic relay coils to control power to devices connected to the engine.
--------------------------------------	--

Possible Causes:	This fault sets if the output for the fuel relay is detected as shorted to power. If this fault is active the starter motor will not receive power and will not engage.
-------------------------	---

DTC 627: Troubleshooting Tree

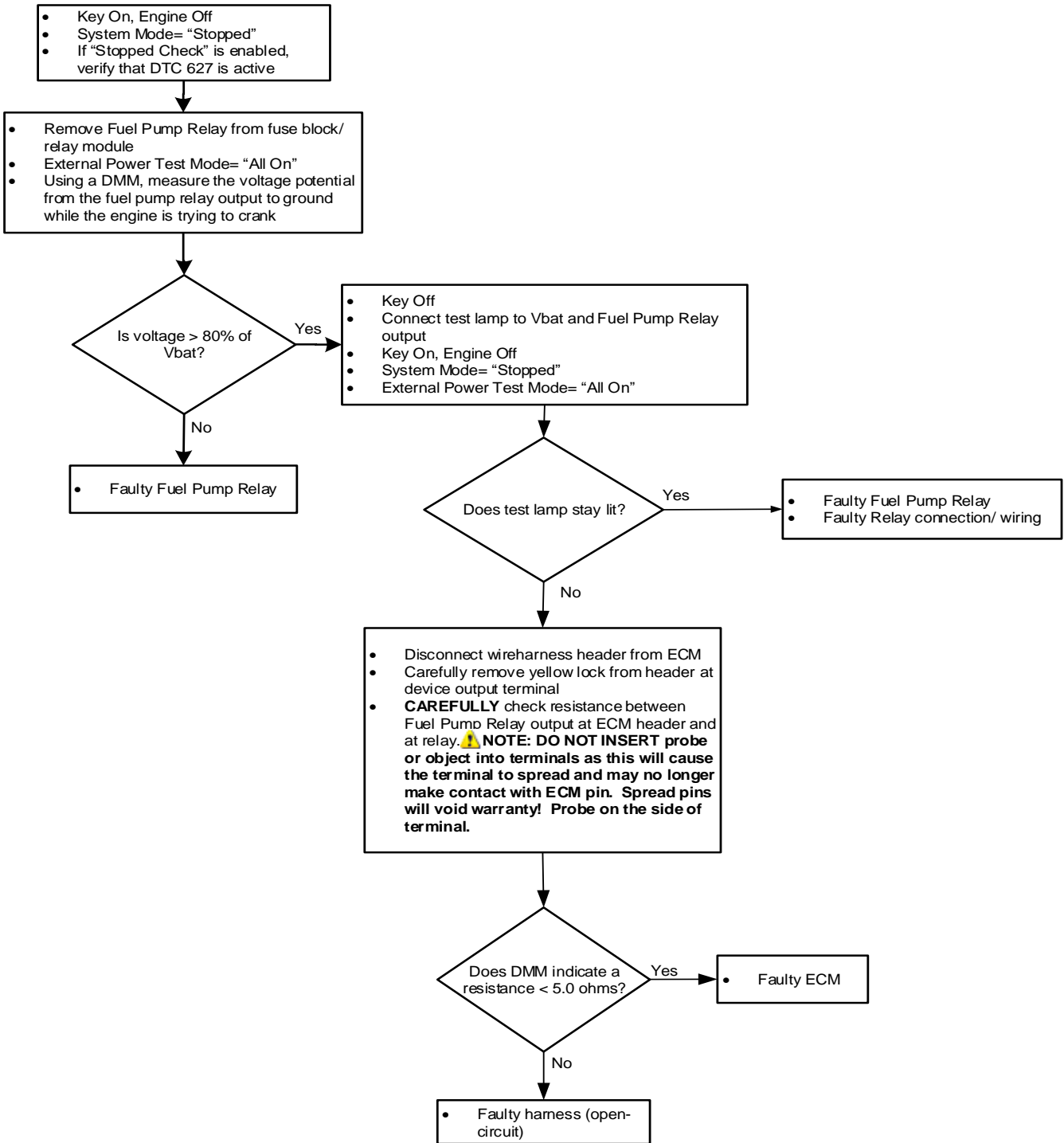

Code			Fault Description
DTC	SPN	FMI	
628	1348	4	Fuel Pump Relay Control Ground Short

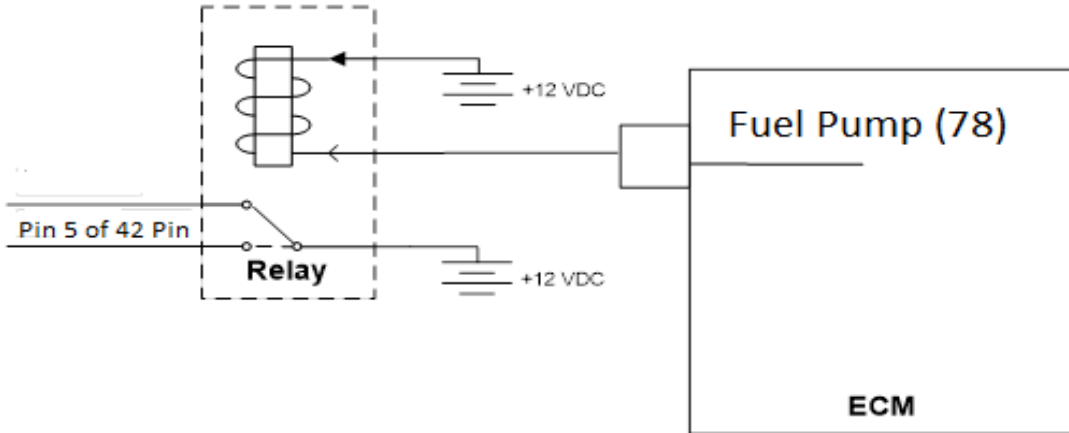

Hardware/Circuit:	Fuel Pump Relay
--------------------------	-----------------

Hardware/Circuit Description:	The ECM has auxiliary low-side drivers that can turn on warning devices or ground electromagnetic relay coils to control power to devices connected to the engine.
--------------------------------------	--

Possible Causes:	This fault sets if the output for the fuel pump relay is detected as being shorted to ground. If this fault is active and the high-side of the fuel pump relay is supplied, the fuel pump will run until the relay or high-side power is removed.
-------------------------	---

DTC 628: Troubleshooting Tree

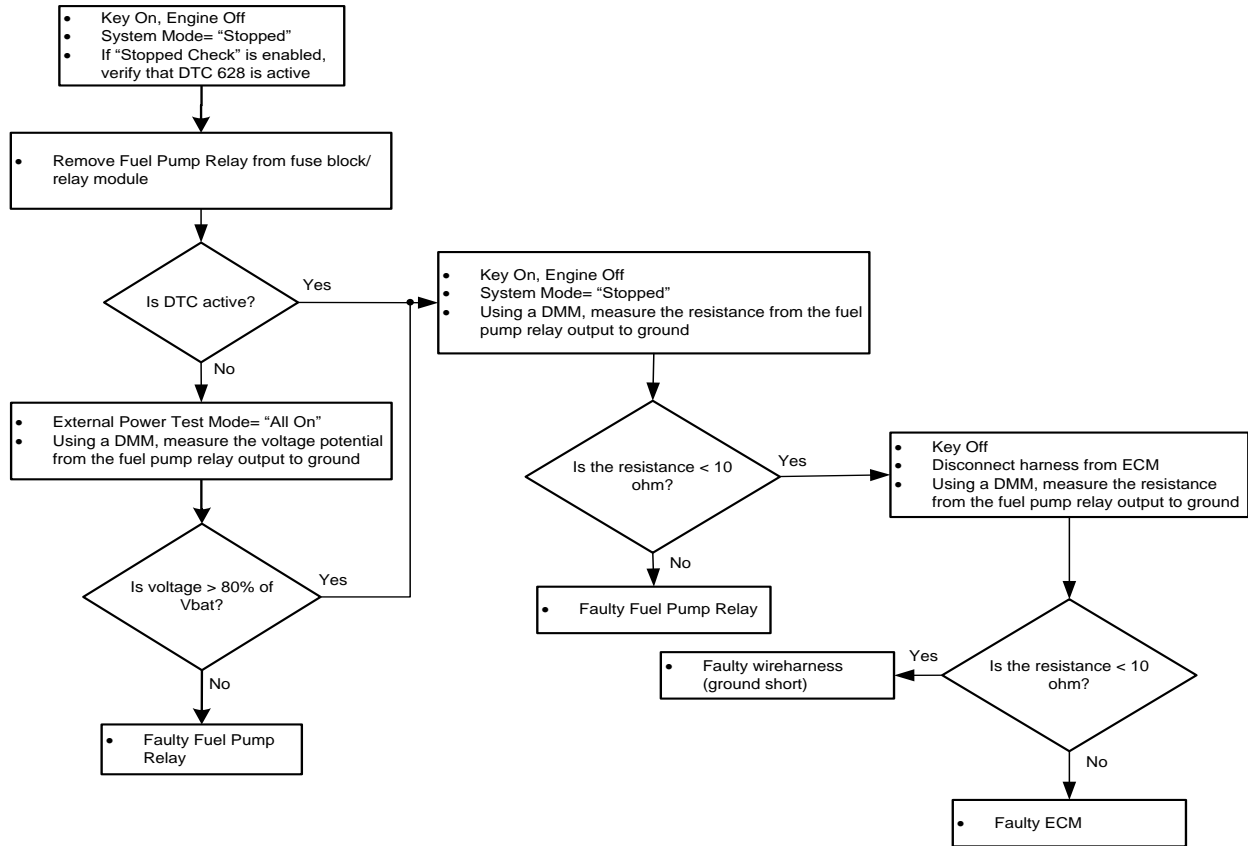

Code			Fault Description
DTC	SPN	FMI	
629	1348	3	Fuel Pump Relay Coil Short-To-Power

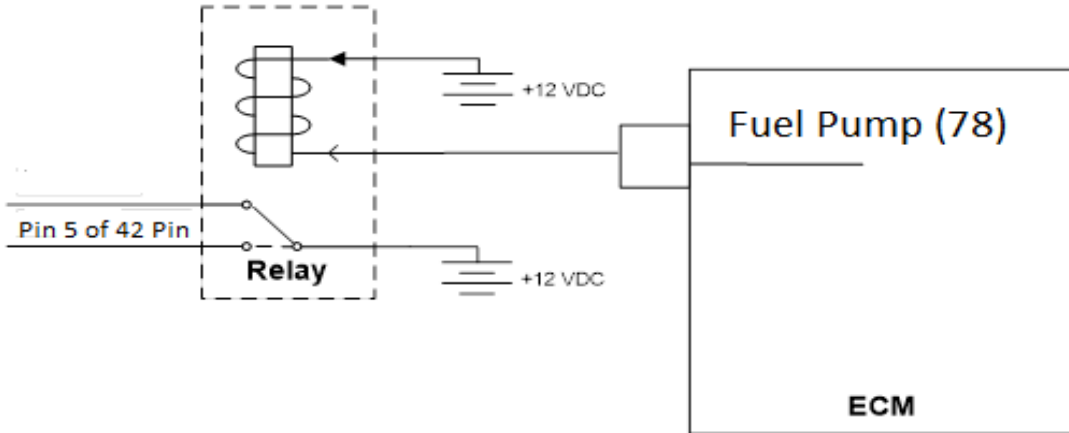

Hardware/Circuit:	Fuel Pump Relay
--------------------------	-----------------

Hardware/Circuit Description:	The ECM has auxiliary low-side drivers that can turn on warning devices or ground electromagnetic relay coils to control power to devices connected to the engine.
--------------------------------------	--

Possible Causes:	This fault sets if the output for the fuel pump relay is detected as shorted to power. If this fault is active the fuel pump will not receive power and will not run.
-------------------------	---

DTC 629: Troubleshooting Tree

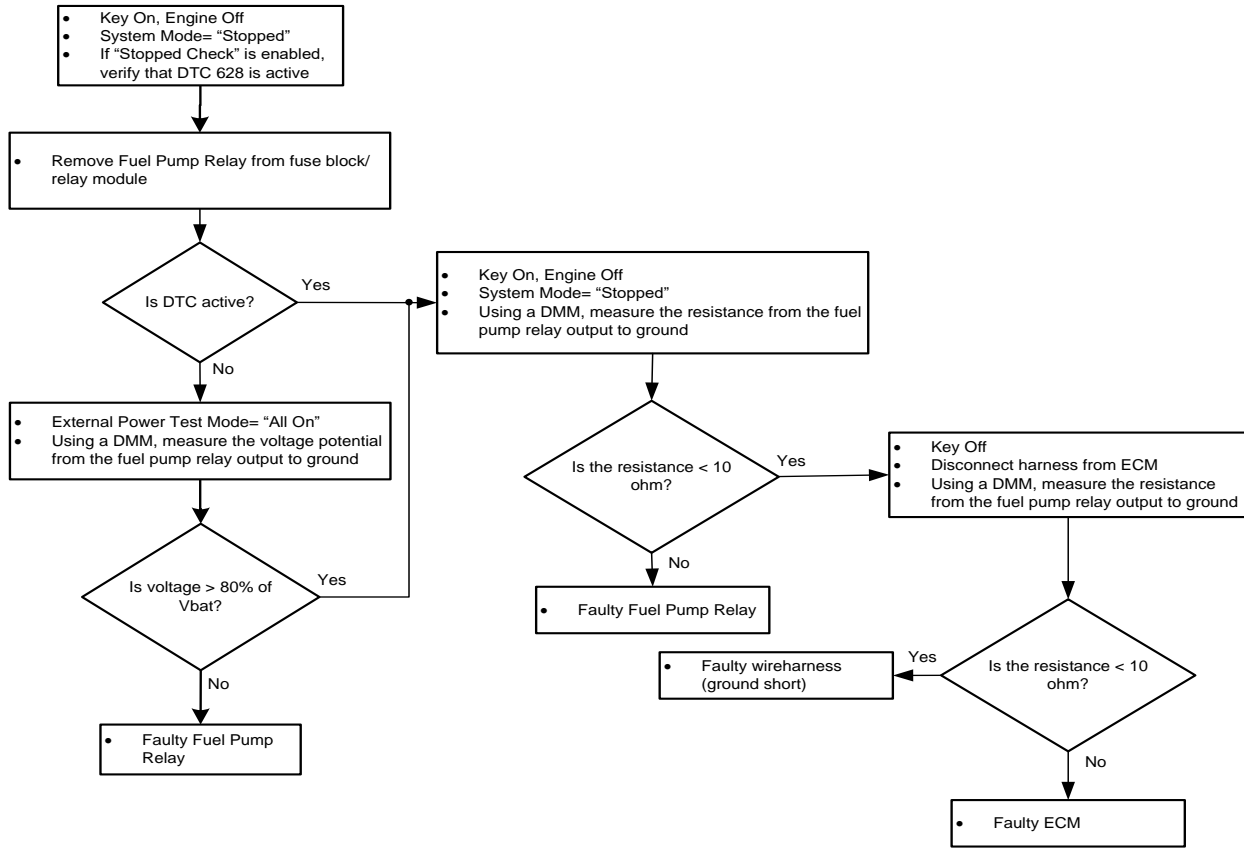

Code			Fault Description
DTC	SPN	FMI	
642	1079	4	Sensor Supply Voltage 1 Low

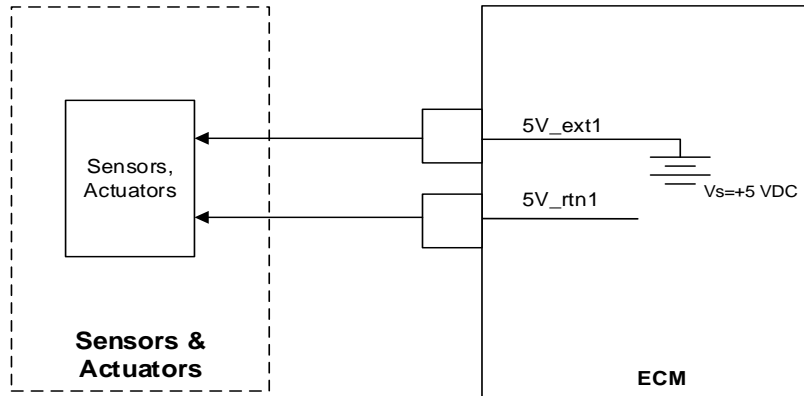

Hardware/Circuit:	External Sensor Supply Voltage Regulator
--------------------------	--

Hardware/Circuit Description:	The external 5-volt supply powers sensors and other components in the engine control system. The accuracy of this supply is critical to the accuracy of the sensors' feed-back, therefore, it is supplied from a precision regulator whose output is internally monitored by the ECM. The ECM monitors the 5-volt supply to ratio metrically correct sensor
--------------------------------------	---

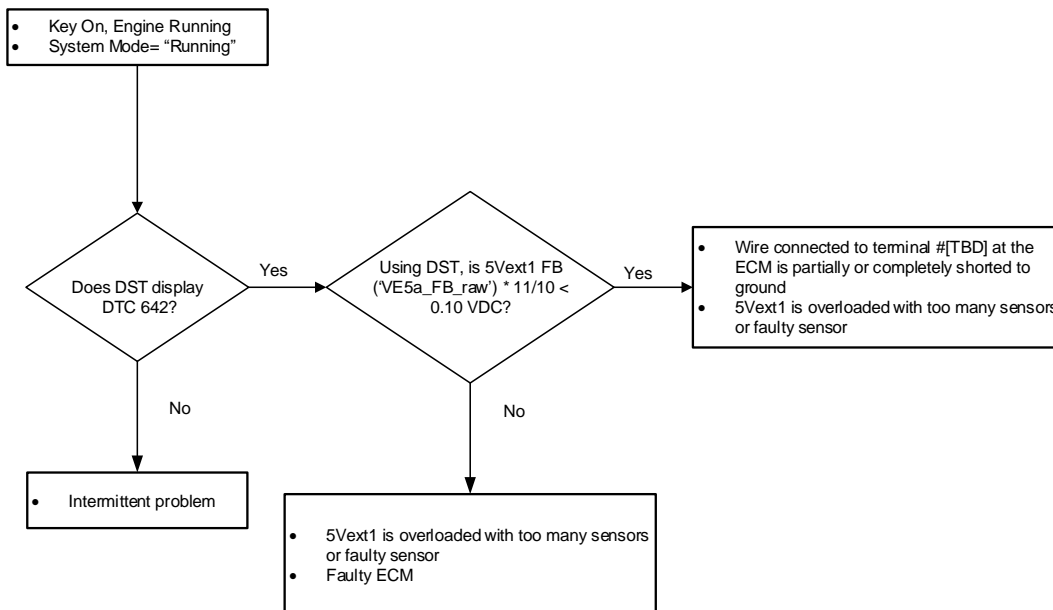

Code			Fault Description
DTC	SPN	FMI	
643	1079	3	5V Sensor Supply Voltage High

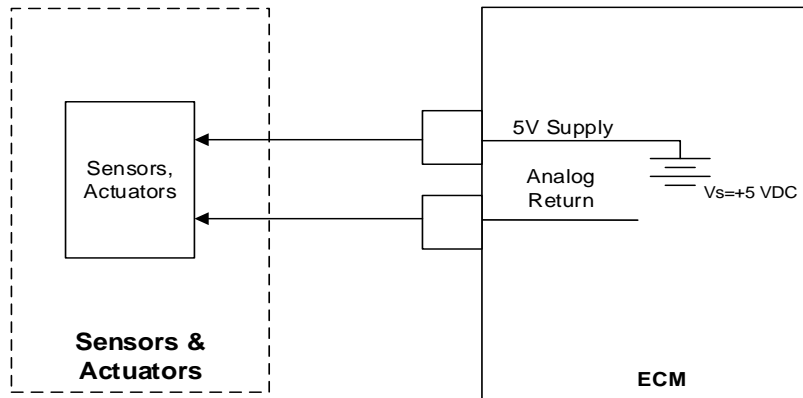

Hardware/Circuit:	External Sensor Supply Voltage Regulator
--------------------------	--

Hardware/Circuit Description:	The external 5-volt supply powers sensors and other components in the engine control system. The accuracy of this supply is critical to the accuracy of the sensors' feed-back, therefore, it is supplied from a precision regulator whose output is internally monitored by the ECM. The ECM monitors the 5-volt supply to ratio metrically correct sensor feedback and determine if the circuit is overloaded, shorted, or otherwise out of specification.
--------------------------------------	--

Possible Causes:	This fault will set if the internally measured voltage feedback of the regulator output is higher than the high voltage limit as defined in the diagnostic calibration anytime the engine is running or stopped at key-on (if applicable).
-------------------------	--

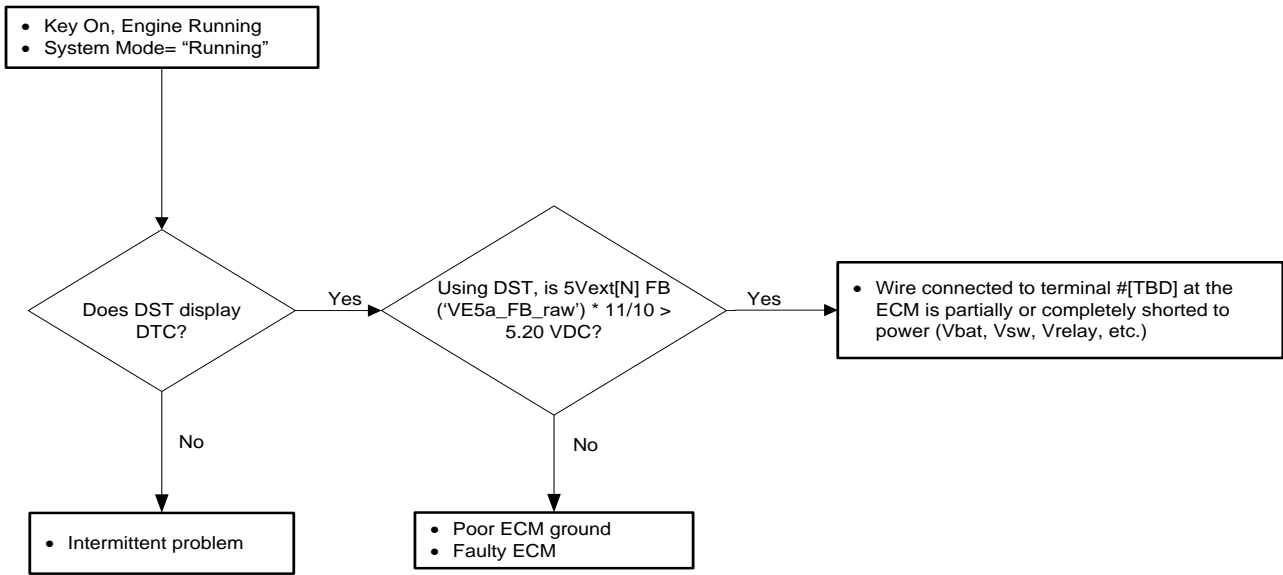

Code			Fault Description
DTC	SPN	FMI	
650	1213	5	MIL Open

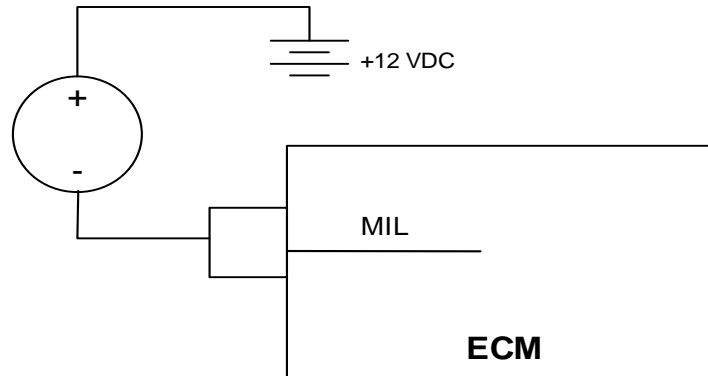

Hardware/Circuit:	Malfunction Indicator Light Circuit
Hardware/Circuit Description:	This ECM output is used to provide a low-side switch to a MIL that is used to indicate that an emission related fault has been set.
Possible Causes:	This fault will set if the ECM detects that there is no load connected to the MIL output.

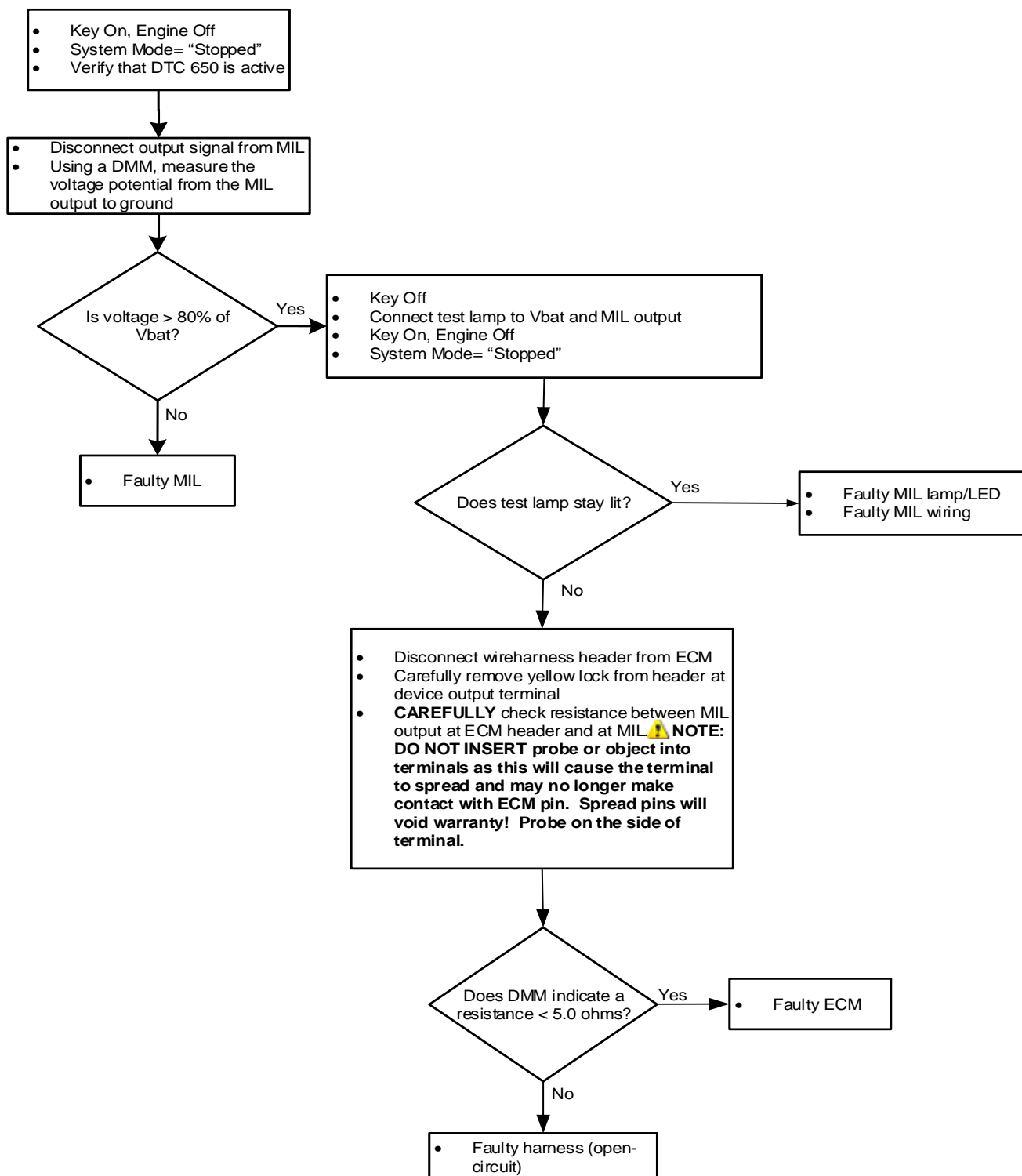

Code			Fault Description
DTC	SPN	FMI	
685	1485	5	Power Relay Coil Open

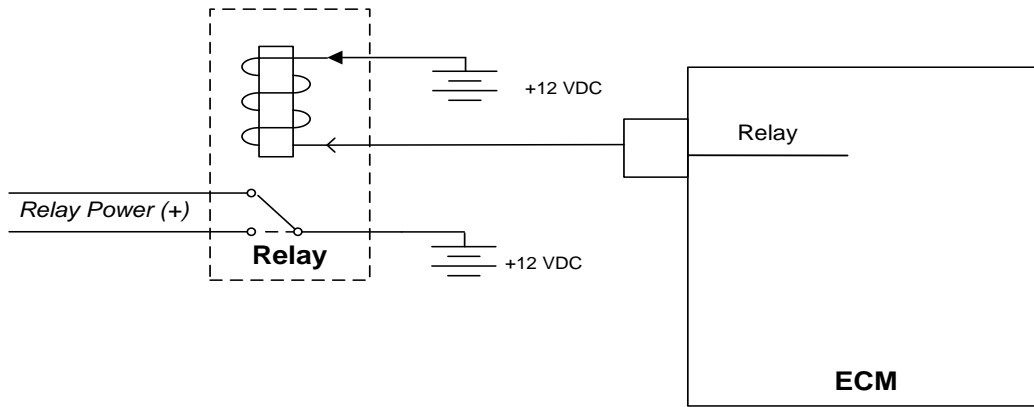

Hardware/Circuit:	Power Relay
--------------------------	-------------

Hardware/Circuit Description:	The ECM has auxiliary low-side drivers that can turn on warning devices or ground electromagnetic relay coils to control power to devices connected to the engine.
--------------------------------------	--

Possible Causes:	This fault sets if the output for the power relay is detected as an open circuit. If this fault is active the relay-powered device(s)(O2 sensor(s), ignition coil(s), injector(s) or similar) will not receive power and the engine likely will not run.
-------------------------	--

DTC 685: Troubleshooting Tree

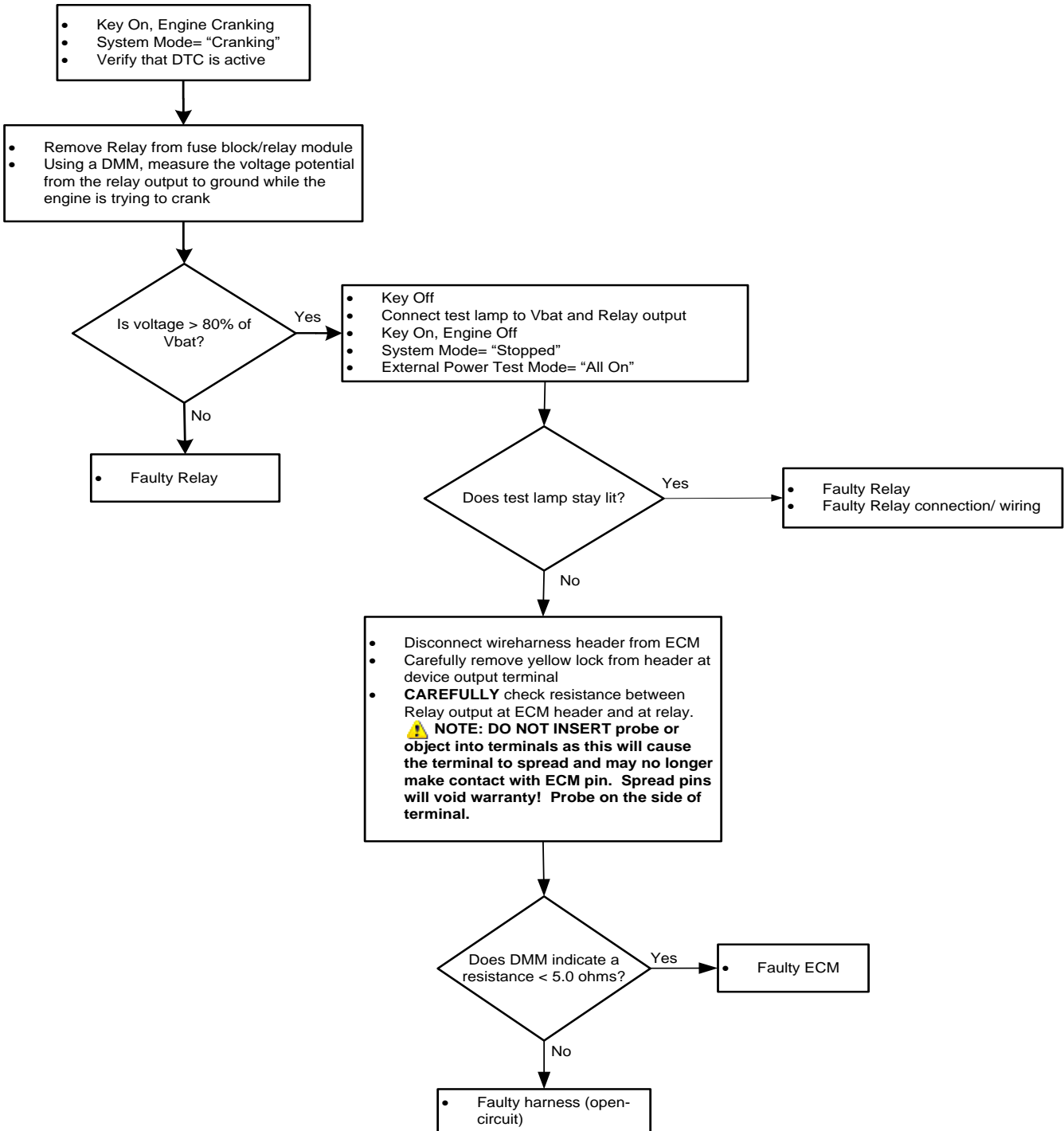

Code			Fault Description
DTC	SPN	FMI	
686	1485	4	Power Relay Coil Ground Short

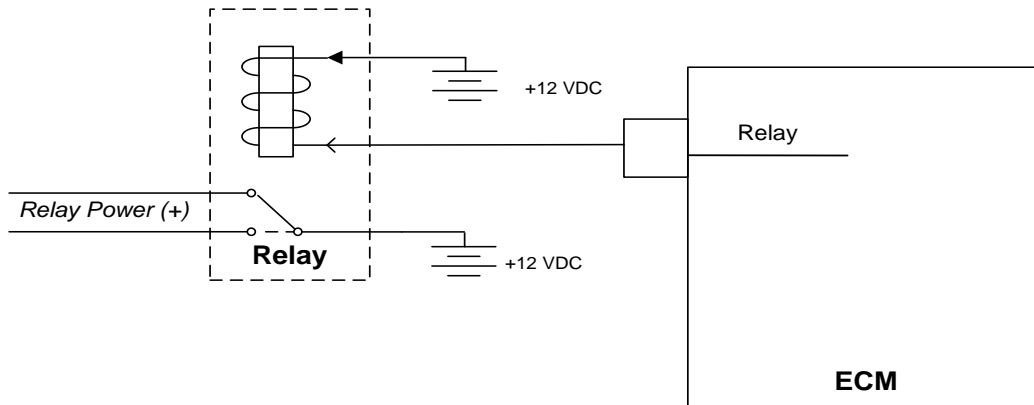

Hardware/Circuit:	Power Relay
--------------------------	-------------

Hardware/Circuit Description:	The ECM has auxiliary low-side drivers that can turn on warning devices or ground electromagnetic relay coils to control power to devices connected to the engine.
--------------------------------------	--

Possible Causes:	This fault sets if the output for the relay is detected as being shorted to ground. If this fault is active and the high-side of the relay is supplied, the relay-powered device(s)(O2 sensor(s), ignition coil(s), injector(s) or similar) will run until the relay or high-side power is removed.
-------------------------	---

NOTE: This fault only applies to certain light-duty and marine platforms using an integrated low-side controller.
--

DTC 686: Troubleshooting Tree

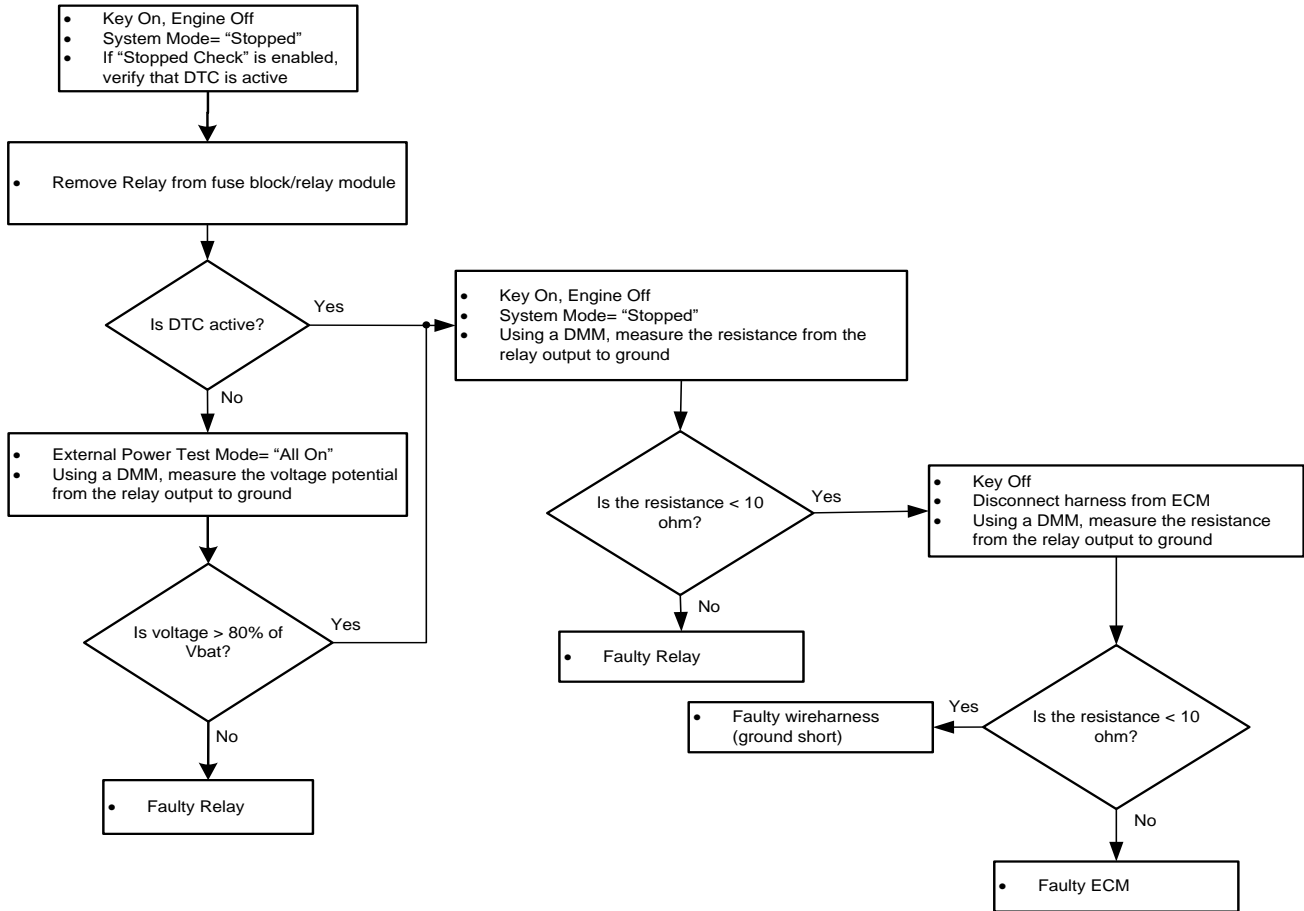

Code			Fault Description
DTC	SPN	FMI	
687	1485	3	Power Relay Coil Short to Power

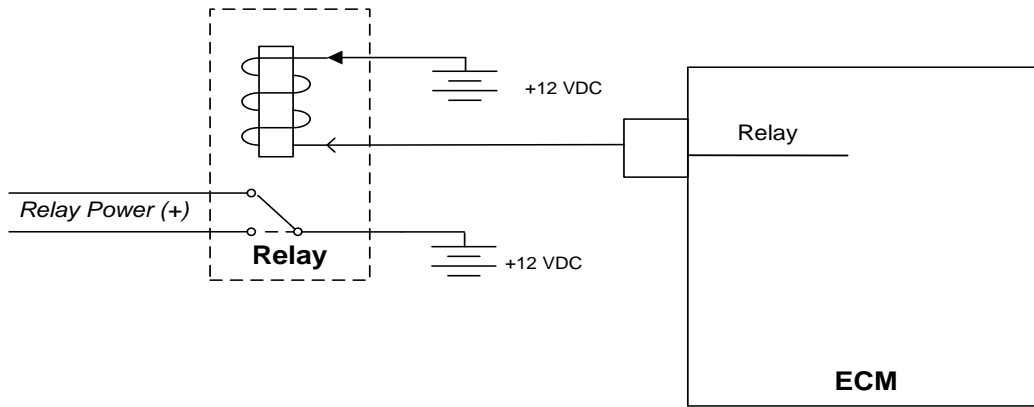

Hardware/Circuit:	Power Relay
--------------------------	-------------

Hardware/Circuit Description:	The ECM has auxiliary low-side drivers that can turn on warning devices or ground electromagnetic relay coils to control power to devices connected to the engine.
--------------------------------------	--

Possible Causes:	This fault sets if the output for the relay is detected as shorted to power. If this fault is active the relay-powered device(s)(O2 sensor(s), ignition coil(s), injector(s) or similar) will not receive power and will not run.
-------------------------	---

DTC 687: Troubleshooting Tree

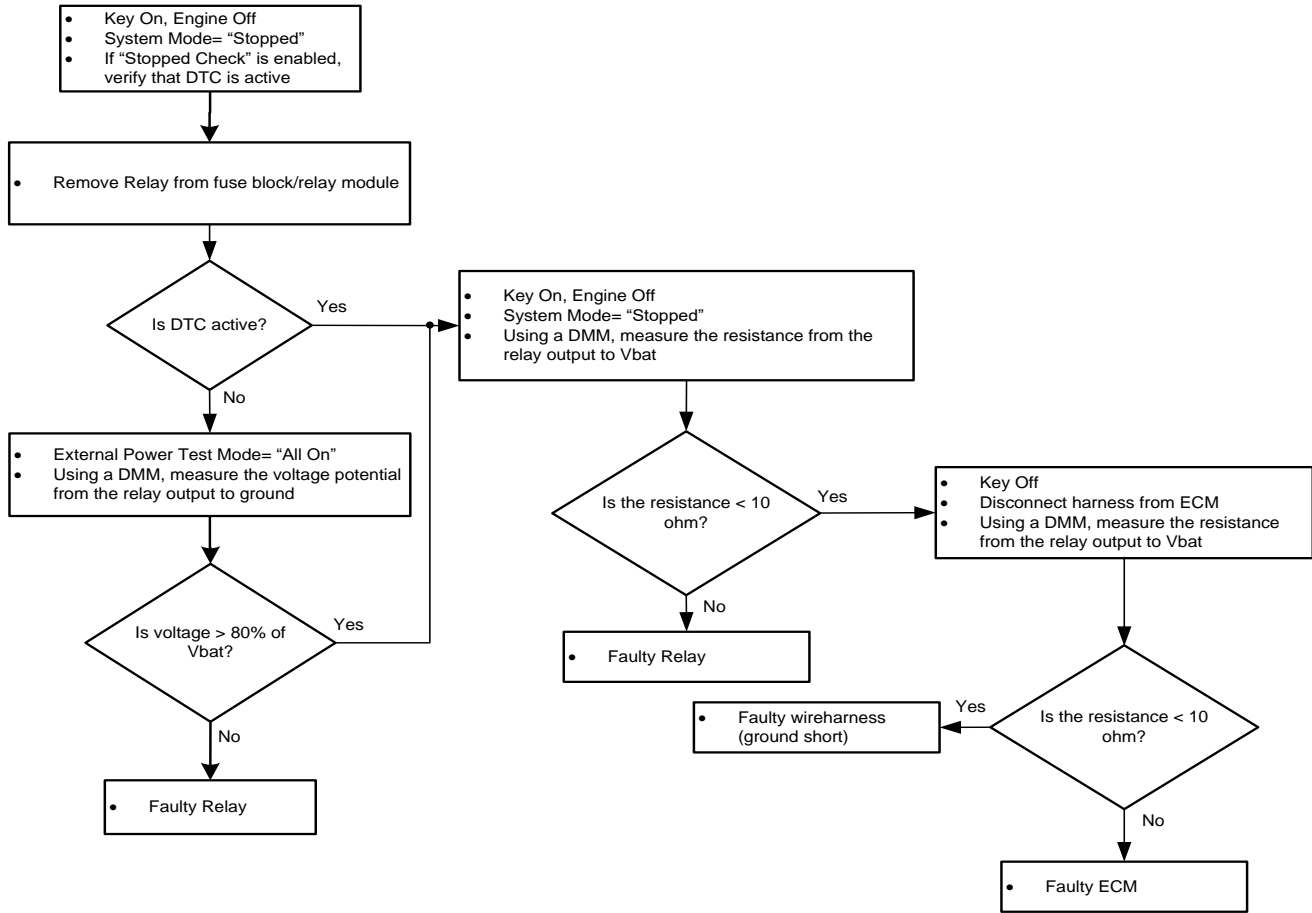

Code			Fault Description
DTC	SPN	FMI	
1068	3563	15	MAP Higher than Expected

Description:	Actual MAP - MAP Estimate > 5.0 psi for more than 2 seconds
---------------------	---

Possible Causes:	<p>Intake air leak</p> <p>MAP holds constant during quick deceleration creating a false positive</p> <p><i>common occurrence during deceleration constant EDI for further diagnostics</i></p> <p style="text-align: right;"><i>if</i></p>
-------------------------	---

Code			Fault Description
DTC	SPN	FMI	
1111	515	16	RPM Above Fuel Rev Limit

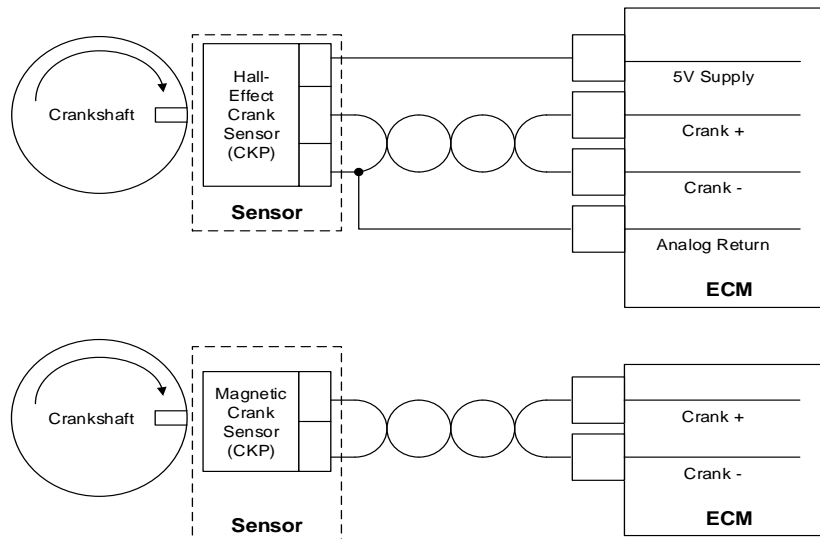

Hardware/Circuit:	Fuel Rev Limit- Crankshaft Position Sensor
--------------------------	--

Hardware/Circuit Description:	This fault is designed to help prevent engine or equipment damage and will disable fuel injectors or gaseous fuel actuator to reduce engine speed. The throttle will also be lowered in order to govern the engine to the speed set in the diagnostic calibration for Max Gov Override.
--------------------------------------	---

Possible Causes:	This fault will set anytime the engine RPM exceeds the limit set in the diagnostic calibration for the latch time or more. This speed overrides any higher max governor speeds programmed by the user.
-------------------------	--

DTC 1111: Diagnostic Aid

NOTE: If any other DTCs are present, diagnose those first.

- Ensure that no programmed governor speeds exceed the limit set in the diagnostic calibration for Max Gov Override Speed
- Check mechanical operation of the throttle
- Check the engine intake for large air leaks downstream of the throttle body

Code			Fault Description
DTC	SPN	FMI	
1112	515	0	RPM Above Spark Rev Limit

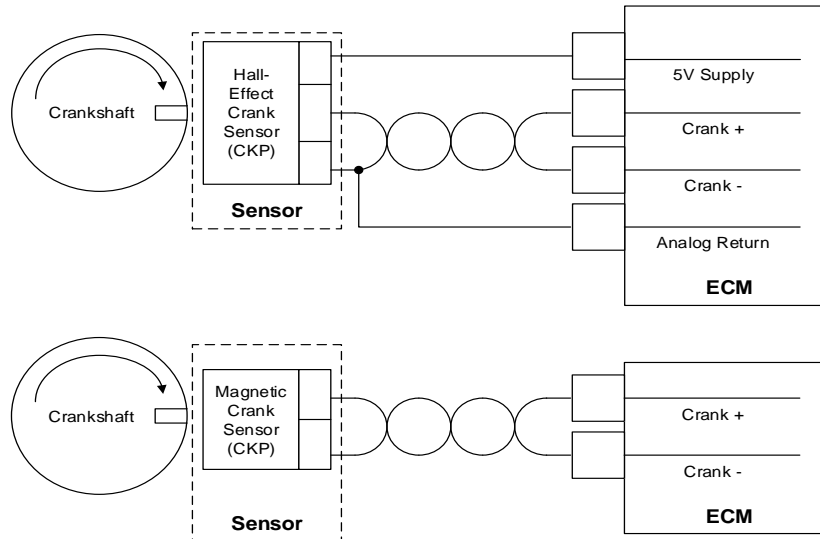

Hardware/Circuit:	Spark Rev Limit- Crankshaft Position Sensor
--------------------------	---

Hardware/Circuit Description:	This fault is designed to help prevent engine or equipment damage and will disable the ignition coils to reduce engine speed. In addition, the throttle will be lowered in order to govern the engine to the speed set in the diagnostic calibration for Max Gov Override, and the fuel injectors or gaseous fuel control actuator will be disabled to reduce the engine speed below the speed set in the diagnostic calibration for Fuel Rev Limit.
--------------------------------------	--

Possible Causes:	This fault will set anytime the engine RPM exceeds the limit set in the diagnostic calibration for the latch time or more. This speed overrides any higher max governor speeds programmed by the user.
-------------------------	--

DTC 1112: Diagnostic Aid

- NOTE: If any other DTCs are present, diagnose those first.
- Ensure that no programmed governor speeds exceed the limit set in the diagnostic calibration for Max Gov Override Speed
 - Check mechanical operation of the throttle
- Check the engine intake for large air leaks downstream of the throttle body

Code			Fault Description
DTC	SPN	FMI	
1121	91	31	FPP1/FPP2 SIMULTANEOUS VOLTAGES OUT OF RANGE

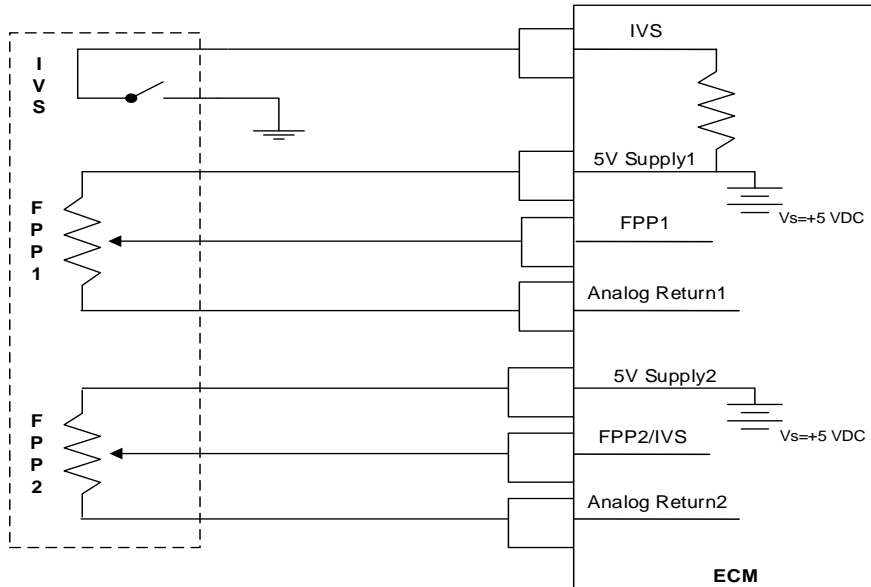

Hardware/Circuit:	Electronic foot pedal/throttle control sensor
--------------------------	---

Hardware/Circuit Description:	<p>The FPP sensor is an electronic device that is coupled to a mechanically driven input as commanded by the vehicle/engine operator. A FPP sensor may be, but is not limited to a foot pedal assembly, a cable-lever-sensor assembly, or a rotary potentiometer. General sensor configurations consist of single potentiometer with IVS, two potentiometers, or two potentiometers with IVS. The FPP sensor outputs are proportional to the commanded input. The ECM uses the FPP sensor inputs to control the throttle and adjust the engine's load in order to achieve the requested power. Since the FPP sensor inputs directly affect the engine's power output, redundant sensors are generally used to ensure safe, reliable operation.</p>
--------------------------------------	--

Possible Causes:	This fault is only applicable with sensors that incorporate dual potentiometer and indicates that FPP1 and FPP2 voltages are out-of-range resulting in a loss of redundancy. As a result, the engine is commanded to a forced idle.
-------------------------	---

DTC 1121: Diagnostic Aid

<p>Diagnostic Aids</p> <ul style="list-style-type: none"> <input type="checkbox"/> Troubleshoot according to <i>FPP1 voltage out-of-range</i> following DTC 2122 and 2123 procedures. <input type="checkbox"/> Troubleshoot according to <i>FPP2 voltage out-of-range</i> following DTC 2127 and 2128 procedures.
--

Code			Fault Description
DTC	SPN	FMI	
1122	520199	11	FPP1/FPP2 Do Not Match Each Other or the IVS

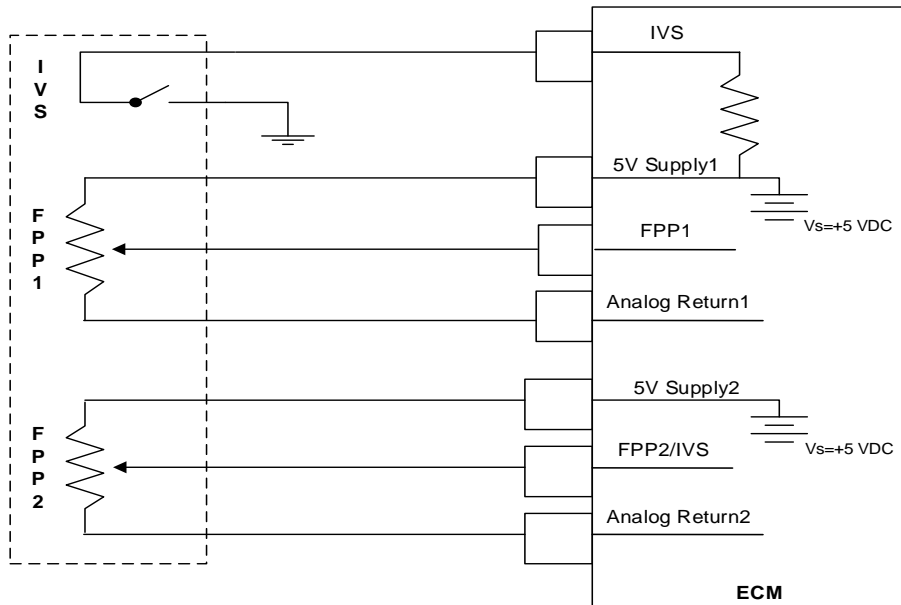

Hardware/Circuit:	Electronic foot pedal/throttle control sensor
--------------------------	---

Hardware/Circuit Description:	<p>The FPP sensor is an electronic device that is coupled to a mechanically driven input as commanded by the vehicle/engine operator. A FPP sensor may be, but is not limited to a foot pedal assembly, a cable-lever-sensor assembly, or a rotary potentiometer. General sensor configurations consist of single potentiometer with IVS, two potentiometers, or two potentiometers with IVS. The FPP sensor outputs are proportional to the commanded input. The ECM uses the FPP sensor inputs to control the throttle and adjust the engine's load in order to achieve the requested power. Since the FPP sensor inputs directly affect the engine's power output, redundant sensors are generally used to ensure safe, reliable operation.</p>
--------------------------------------	--

Possible Causes:	<p>This fault is only applicable for dual potentiometer/single IVS sensors and indicates that FPP1 and FPP2 percentages do not correlate with each other and neither of the two potentiometers correlates with the IVS.</p>
-------------------------	---

DTC 1122: Diagnostic Aid

- Troubleshoot according to *FPP1 & FPP2 Do Not Match* following DTC 2121 and 2126 procedures.
- Troubleshoot according to *FPP1 & FPP2 Do Not Match IVS* following DTC 2115, 2116, 2139, and 2140 procedures.

Code			Fault Description
DTC	SPN	FMI	
1151	4236	0	Closed Loop High LPG
1153	4236	0	Closed Loop High NG
1155	4236	0	Closed Loop High Gasoline (Bank 1)
1157	4236	0	Closed Loop High Gasoline (Bank 2)

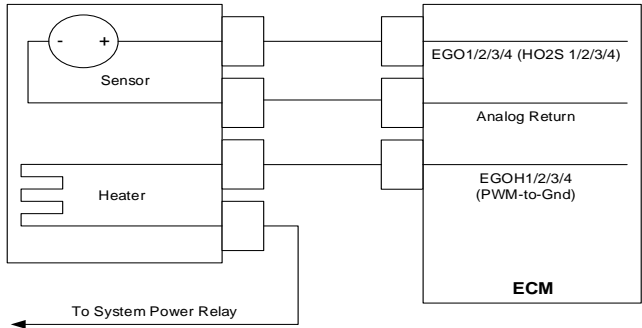

Hardware/Circuit:	Heated or Universal Exhaust Gas Oxygen Sensor (Bank 1-Sensor 1/Bank 1-Before Catalyst)
--------------------------	---

Hardware/Circuit Description:	<p>The HEGO/HO2S sensor is a switching-type sensor around stoichiometry that measures the oxygen content present in the exhaust to determine if the fuel flow to the engine is correct. A UEGO sensor measures the exhaust content across a wide-range of air-fuel ratios with a linear output proportional to lambda/equivalence ratio/air-fuel ratio. In either case, if there is a deviation between the expected reading and the actual reading, fuel flow is precisely adjusted for each bank using the Closed Loop multiplier and then “learned” with the Adaptive multiplier. The multipliers only update when the system is in either “CL Active” or “CL + Adapt” control modes. The purpose of the closed loop fuel multiplier is to quickly adjust fuel flow due to variations in fuel composition; engine wear, engine-to-engine build variances, and component degradation prior to adaptive learn fueling correction “learning” the fueling deviation.</p>
--------------------------------------	---

Possible Causes:	<p>This fault sets if the Closed Loop multiplier exceeds the high limit of normal operation indicating that the engine is operating lean (excess oxygen) and requires more fuel than allowed by corrections. Often high positive fueling corrections are a function of one or more of the following conditions: 1) exhaust leaks upstream or near the HEGO sensor, 2) reduced fuel supply pressure to the gaseous fuel control system, 3) a fuel supply or manifold leak, 4) a non-responsive HEGO/UEGO sensor, and/or 5) a defective gaseous fuel control component (actuator/valve and/or mixer). This fault should be configured to disable adaptive learn for the remainder of the key-cycle to avoid improperly learning the adaptive learn table and may be configured to disable closed loop.</p>
-------------------------	--

DTC 1151 - 1153 - 1155 - 1157: Diagnostic Aid

NOTE: If any other DTCs are present, diagnose those first.

- Oxygen Sensor Wire - Sensor may be mispositioned contacting the exhaust. Check for short to ground between harness and sensor sense signal.
- Vacuum Leaks - Large vacuum leaks and crankcase leaks can cause a lean exhaust condition at light load.
- Fuel Pressure - System will be lean if fuel pressure is too low. Ensure fuel tank pressure is not too low and that gaseous fuel control actuator/regulator has proper fuel pressure under all operating conditions.
- Exhaust Leaks - If there is an exhaust leak, outside air can be pulled into the exhaust and past the O2 sensor causing a false lean condition.
- Fuel Quality - A drastic variation in fuel quality may cause the system to be lean including fuels with high inert gas content.
- System Grounding - ECM and engine must be grounded to the battery with very little resistance allowing for proper current flow. Faulty grounds can cause current supply issues resulting in many undesired problems.
- Injectors (Injected fuel applications only) - System will be lean if an injector driver or driver circuit fails. The system will also be lean if an injector fails in a closed manner or is dirty.
- Air in Fuel (Gasoline applications only) - If the fuel return hose/line is too close to the fuel supply pickup in the fuel tank, air may become entrapped in the pump or supply line causing a lean condition and driveability problems.

If all tests are OK, replace the HO2S or UEGO sensor with a known good part and retest

Code			Fault Description
DTC	SPN	FMI	
1152	4236	1	Closed Loop Low LPG
1154	4236	1	Closed Loop Low NG
1156	4236	1	Closed Loop Low Gasoline (Bank 1)
1158	4236	1	Closed Loop Low Gasoline (Bank 2)

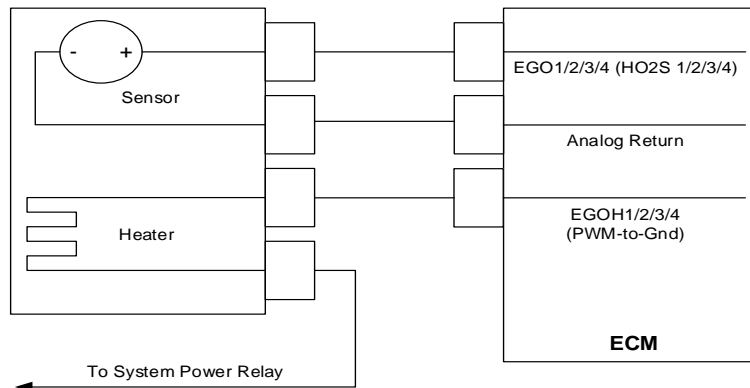

Hardware/Circuit:	Heated or Universal Exhaust Gas Oxygen Sensor (Bank 1-Sensor 1/Bank 1-Before Catalyst)
--------------------------	---

Hardware/Circuit Description:	<p>The HEGO/HO2S sensor is a switching-type sensor around stoichiometry that measures the oxygen content present in the exhaust to determine if the fuel flow to the engine is correct. A UEGO sensor measures the exhaust content across a wide-range of air-fuel ratios with a linear output proportional to lambda/equivalence ratio/air-fuel ratio. In either case, if there is a deviation between the expected reading and the actual reading, fuel flow is precisely adjusted for each bank using the Closed Loop multiplier and then “learned” with the Adaptive multiplier. The multipliers only update when the system is in either “CL Active” or “CL + Adapt” control modes. The purpose of the closed loop fuel multiplier is to quickly adjust fuel flow due to variations in fuel composition; engine wear, engine-to-engine build variances, and component degradation prior to adaptive learn fueling correction “learning” the fueling deviation.</p>
--------------------------------------	---

Possible Causes:	<p>This fault sets if the Closed Loop multiplier exceeds the low limit of normal operation indicating that the engine is operating rich (excess fuel) and requires less fuel than allowed by corrections. Often high negative fueling corrections are a function of one or more of the following conditions: 1) high fuel supply pressure to the gaseous fuel control or faulty pressure regulator and/or 2) a non-responsive HEGO/UEGO sensor. This fault should be configured to disable adaptive learn for the remainder of the key-cycle to avoid improperly learning the adaptive learn table and may be configured to disable closed loop.</p>
-------------------------	--

DTC 1152 - 1154 - 1156 - 1158: Diagnostic Aid

NOTE: If any other DTCs are present, diagnose those first.

- Oxygen Sensor Wire - Sensor may be mispositioned contacting the exhaust. Check for short to ground between harness and sensor and on sensor harness
- Fuel Pressure - System will be rich if fuel delivery pressure is too high to gaseous control system. Check fuel pressure at the control actuator/valve under all operating conditions.
- System Grounding - ECM and engine must be grounded to the battery with very little resistance allowing for proper current flow. Faulty grounds can cause current supply issues resulting in many undesired problems.
- Injectors (Injected fuel applications only) - System will be rich if an injector driver or driver circuit fails shorted-to-ground. The system will also be rich if an injector fails in an open.

If all tests are OK, replace the HO2S or UEGO sensor with a known good part and retest.

Code			Fault Description
DTC	SPN	FMI	
1161	4237	0	Adaptive Lean High LPG
1163	4237	0	Adaptive Lean High NG

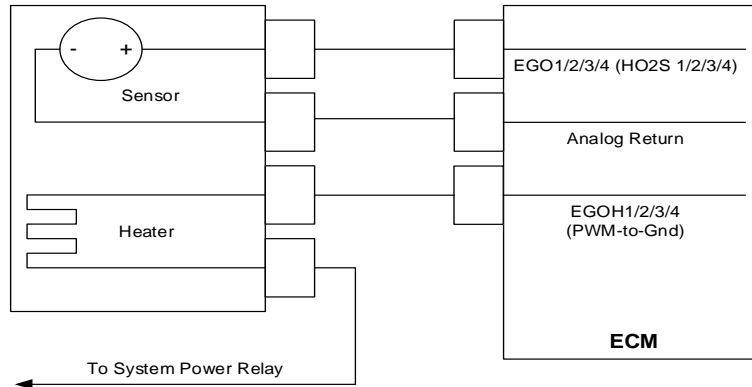

Hardware/Circuit:	Heated or Universal Exhaust Gas Oxygen Sensor (Bank 1-Sensor 1/Bank 1-Before Catalyst)
--------------------------	---

Hardware/Circuit Description:	<p>The HEGO/HO2S sensor is a switching-type sensor around stoichiometry that measures the oxygen content present in the exhaust to determine if the fuel flow to the engine is correct. A UEGO sensor measures the exhaust content across a wide-range of air-fuel ratios with a linear output proportional to lambda/equivalence ratio/air-fuel ratio. In either case, if there is a deviation between the expected reading and the actual reading, fuel flow is precisely adjusted for each bank using the Closed Loop multiplier and then “learned” with the Adaptive multiplier. The multipliers only update when the system is in either “CL Active” or “CL + Adapt” control modes. The purpose of the Adaptive Learn fuel multiplier is to adjust fuel flow due to variations in fuel composition, engine wear, engine-to-engine build variances, and component degradation.</p>
--------------------------------------	--

Possible Causes:	<p>This fault sets if the Adaptive multiplier exceeds the high limit of normal operation indicating that the engine is operating lean (excess oxygen) and requires more fuel than allowed by corrections. Often high positive fueling corrections are a function of one or more of the following conditions: 1) exhaust leaks upstream or near the HEGO sensor, 2) reduced fuel supply pressure to the gaseous fuel control system, 3) a fuel supply or manifold leak, 4) a non-responsive HEGO/UEGO sensor, and/or 5) a defective gaseous fuel control component (actuator/valve and/or mixer). This fault should be configured to disable adaptive learn for the remainder of the key-cycle to avoid improperly learning the adaptive learn table and may be configured to disable closed loop.</p>
-------------------------	---

DTC 1161-1163: Diagnostic Aid

NOTE: If any other DTCs are present, diagnose those first.

- Oxygen Sensor Wire - Sensor may be mispositioned contacting the exhaust. Check for short to ground between harness and sensor sense signal.
- Vacuum Leaks - Large vacuum leaks and crankcase leaks can cause a lean exhaust condition at light load.
- Fuel Pressure - System will be lean if fuel pressure is too low. Ensure fuel tank pressure is not too low and that gaseous fuel control actuator/regulator has proper fuel pressure under all operating conditions.
- Exhaust Leaks - If there is an exhaust leak, outside air can be pulled into the exhaust and past the O2 sensor causing a false lean condition.
- Fuel Quality - A drastic variation in fuel quality may cause the system to be lean including fuels with high inert gas content.
- System Grounding - ECM and engine must be grounded to the battery with very little resistance allowing for proper current flow. Faulty grounds can cause current supply issues resulting in many undesired problems.

If all tests are OK, replace the HO2S or UEGO sensor with a known good part and retest.

Code			Fault Description
DTC	SPN	FMI	
1162	4237	1	Adaptive Lean Low LPG
1164	4237	1	Adaptive Lean Low NG

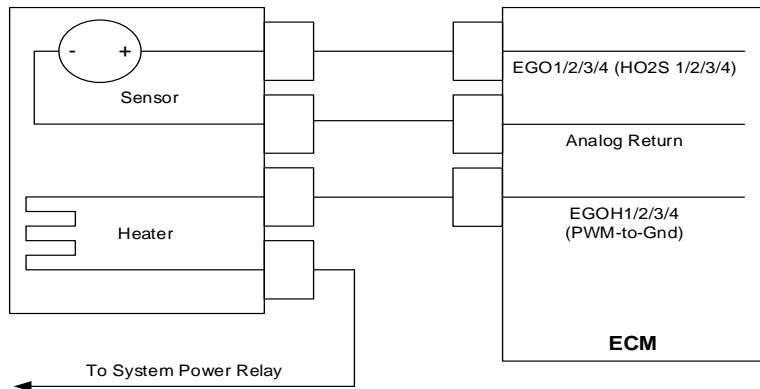

Hardware/Circuit:	Heated or Universal Exhaust Gas Oxygen Sensor (Bank 1-Sensor 1/Bank 1-Before Catalyst)
--------------------------	---

Hardware/Circuit Description:	<p>The HEGO/HO2S sensor is a switching-type sensor around stoichiometry that measures the oxygen content present in the exhaust to determine if the fuel flow to the engine is correct. A UEGO sensor measures the exhaust content across a wide-range of air-fuel ratios with a linear output proportional to lambda/equivalence ratio/air-fuel ratio. In either case, if there is a deviation between the expected reading and the actual reading, fuel flow is precisely adjusted for each bank using the Closed Loop multiplier and then “learned” with the Adaptive multiplier. The multipliers only update when the system is in either “CL Active” or “CL + Adapt” control modes. The purpose of the Adaptive Learn fuel multiplier is to adjust fuel flow due to variations in fuel composition, engine wear, engine-to-engine build variances, and component degradation.</p>
--------------------------------------	--

Possible Causes:	<p>This fault sets if the Adaptive multiplier exceeds the low limit of normal operation indicating that the engine is operating rich (excess fuel) and requires less fuel than allowed by corrections. Often high negative fueling corrections are a function of one or more of the following conditions: 1) high fuel supply pressure to the gaseous fuel control or faulty pressure regulator and/or 2) a non-responsive HEGO/UEGO sensor. This fault should be configured to disable adaptive learn for the remainder of the key-cycle to avoid improperly learning the adaptive learn table and may be configured to disable closed loop.</p>
-------------------------	---

DTC 1162-1164: Diagnostic Aid

NOTE: If any other DTCs are present, diagnose those first.

- Oxygen Sensor Wire - Sensor may be mispositioned contacting the exhaust. Check for short to ground between harness and sensor and on sensor harness
- Fuel Pressure - System will be rich if fuel delivery pressure is too high to gaseous control system. Check fuel pressure at the control actuator/valve under all operating conditions.
- System Grounding - ECM and engine must be grounded to the battery with very little resistance allowing for proper current flow. Faulty grounds can cause current supply issues resulting in many undesired problems.

If all tests are OK, replace the HO2S or UEGO sensor with a known good part and retest.

Code			Fault Description
DTC	SPN	FMI	
1165	3050	11	Catalyst Inactive LPG
1166	3050	11	Catalyst Inactive NG

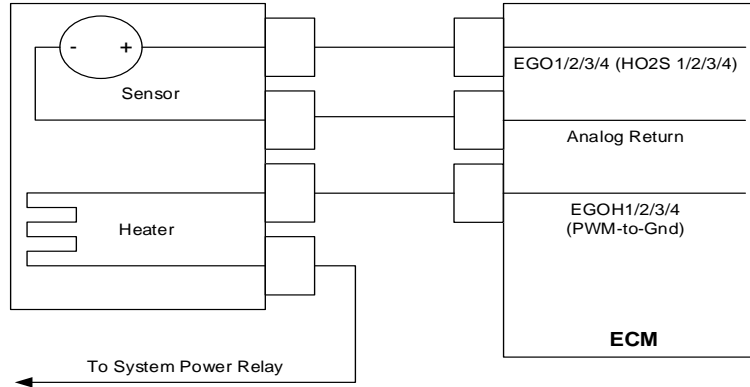

Hardware/Circuit:	Heated or Universal Exhaust Gas Oxygen Sensor (Bank 1-Sensor 1/Bank 1-Before Catalyst)
--------------------------	---

Hardware/Circuit Description:	<p>A catalyst or catalytic converter is used to accelerate/generate chemical reactions within the engine exhaust to convert undesirable gases/pollutants into less harmful gases. In many spark-ignited applications, a three-way catalyst is used to convert hydrocarbons, oxides of nitrogen, and carbon monoxide into nitrogen, water, and carbon dioxide. In addition, many low-emission applications require the use of OBD, which typically require a catalyst monitor to confirm proper catalyst function. The catalyst monitor diagnostic is typically configured such that exhaust emissions are near compliance-failing levels based on the engines specific regulatory requirement(s). Catalyst monitor techniques typically utilize a HEGO sensor to monitor the amount of oxygen present downstream of the catalyst. This is a good indicator of how efficiently the catalyst is using the oxygen entering the catalyst. Some systems also use temperature measurements in the catalyst and compare it to data stored in the ECM for each operating condition to determine if the catalytic reaction is generating the proper amount of heat.</p> <p>The HEGO/HO2S is a switching-type sensor around stoichiometry that measures the oxygen content downstream of the catalyst for two main functions: 1) to compare it to the oxygen content upstream of the catalyst to determine how efficiently the catalyst is using oxygen to determine its effectiveness and 2) trim the commanded equivalence ratio target to maximize the catalyst conversion efficiency. The post-catalyst strategy and diagnostic is only active when the system is in either "CL Active" or "CL + Adapt" control modes.</p>
--------------------------------------	--

Possible Causes:

In theory if the catalyst is operated at a condition that could result in 100 percent conversion efficiency, the catalyst will use all available oxygen present in the exhaust gas to convert the emission pollutants (or reactants) to N₂, CO₂, and H₂O. However, since catalysts generally operate at efficiencies between 85-95% post-catalyst oxygen concentration can be a direct indicator of how efficient the catalyst is. The figure below shows an example of a slightly rich biased feed gas or pre-catalyst equivalence ratio versus that of the post-catalyst for a functional catalyst.

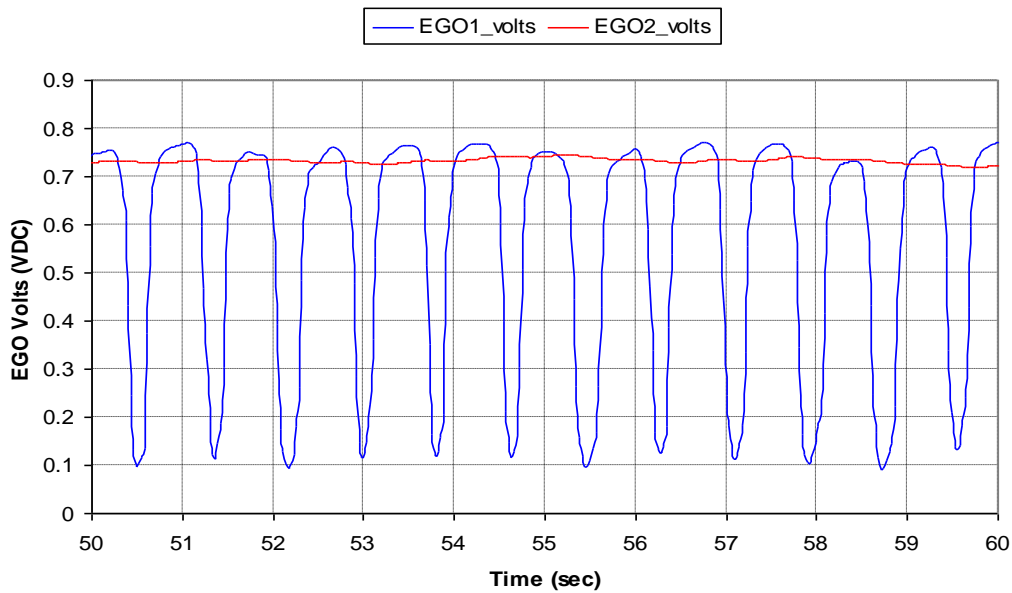

EGO Waveforms (Functional TWC)

It can be noticed from this figure that the pre-catalyst equivalence ratio, as identified by 'EGO1_volts', is varying due to the CL excursions (perturbation) and that the post-catalyst equivalence ratio, as identified by 'EGO2_volts', is maintained relatively constant rich of stoichiometry. A similar waveform pattern should be expected on properly functioning catalysts.

The figure below shows an example of EGO waveforms for a catalyst with poor conversion efficiency.

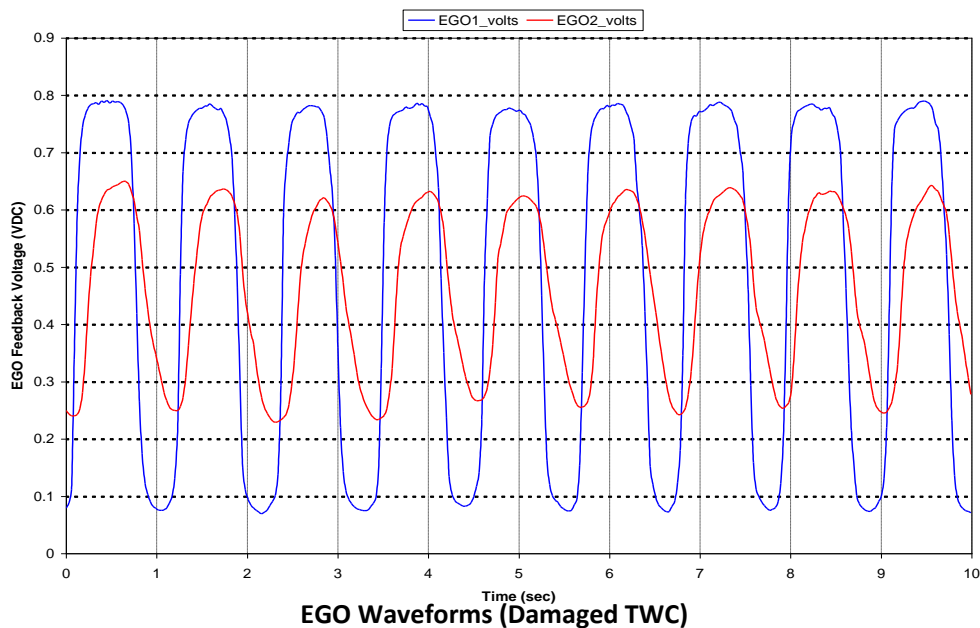

A significant difference between the two EGO waveforms in the images above is that the post-catalyst EGO feedback related to the damaged TWC oscillates with the same frequency as the pre-catalyst EGO feedback and the amplitude is on the order of 60% of that of EGO1. This indicates that a certain amount of oxygen that is entering into the catalyst is passing through the catalyst unconsumed. Catalyst monitor diagnostics are configured such that if the post-catalyst EGO waveform has an amplitude that is directly proportional to the pre-catalyst EGO waveform and who's waveform similarly matches the closed-loop excursion (perturbation) a fault is generated.

Two metric comparisons that are used to identify the health of the catalyst are:

- 1) Post-catalyst EGO root-mean square (RMS) > Pre-catalyst EGO RMS x [TBD]%, where the [TBD]% is determined based on emissions compliance testing over the application's certified duty-cycle(s).
- 2) Post-catalyst EGO RMS > CL excursion RMS x [TBD]%, where the [TBD]% is determined based on emissions compliance testing over the application's certified duty-cycle(s).

There are a couple of ways in which the limits for diagnostics can be determined. In both cases, the system must be tested with an emissions measurement system to determine when the exhaust emissions are nearly failing emissions compliance.

Diagnostic Aids

NOTE: If any other DTCs are present, diagnose those first.

- Exhaust Leak – Pressurize exhaust system with 1-2 psig of air and check for pressure leaks upstream and around catalyst and post-catalyst HEGO sensor. Replace gaskets and tighten fasteners if leaks are present.

Perform manufacture recommended in-field emissions test.

Code			Fault Description
DTC	SPN	FMI	
1171	520260	0	DEPR (MJ) Delivery Pressure Higher Than Expected

Hardware/Circuit Description:	<p>The EPR is the second generation of EControls' Electronic Pressure Regulator found in many industrial and heavy-duty applications. The 2nd generation EPR is a "smart" actuator integrated with the primary stage regulator designed to control gaseous fuel pressure in the secondary stage regulator. The EPR receives fuel pressure commands from the ECM and quickly and precisely modulates fuel pressure to the gaseous fuel mixer. The EPR allows for fast and accurate gaseous fuel control to provide a combustible mixture to the engine.</p> <p>The third generation of EControls' Electronic Pressure Regulator is the DEPR. The DEPR is a "smart" actuator that is fed supply pressure through a DSR (Dual Stage Regulator). The DSR is fully mechanical. The DEPR receives fuel pressure commands from the ECM and quickly and precisely modulates fuel pressure to the gaseous fuel mixer. The DEPR allows for very fast and very accurate gaseous fuel control to provide a combustible mixture to the engine</p> <p>The fourth generation of EControls' gaseous fuel control valve is the CFV. The CFV contains both a high-pressure Electronic Pressure Regulator and a precision Continuous Flow Valve. The inlet pressure to the CFV is typically 85 psig (586 kPa). The CFV receives mass flow commands from the ECM and quickly and precisely modulates both the fuel pressure and metering valve to achieve the desired mass flow. The CFV allows for very fast and very accurate gaseous fuel control to provide a combustible mixture to the engine.</p>
--------------------------------------	--

Possible Causes:	<p>This fault sets if the actual pressure sensed in the EPR/CFV is greater than the commanded pressure by X. Typical values for X are listed below (may vary per specific engine calibration):</p> <p>X = + 2.0 in H2O for EPR (HD EPR or DEPR) X = + 10 psi (69 kPa) for CFV</p> <p>This fault indicates that the device is at its minimum limit of authority and the pressure command cannot be achieved likely due to delivery/supply pressure being higher than expected. Adaptive fueling correction is disabled to avoid improper learning of the fuel correction table due to improper fuel supply pressure, and a Power Derate 1 condition is activated to reduce the possibility of engine damage.</p>
-------------------------	--

DTC 1171: Troubleshooting Tree

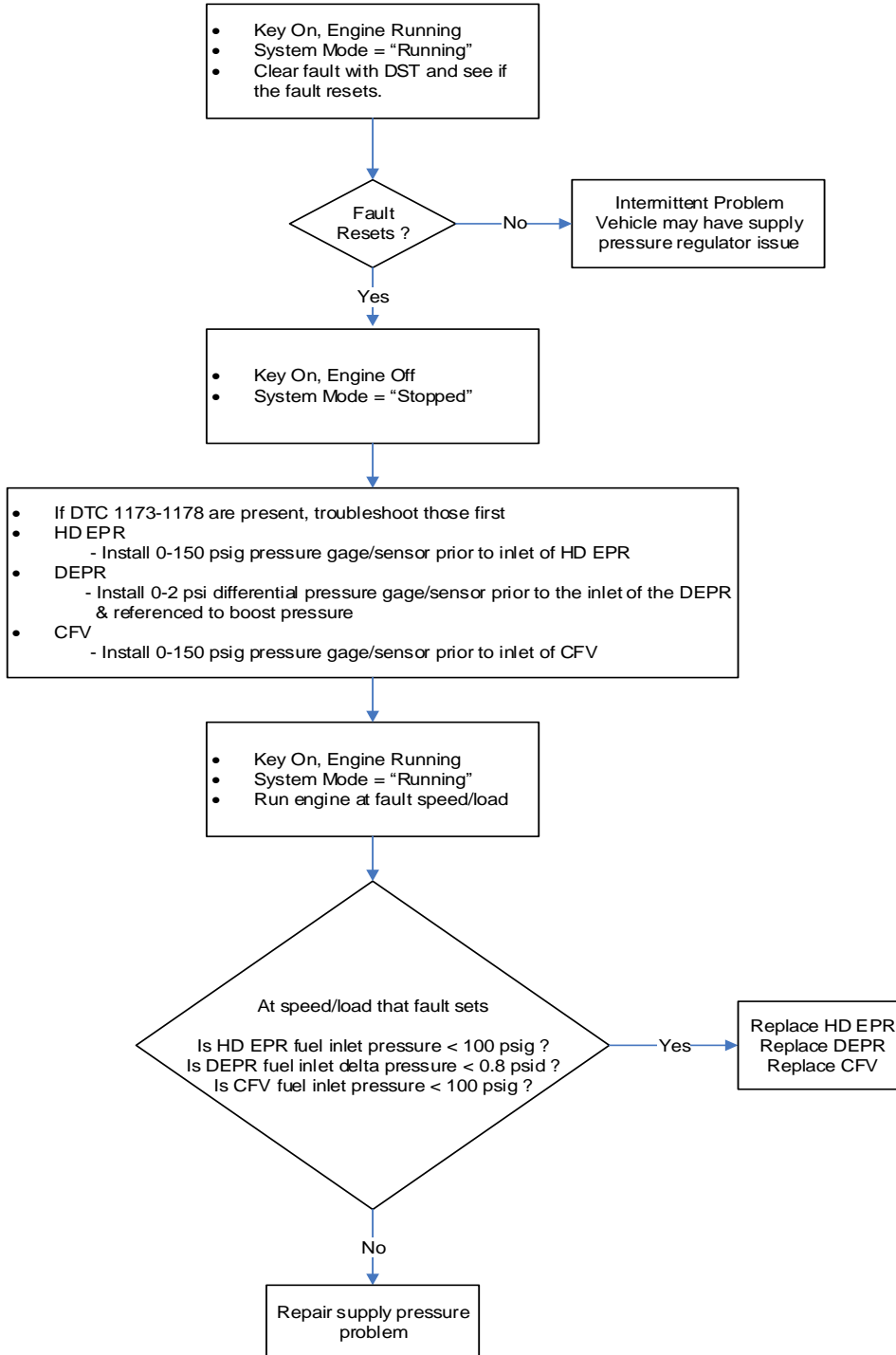

Code			Fault Description
DTC	SPN	FMI	
1172	520260	1	DEPR (MJ) Delivery Pressure Lower Than Expected

Hardware/Circuit Description:	<p>The EPR is the second generation of EControls' Electronic Pressure Regulator found in many industrial and heavy-duty applications. The 2nd generation EPR is a "smart" actuator integrated with the primary stage regulator designed to control gaseous fuel pressure in the secondary stage regulator. The EPR receives fuel pressure commands from the ECM and quickly and precisely modulates fuel pressure to the gaseous fuel mixer. The EPR allows for fast and accurate gaseous fuel control to provide a combustible mixture to the engine.</p> <p>The third generation of EControls' Electronic Pressure Regulator is the DEPR. The DEPR is a "smart" actuator that is fed supply pressure through a DSR (Dual Stage Regulator). The DSR is fully mechanical. The DEPR receives fuel pressure commands from the ECM and quickly and precisely modulates fuel pressure to the gaseous fuel mixer. The DEPR allows for very fast and very accurate gaseous fuel control to provide a combustible mixture to the engine.</p> <p>The fourth generation of EControls' gaseous fuel control valve is the CFV. The CFV contains both a high-pressure Electronic Pressure Regulator and a precision Continuous Flow Valve. The inlet pressure to the CFV is typically 85 psig (586 kPa). The CFV receives mass flow commands from the ECM and quickly and precisely modulates both the fuel pressure and metering valve to achieve the desired mass flow. The CFV allows for very fast and very accurate gaseous fuel control to provide a combustible mixture to the engine.</p>
--------------------------------------	---

Possible Causes:	<p>This fault sets if the actual pressure sensed in the EPR/CFV is lower than the commanded pressure by X. Typical values for X are listed below (may vary per specific engine calibration):</p> <p>X = - 2.0 in H₂O for EPR (HD EPR or DEPR) X = - 10 psi (69 kPa) for CFV</p> <p>This fault indicates that the device is at its maximum limit of authority and the pressure command cannot be achieved likely due to delivery/supply pressure being higher than expected. Adaptive fueling correction is disabled to avoid improper learning of the fuel correction table due to improper fuel supply pressure, and a Power Derate 1 condition is activated to reduce the possibility of engine damage.</p>
-------------------------	---

DTC 1172: Troubleshooting Tree

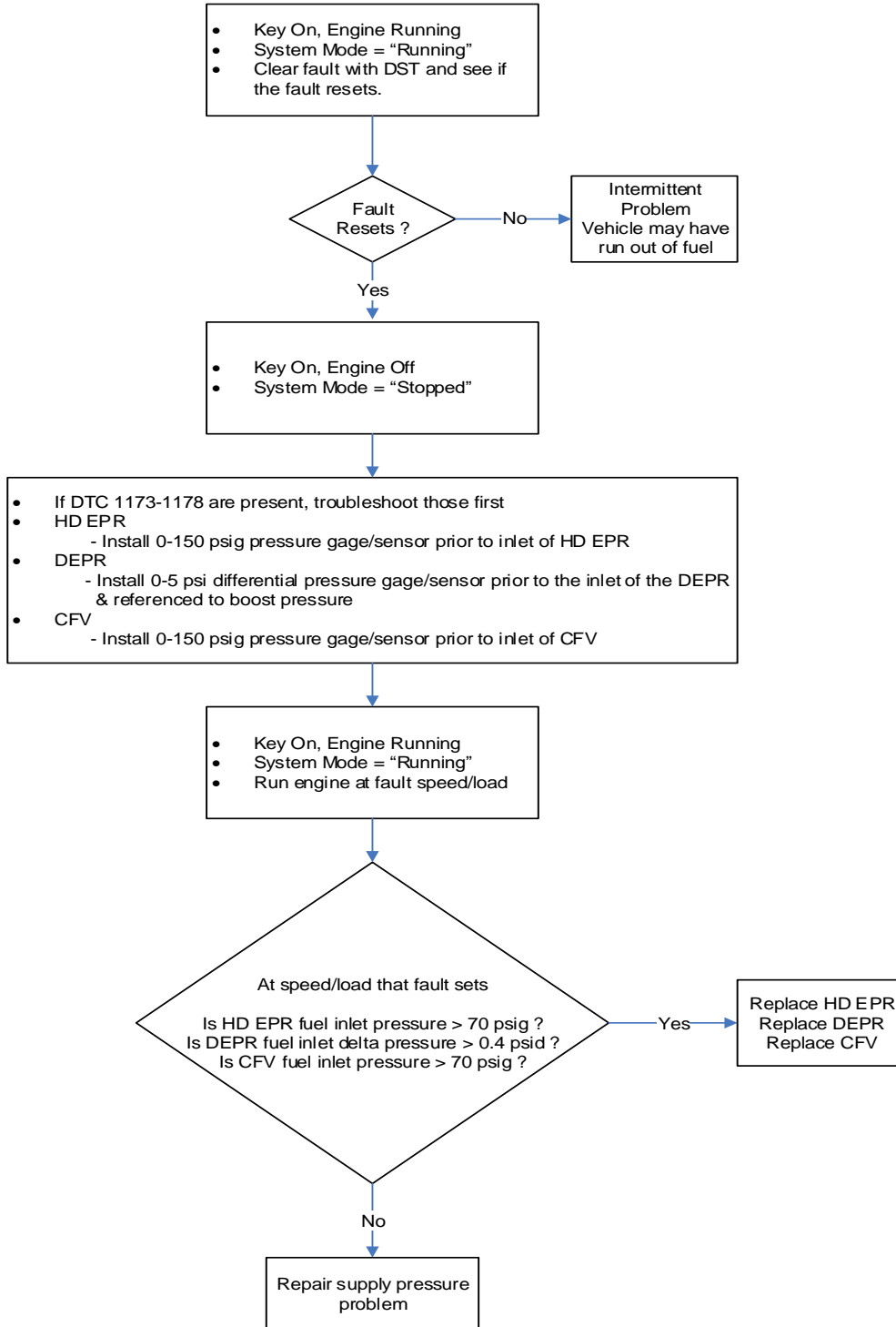

Code			Fault Description
DTC	SPN	FMI	
1173	520260	31	DEPR (MJ) Communication Loss

Hardware/Circuit Description:	<p>The EPR is the second generation of EControls' Electronic Pressure Regulator found in many industrial and heavy-duty applications. The 2nd generation EPR is a "smart" actuator integrated with the primary stage regulator designed to control gaseous fuel pressure in the secondary stage regulator. The EPR receives fuel pressure commands from the ECM and quickly and precisely modulates fuel pressure to the gaseous fuel mixer. The EPR allows for fast and accurate gaseous fuel control to provide a combustible mixture to the engine.</p> <p>The third generation of EControls' Electronic Pressure Regulator is the DEPR. The DEPR is a "smart" actuator that is fed supply pressure through a DSR (Dual Stage Regulator). The DSR is fully mechanical. The DEPR receives fuel pressure commands from the ECM and quickly and precisely modulates fuel pressure to the gaseous fuel mixer. The DEPR allows for very fast and very accurate gaseous fuel control to provide a combustible mixture to the engine.</p> <p>The fourth generation of EControls' gaseous fuel control valve is the CFV. The CFV contains both a high-pressure Electronic Pressure Regulator and a precision Continuous Flow Valve. The inlet pressure to the CFV is typically 85 psig (586 kPa). The CFV receives mass flow commands from the ECM and quickly and precisely modulates both the fuel pressure and metering valve to achieve the desired mass flow. The CFV allows for very fast and very accurate gaseous fuel control to provide a combustible mixture to the engine.</p>
--------------------------------------	---

Possible Causes:	<p>This fault sets if the ECM loses CAN communication with the EPR/CFV. This fault indicates that the ECM is no longer receiving CAN packets from the EPR/CFV which also results in the EPR/CFV not receiving communication from the ECM. This is often a result of a power loss at the EPR/CFV or improper CAN termination or wiring. Adaptive fueling correction is disabled to avoid improper learning of the fuel correction table, closed-loop is disabled, and a Power Derate 1 condition is activated to reduce the possibility of engine damage. The MIL is illuminated for the duration of the key on cycle.</p>
-------------------------	---

Circuit Schematic:

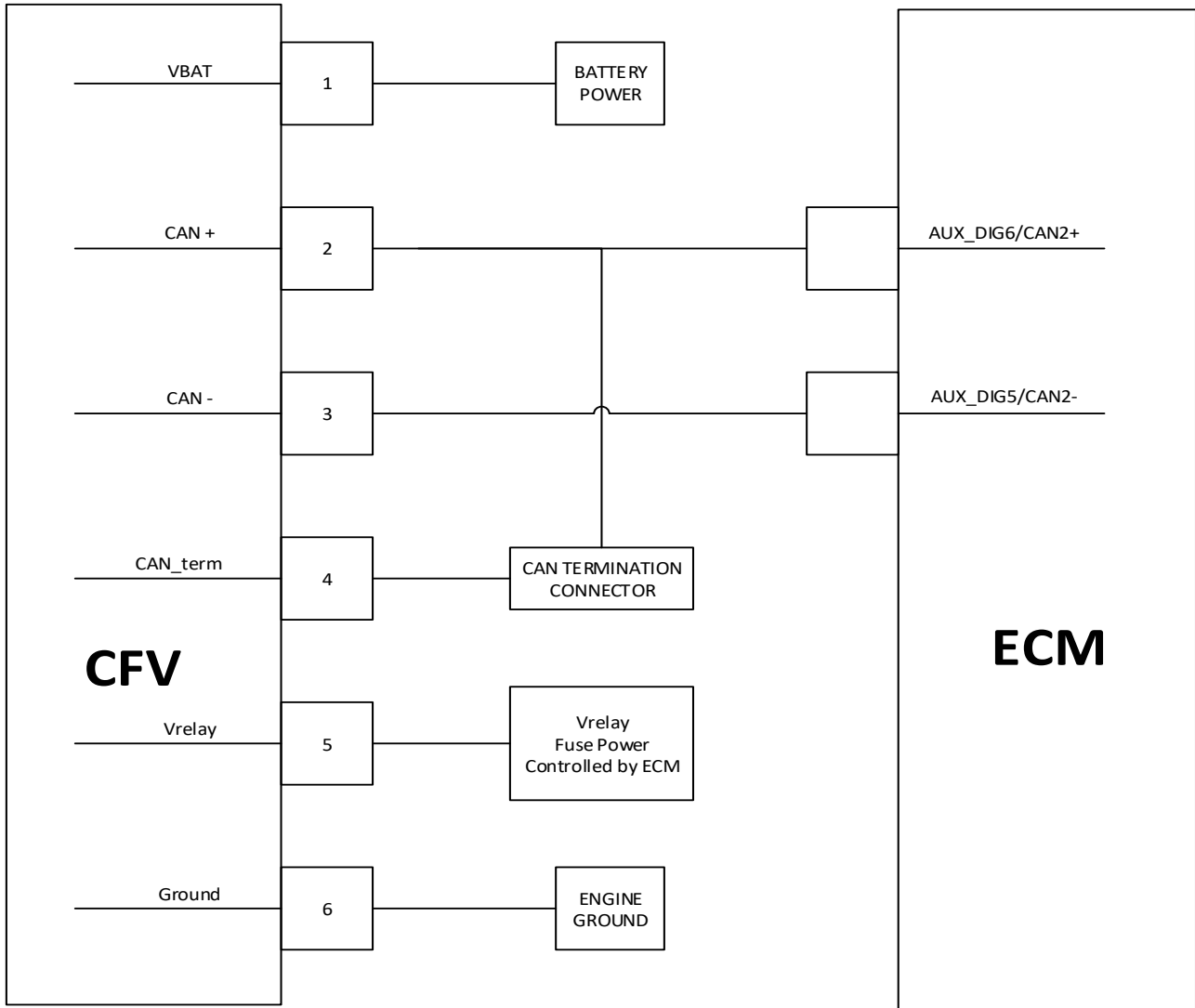

DTC 1173: Troubleshooting Tree

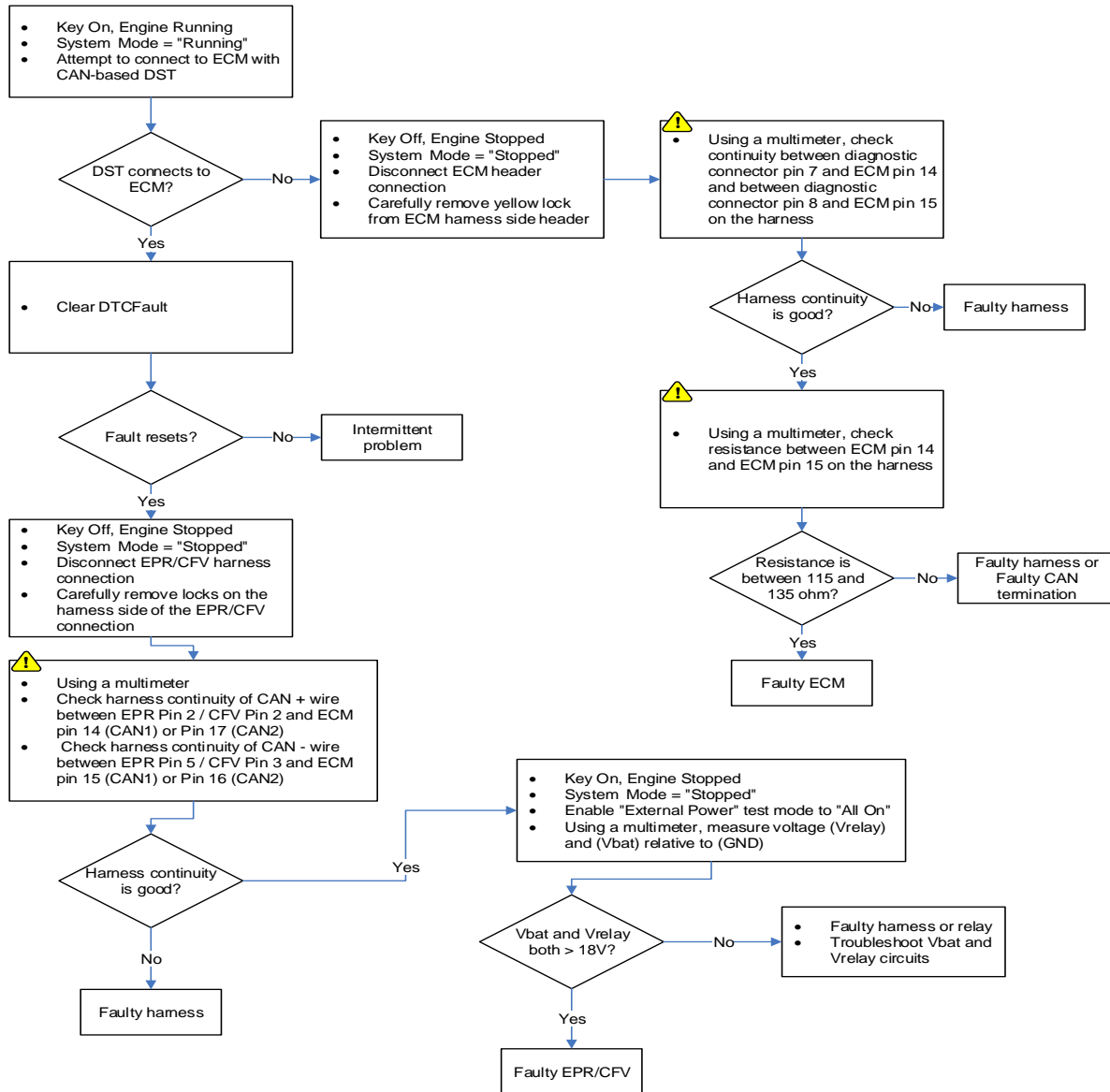

! NOTE: Do not insert probe or object into terminals as this will cause the terminal to spread and it may no longer make electrical contact with its mate. Spread pins will void warranty. Probe instead on side of terminal.

Code			Fault Description
DTC	SPN	FMI	
1174	520260	3	DEPR (MJ) Voltage Supply High

Hardware/Circuit Description:	<p>The EPR is the second generation of EControls' Electronic Pressure Regulator found in many industrial and heavy-duty applications. The 2nd generation EPR is a "smart" actuator integrated with the primary stage regulator designed to control gaseous fuel pressure in the secondary stage regulator. The EPR receives fuel pressure commands from the ECM and quickly and precisely modulates fuel pressure to the gaseous fuel mixer. The EPR allows for fast and accurate gaseous fuel control to provide a combustible mixture to the engine.</p> <p>The third generation of EControls' Electronic Pressure Regulator is the DEPR. The DEPR is a "smart" actuator that is fed supply pressure through a DSR (Dual Stage Regulator). The DSR is fully mechanical. The DEPR receives fuel pressure commands from the ECM and quickly and precisely modulates fuel pressure to the gaseous fuel mixer. The DEPR allows for very fast and very accurate gaseous fuel control to provide a combustible mixture to the engine.</p> <p>The fourth generation of EControls' gaseous fuel control valve is the CFV. The CFV contains both a high-pressure Electronic Pressure Regulator and a precision Continuous Flow Valve. The inlet pressure to the CFV is typically 85 psig (586 kPa). The CFV receives mass flow commands from the ECM and quickly and precisely modulates both the fuel pressure and metering valve to achieve the desired mass flow. The CFV allows for very fast and very accurate gaseous fuel control to provide a combustible mixture to the engine.</p>
--------------------------------------	---

Possible Causes:	<p>This fault sets if the supply voltage to the EPR/CFV exceeds 33.0 VDC for greater than 3 seconds. Adaptive fueling correction is disabled to avoid improper learning of the fuel correction table. The MIL will be illuminated for the duration of the key on cycle.</p>
-------------------------	---

Code			Fault Description
DTC	SPN	FMI	
1175	520260	4	DEPR (MJ) Voltage Supply Low

Hardware/Circuit Description:	<p>The EPR is the second generation of EControls' Electronic Pressure Regulator found in many industrial and heavy-duty applications. The 2nd generation EPR is a "smart" actuator integrated with the primary stage regulator designed to control gaseous fuel pressure in the secondary stage regulator. The EPR receives fuel pressure commands from the ECM and quickly and precisely modulates fuel pressure to the gaseous fuel mixer. The EPR allows for fast and accurate gaseous fuel control to provide a combustible mixture to the engine.</p> <p>The third generation of EControls' Electronic Pressure Regulator is the DEPR. The DEPR is a "smart" actuator that is fed supply pressure through a DSR (Dual Stage Regulator). The DSR is fully mechanical. The DEPR receives fuel pressure commands from the ECM and quickly and precisely modulates fuel pressure to the gaseous fuel mixer. The DEPR allows for very fast and very accurate gaseous fuel control to provide a combustible mixture to the engine</p> <p>The fourth generation of EControls' gaseous fuel control valve is the CFV. The CFV contains both a high-pressure Electronic Pressure Regulator and a precision Continuous Flow Valve. The inlet pressure to the CFV is typically 85 psig (586 kPa). The CFV receives mass flow commands from the ECM and quickly and precisely modulates both the fuel pressure and metering valve to achieve the desired mass flow. The CFV allows for very fast and very accurate gaseous fuel control to provide a combustible mixture to the engine.</p>
--------------------------------------	--

Possible Causes:	<p>This fault sets if the supply voltage to the EPR/CFV is below 18.0 VDC for > 5 seconds while engine RPM > 1000. Adaptive fueling correction is disabled to avoid improper learning of the fuel correction table. The MIL will be illuminated for the duration of the key on cycle.</p>
-------------------------	---

Code			Fault Description
DTC	SPN	FMI	
1176	520260	12	DEPR (MJ) Internal Actuator Fault

Hardware/Circuit Description:	<p>The EPR is the second generation of EControls' Electronic Pressure Regulator found in many industrial and heavy-duty applications. The 2nd generation EPR is a "smart" actuator integrated with the primary stage regulator designed to control gaseous fuel pressure in the secondary stage regulator. The EPR receives fuel pressure commands from the ECM and quickly and precisely modulates fuel pressure to the gaseous fuel mixer. The EPR allows for fast and accurate gaseous fuel control to provide a combustible mixture to the engine.</p> <p>The third generation of EControls' Electronic Pressure Regulator is the DEPR. The DEPR is a "smart" actuator that is fed supply pressure through a DSR (Dual Stage Regulator). The DSR is fully mechanical. The DEPR receives fuel pressure commands from the ECM and quickly and precisely modulates fuel pressure to the gaseous fuel mixer. The DEPR allows for very fast and very accurate gaseous fuel control to provide a combustible mixture to the engine.</p> <p>The fourth generation of EControls' gaseous fuel control valve is the CFV. The CFV contains both a high-pressure Electronic Pressure Regulator and a precision Continuous Flow Valve. The inlet pressure to the CFV is typically 85 psig (586 kPa). The CFV receives mass flow commands from the ECM and quickly and precisely modulates both the fuel pressure and metering valve to achieve the desired mass flow. The CFV allows for very fast and very accurate gaseous fuel control to provide a combustible mixture to the engine.</p>
--------------------------------------	---

Possible Causes:	<p>This fault sets if the EPR/CFV detects an internal actuator fault. The fault is transmitted from the EPR/CFV to the ECM via CAN. If the fault is active, Adaptive Learn is disabled to prevent improper learning and updating of the table. The MIL is illuminated for the duration of the key on cycle.</p> <p>If the EPR/CFV does not trigger either 1171, 1172, or either of the CFV Flow fault code(s), there is no issue with the EPR/CFV. If one or more of these faults are triggered, refer to the appropriate section for diagnostic information.</p>
-------------------------	---

Code			Fault Description
DTC	SPN	FMI	
1177	520260	12	DEPR (MJ) Internal Circuitry Fault Detection

Hardware/Circuit Description:	<p>The EPR is the second generation of EControls' Electronic Pressure Regulator found in many industrial and heavy-duty applications. The 2nd generation EPR is a "smart" actuator integrated with the primary stage regulator designed to control gaseous fuel pressure in the secondary stage regulator. The EPR receives fuel pressure commands from the ECM and quickly and precisely modulates fuel pressure to the gaseous fuel mixer. The EPR allows for fast and accurate gaseous fuel control to provide a combustible mixture to the engine.</p> <p>The third generation of EControls' Electronic Pressure Regulator is the DEPR. The DEPR is a "smart" actuator that is fed supply pressure through a DSR (Dual Stage Regulator). The DSR is fully mechanical. The DEPR receives fuel pressure commands from the ECM and quickly and precisely modulates fuel pressure to the gaseous fuel mixer. The DEPR allows for very fast and very accurate gaseous fuel control to provide a combustible mixture to the engine</p> <p>The fourth generation of EControls' gaseous fuel control valve is the CFV. The CFV contains both a high-pressure Electronic Pressure Regulator and a precision Continuous Flow Valve. The inlet pressure to the CFV is typically 85 psig (586 kPa). The CFV receives mass flow commands from the ECM and quickly and precisely modulates both the fuel pressure and metering valve to achieve the desired mass flow. The CFV allows for very fast and very accurate gaseous fuel control to provide a combustible mixture to the engine.</p>
--------------------------------------	--

Possible Causes:	<p>This fault sets if the EPR/CFV detects an internal circuitry fault. The fault is transmitted from the EPR/CFV to the ECM via CAN. If the fault is active, Adaptive Learn is disabled to prevent improper learning and updating of the table. The MIL is illuminated for the duration of the key on cycle.</p> <p>If the EPR/CFV does not trigger either 1171, 1172, or either of the CFV Flow fault code(s), there is no issue with the EPR/CFV. If one or more of these faults are triggered, refer to the appropriate section for diagnostic information.</p>
-------------------------	--

Code			Fault Description
DTC	SPN	FMI	
1178	520260	12	DEPR (MJ) Internal Comm Fault Detection

Hardware/Circuit Description:	<p>The EPR is the second generation of EControls' Electronic Pressure Regulator found in many industrial and heavy-duty applications. The 2nd generation EPR is a "smart" actuator integrated with the primary stage regulator designed to control gaseous fuel pressure in the secondary stage regulator. The EPR receives fuel pressure commands from the ECM and quickly and precisely modulates fuel pressure to the gaseous fuel mixer. The EPR allows for fast and accurate gaseous fuel control to provide a combustible mixture to the engine.</p> <p>The third generation of EControls' Electronic Pressure Regulator is the DEPR. The DEPR is a "smart" actuator that is fed supply pressure through a DSR (Dual Stage Regulator). The DSR is fully mechanical. The DEPR receives fuel pressure commands from the ECM and quickly and precisely modulates fuel pressure to the gaseous fuel mixer. The DEPR allows for very fast and very accurate gaseous fuel control to provide a combustible mixture to the engine</p> <p>The fourth generation of EControls' gaseous fuel control valve is the CFV. The CFV contains both a high-pressure Electronic Pressure Regulator and a precision Continuous Flow Valve. The inlet pressure to the CFV is typically 85 psig (586 kPa). The CFV receives mass flow commands from the ECM and quickly and precisely modulates both the fuel pressure and metering valve to achieve the desired mass flow. The CFV allows for very fast and very accurate gaseous fuel control to provide a combustible mixture to the engine.</p>
--------------------------------------	--

Possible Causes:	<p>This fault sets if the EPR/CFV detects an internal circuitry fault. The fault is transmitted from the EPR/CFV to the ECM via CAN. If the fault is active, Adaptive Learn is disabled to prevent improper learning and updating of the table. The MIL is illuminated for the duration of the key on cycle.</p> <p>If the EPR/CFV does not trigger either 1171, 1172, or either of the CFV Flow fault code(s), there is no issue with the EPR/CFV. If one or more of these faults are triggered, refer to the appropriate section for diagnostic information.</p>
-------------------------	--

Code			Fault Description
DTC	SPN	FMI	
1325	731	15	Knock Retard at Limit

Description:	<p>Knock Retard (hereafter referred to as KR) is the response from the ECM to cylinder detonation. KR is the measure of the number of degrees of overall ignition timing advance that must be removed from the engine to prevent detonation from continuing, protecting the engine from damage. Occurs with the below conditions</p> <table border="1" style="margin-left: auto; margin-right: auto;"> <tr> <td style="text-align: right;">RPM ></td> <td>1500 rpm</td> <td>20.000</td> </tr> <tr> <td style="text-align: right;">and MAP ></td> <td>8.00 psia</td> <td></td> </tr> <tr> <td style="text-align: right;">and knock spark retard at percent of maximum</td> <td>100 %</td> <td></td> </tr> </table>	RPM >	1500 rpm	20.000	and MAP >	8.00 psia		and knock spark retard at percent of maximum	100 %	
RPM >	1500 rpm	20.000								
and MAP >	8.00 psia									
and knock spark retard at percent of maximum	100 %									

Possible Causes:	Fuel is too low of an octane rating.
	Incorrect Spark Plugs
	Anything loose in the engine or outside the engine may cause noises that drift through the frequency range that the PCM detects as KR
	Loose knock sensors, or knock sensors that are too tight. Double check that your knock sensors are torqued to their specifications (14 lb-ft).

Code			Fault Description
DTC	SPN	FMI	
1351	1268	11	Spark Plug or Coil Failure Cylinder 1
1352	1269	11	Spark Plug or Coil Failure Cylinder 2
1353	1270	11	Spark Plug or Coil Failure Cylinder 3
1354	1271	11	Spark Plug or Coil Failure Cylinder 4
1355	1272	11	Spark Plug or Coil Failure Cylinder 5
1356	1273	11	Spark Plug or Coil Failure Cylinder 6
1357	1274	11	Spark Plug or Coil Failure Cylinder 7
1358	1275	11	Spark Plug or Coil Failure Cylinder 8
1359	1276	11	Spark Plug or Coil Failure Cylinder 9
1360	1277	11	Spark Plug or Coil Failure Cylinder 10

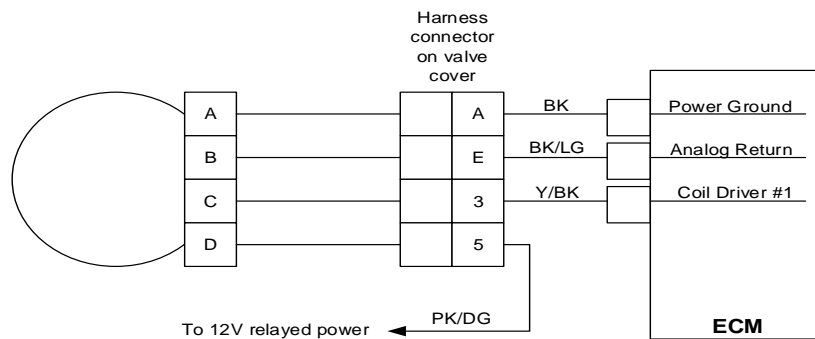

Hardware/Circuit:	Ignition/Spark Coil, cylinders 1-10 (Dumb-coil ONLY)
--------------------------	--

Hardware/Circuit Description:	Coil driver #1 fires either the 1st cylinder in the firing order or the 1st cylinder in the block order depending on the configuration of the 'Injector/Spark Diagnostic Numbering' scheme as set in calibration. Drivers 2-10 follow in-kind.
--------------------------------------	--

<p>Possible Causes:</p>	<p>This fault will set if the ECM detects that the spark/ignition drive circuitry within the ECM is over-heating. Once over-heating is detected and this fault is active, the ECM will kill spark on the affected channel until x seconds after the drive circuit cools or until the key switch is cycled depending upon the selection made in the diagnostic calibration.</p> <p>Typical causes of this fault include:</p> <ul style="list-style-type: none"> • Shorted coil • Poor quality coil • Coil loose from spark plug • Plug gap too large (all inductive energy goes back on driver) • Dwell time is set too long in the diagnostic calibration • Ambient temp too high
--------------------------------	---

<p>Diagnostic Aids</p> <ul style="list-style-type: none"> <input type="checkbox"/> Check plug gap on the cylinder associated with the fault. <input type="checkbox"/> Check for loose connections at the coil and spark plugs. Look for evidence of charring or arcing around spark plugs. <input type="checkbox"/> Check coil resistance and verify that it is within specifications. Look for a short internal to the coil. <input type="checkbox"/> Ensure the use of high quality coils without a history of internal arcing or other failures. <input type="checkbox"/> Verify that ambient conditions are not exceeding 85C on a continuous basis or 125C for short intervals. If so, verify that this fault stops occurring when ambient temperatures lower. <input type="checkbox"/> Verify the dwell time set in the diagnostic calibration is not set too long and that adaptive dwell is enabled.

Code			Fault Description
DTC	SPN	FMI	
1512	701	4	AUX Analog PU1 Low Voltage

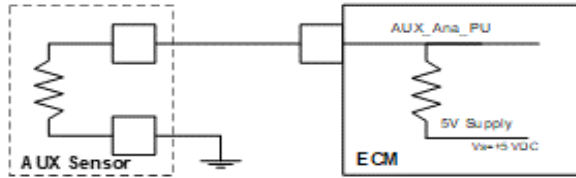

Hardware/Circuit:	Auxiliary Sensor (proportional voltage type). Fuel Block
--------------------------	--

Hardware/Circuit Description:	<p>The auxiliary analog input circuit is customer specific and can be used to perform an action based on a sensor that switches to ground or a sensor that outputs a proportional voltage. Typical uses of the auxiliary circuit include switches that activate particular software strategies, switches that act as vehicle safeties to trigger derate or shutdown conditions, or auxiliary senders used to drive gauges.</p> <p>The circuit internal to the ECM is connected in parallel with the regulated 5 VDC power supply so that when no load is connected to the circuit the feedback voltage is equal to 5 VDC.</p>
--------------------------------------	---

Possible Causes:	<p>This fault is active when the voltage feedback from the sensor is BELOW the limit defined in calibration.</p> <p>This circuit is the sensor signal from the fuel block temperature probe in the fuel block. This fault can only occur on gasoline. This fault indicates that the pressure has dropped below 0.200 volts and is configuration #1 listed above.</p> <p>Pin 38 of the GCP, light green/white wire.</p>
-------------------------	--

DTC 1512: Troubleshooting Tree

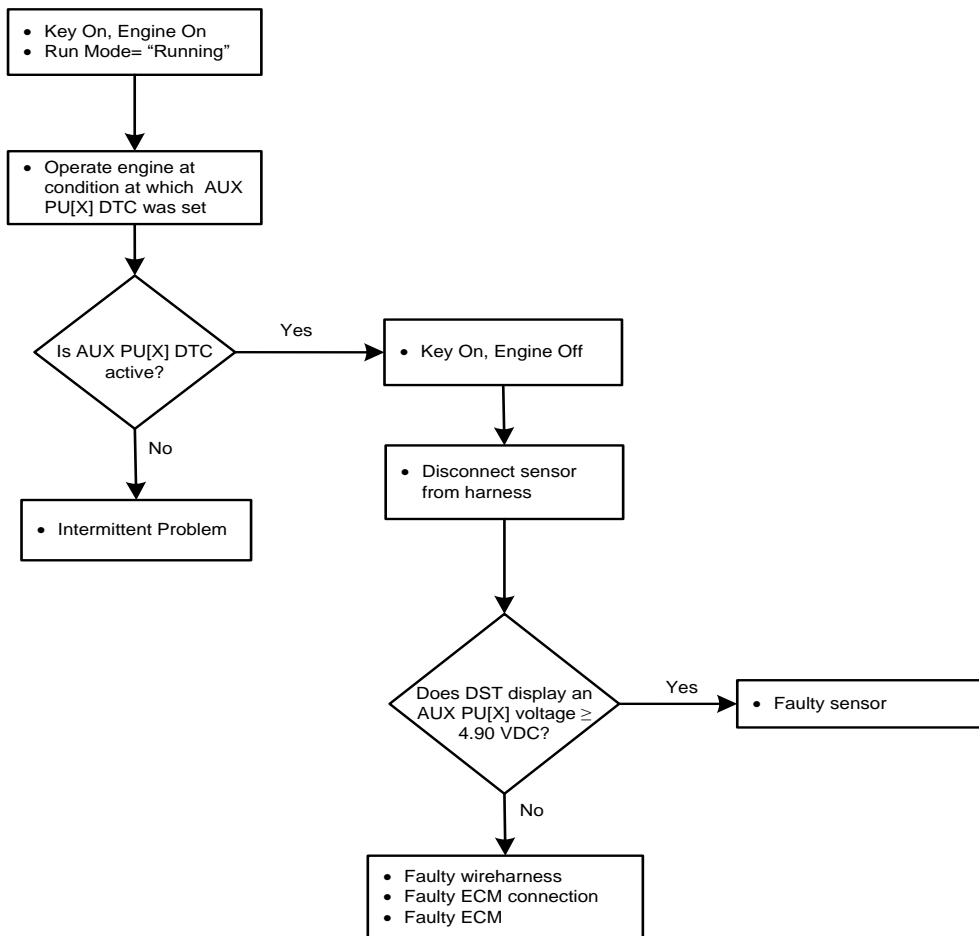

Code			Fault Description
DTC	SPN	FMI	
1521	110	16	CHT Higher Than Expected Stage 1

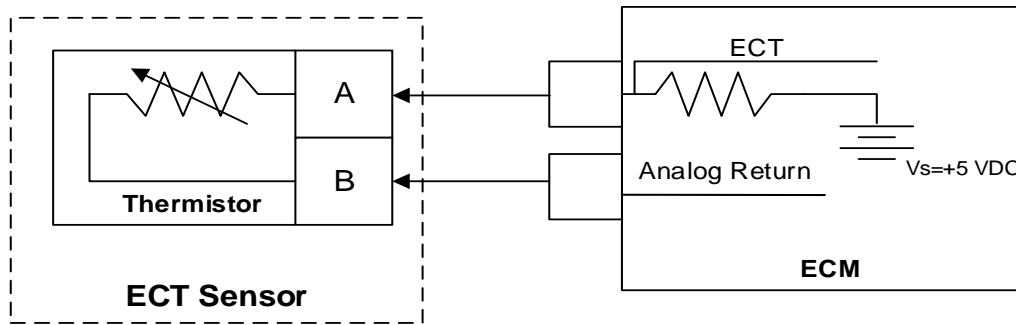

Hardware/Circuit:	Cylinder Head Temperature Sensor
--------------------------	----------------------------------

Hardware/Circuit Description:	<p>The Engine Coolant Temperature sensor is a thermistor (temperature sensitive resistor) located in the engine coolant. Some engines use a CHT sensor that is located in the coolant in the cylinder head. Some engines use an ECT (Engine Coolant Temperature) sensor that is located in the coolant near the thermostat. If the engine is equipped with a CHT sensor then the ECT value is estimated. If equipped with an ECT sensor then the CHT value is estimated. They are used for engine airflow calculation, ignition timing control, to enable certain features, and for engine protection. The ECM provides a voltage divider circuit so when the sensor reading is cool the sensor reads higher voltage, and lower when warm.</p>
--------------------------------------	--

Possible Causes:	<p>This fault will help protect the engine in the event of over temperature. When the coolant exceeds x deg. F and engine RPM exceeds y RPM for the latch time this fault will set.</p>
-------------------------	---

DTC 1521- CHT Higher Than Expected Stage 1 (Diagnostic Aids)

- If the “ECT High Voltage” fault is also present, follow the troubleshooting procedures for that fault as it may have caused “ECT Higher Than Expected 1.”
- If the cooling system utilizes an air-to-water heat exchanger (radiator) and fan:
 - Check that the radiator has a proper amount of ethylene glycol/water and that the radiator is not leaking
 - Ensure that there is no trapped air in the cooling path
 - Inspect the cooling system (radiator and hoses) for cracks and ensure connections are leak free
 - Check that the fan is operating properly
 - Check that the thermostat is not stuck closed
- If the cooling system utilizes a water-to-water heat exchanger:
 - Check that the heat exchanger has a proper amount of ethylene glycol/water and that the heat exchanger is not leaking
 - Ensure that there is no trapped air in the cooling path
 - Inspect the cooling system (radiator and hoses) for cracks and ensure connections are leak free
 - Check that the raw water pickup is not blocked/restricted by debris and that the hose is tightly connected
 - Check that the thermostat is not stuck closed

Check that the raw water pump/impeller is tact and that it is not restricted

Code			Fault Description
DTC	SPN	FMI	
1522	110	0	CHT Higher Than Expected Stage 2

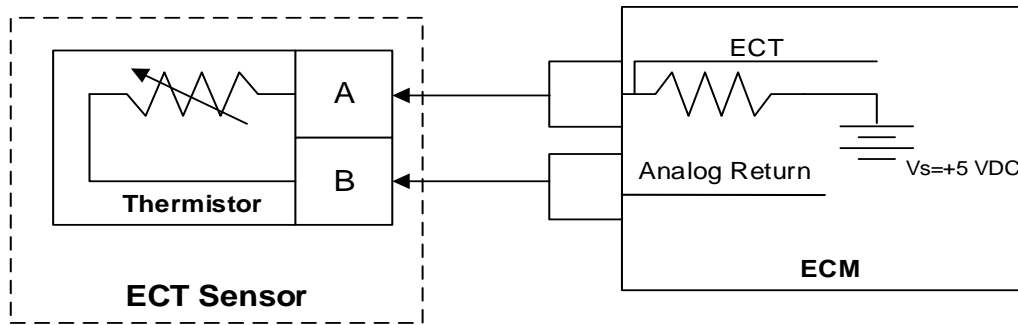

Hardware/Circuit:	Cylinder Head Temperature Sensor
--------------------------	----------------------------------

Hardware/Circuit Description:	<p>The Engine Coolant Temperature sensor is a thermistor (temperature sensitive resistor) located in the engine coolant. Some engines use a CHT sensor that is located in the coolant in the cylinder head. Some engines use an ECT (Engine Coolant Temperature) sensor that is located in the coolant near the thermostat. If the engine is equipped with a CHT sensor then the ECT value is estimated. If equipped with an ECT sensor then the CHT value is estimated. They are used for engine airflow calculation, ignition timing control, to enable certain features, and for engine protection. The ECM provides a voltage divider circuit so when the sensor reading is cool the sensor reads higher voltage, and lower when warm.</p>
--------------------------------------	--

Possible Causes:	<p>This fault will help protect the engine in the event of over temperature. When the coolant exceeds x deg. F and engine RPM exceeds y RPM for the latch time this fault will set.</p>
-------------------------	---

DTC 1522- CHT Higher Than Expected Stage 2 (Diagnostic Aids)

- If the “ECT High Voltage” fault is also present, follow the troubleshooting procedures for that fault as it may have caused “ECT Higher Than Expected 2.”
- If the cooling system utilizes an air-to-water heat exchanger (radiator) and fan:
 - Check that the radiator has a proper amount of ethylene glycol/water and that the radiator is not leaking
 - Ensure that there is no trapped air in the cooling path
 - Inspect the cooling system (radiator and hoses) for cracks and ensure connections are leak free
 - Check that the fan is operating properly
 - Check that the thermostat is not stuck closed
- If the cooling system utilizes a water-to-water heat exchanger:
 - Check that the heat exchanger has a proper amount of ethylene glycol/water and that the heat exchanger is not leaking
 - Ensure that there is no trapped air in the cooling path
 - Inspect the cooling system (radiator and hoses) for cracks and ensure connections are leak free
 - Check that the raw water pickup is not blocked/restricted by debris and that the hose is tightly connected
 - Check that the thermostat is not stuck closed

Check that the raw water pump/impeller is tact and that it is not restricted

Code			Fault Description
DTC	SPN	FMI	
1561	711	3	AUX Analog Pull-Down High Voltage Fault

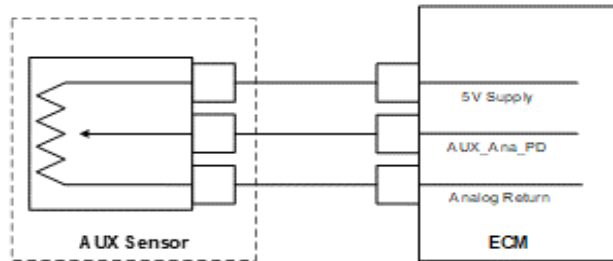

Hardware/Circuit:	Auxiliary Sensor (proportional voltage type); Fuel Block
--------------------------	--

Hardware/Circuit Description:	<p>The auxiliary analog input circuit is customer specific and can be used to perform an action based on a sensor that switches to ground or a sensor that outputs a proportional voltage. Typical uses of the auxiliary circuit include switches that activate particular software strategies, switches that act as vehicle safeties to trigger derate or shutdown conditions, or auxiliary senders used to drive gauges.</p> <p>The circuit internal to the ECM is connected in parallel ground so that when no load is connected to the circuit the feedback voltage is equal to 0 VDC.</p>
--------------------------------------	--

Possible Causes:	<p>This fault is active when the voltage feedback from the sensor is ABOVE the limit defined in calibration.</p> <p>This is the fuel rail pressure signal fault. If the signal voltage is high the fuel block is either faulty or a short is in the wire. White/lt green wire of gasoline sensor block to Pin 13 of the GCP Connector. If this is above 2.8 volts the fault will set.</p> <p>The fuel pump is grounded via a PWM control to achieve the correct pressure. Verify it is grounded via the ECU PWM control as directly grounding the fuel pump will cause this fault code.</p> <p>If the wiring and fuel block are ok, replace the ECU with a known working one.</p>
-------------------------	---

DTC 1561: Troubleshooting Tree

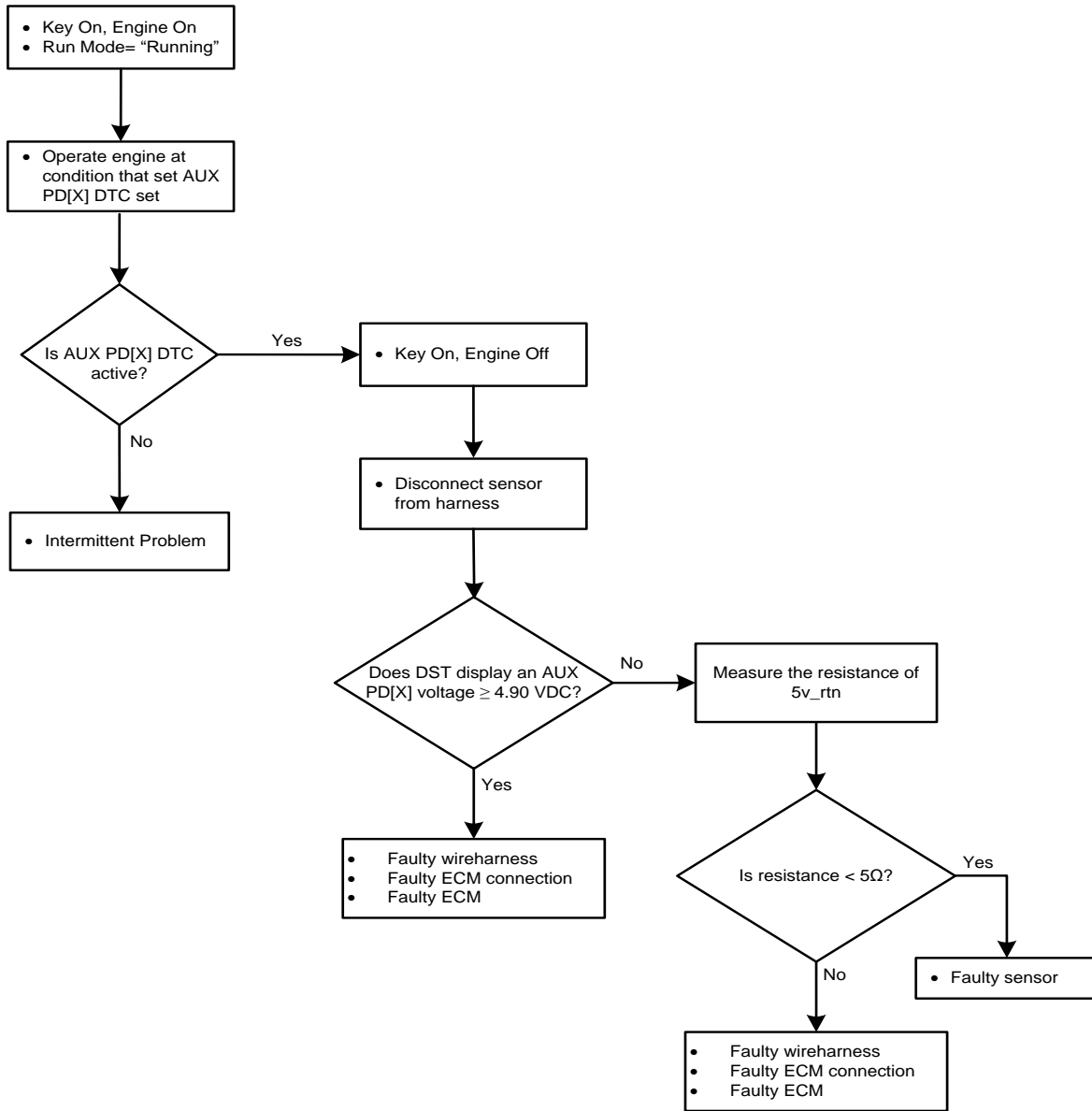

Code			Fault Description
DTC	SPN	FMI	
1612	629	31	RTI 1 Loss
1613	629	31	RTI 2 Loss
1614	629	31	RTI 3 Loss

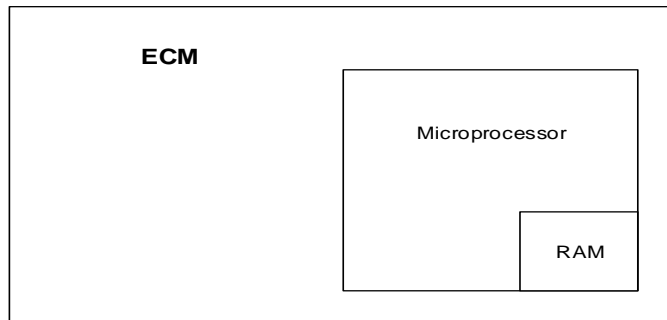

Hardware/Circuit:	Engine Control Module
--------------------------	-----------------------

Hardware/Circuit Description:	The ECM will reset itself in the event this fault is set, and the MIL will be on until the code is cleared. This fault should be erased after diagnosis. It will not self-erase.
--------------------------------------	--

Possible Causes:	The ECM microprocessor verifies the real-time contexts are being processed in a timely manner. If one or more of the real-time contexts does not complete within the allotted timeframe, the fault will set, and the ECM will reset.
-------------------------	--

DTC 1612-1613-1614: Troubleshooting Tree

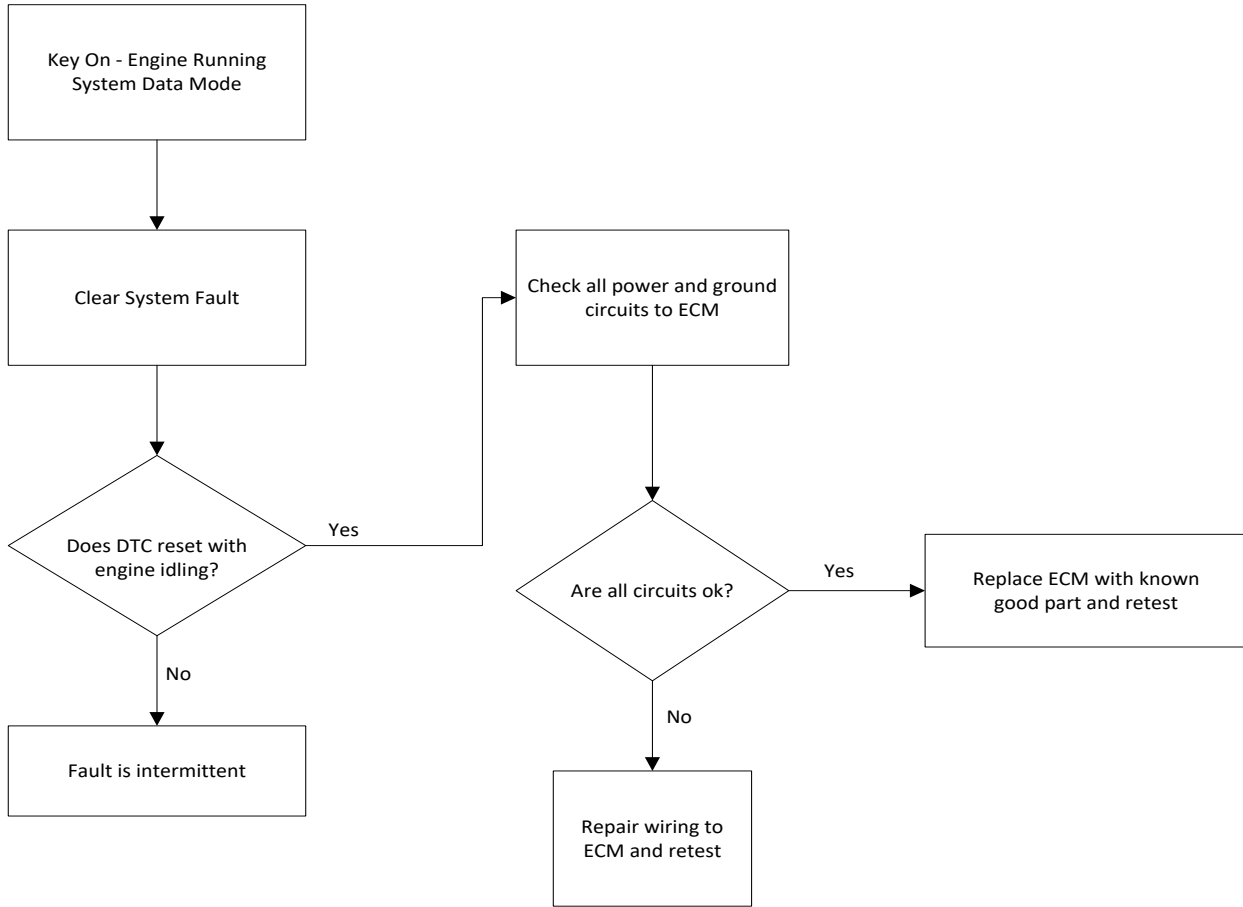

Code			Fault Description
DTC	SPN	FMI	
1615	629	31	Microprocessor Failure - A/D Loss

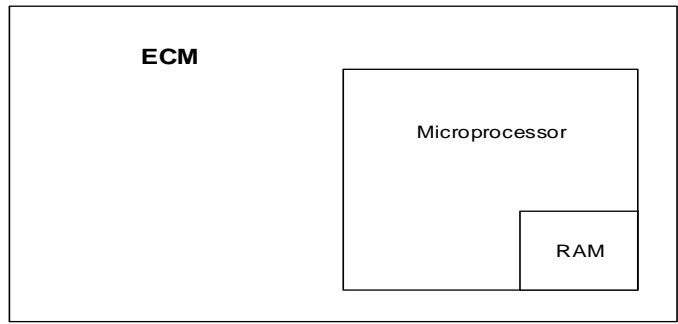

Hardware/Circuit:	Engine Control Module
--------------------------	-----------------------

Hardware/Circuit Description:	The ECM will reset itself in the event this fault is set, and the MIL will be on until the code is cleared.
--------------------------------------	---

NOTE: This fault is not implemented in the 4G System.

Code			Fault Description
DTC	SPN	FMI	
1616	629	31	Microprocessor Failure - Interrupt

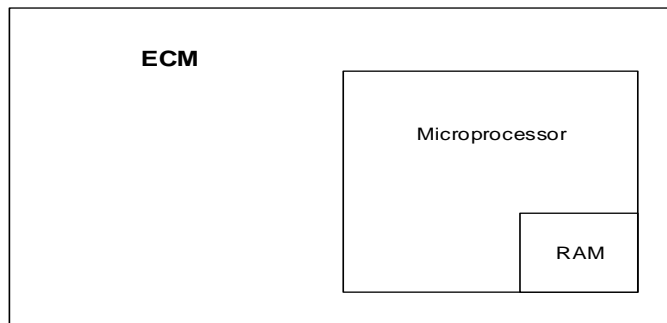

Hardware/Circuit:	Engine Control Module
--------------------------	-----------------------

Hardware/Circuit Description:	<p>The ECM will reset itself in the event this fault is set, and the MIL will be on until the code is cleared. This fault should be erased after diagnosis by removing battery power. It will not self-erase.</p> <p>During this active fault, Power Derate (level 2) will be enforced. When this is enforced, maximum throttle position will be 20%. This is enforced until the fault is manually cleared.</p>
--------------------------------------	---

Possible Causes:	The ECM has checks for unhandled/unexpected interrupts. Several different things can happen within the microprocessor that will cause this fault.
-------------------------	---

DTC 1616: Troubleshooting Tree

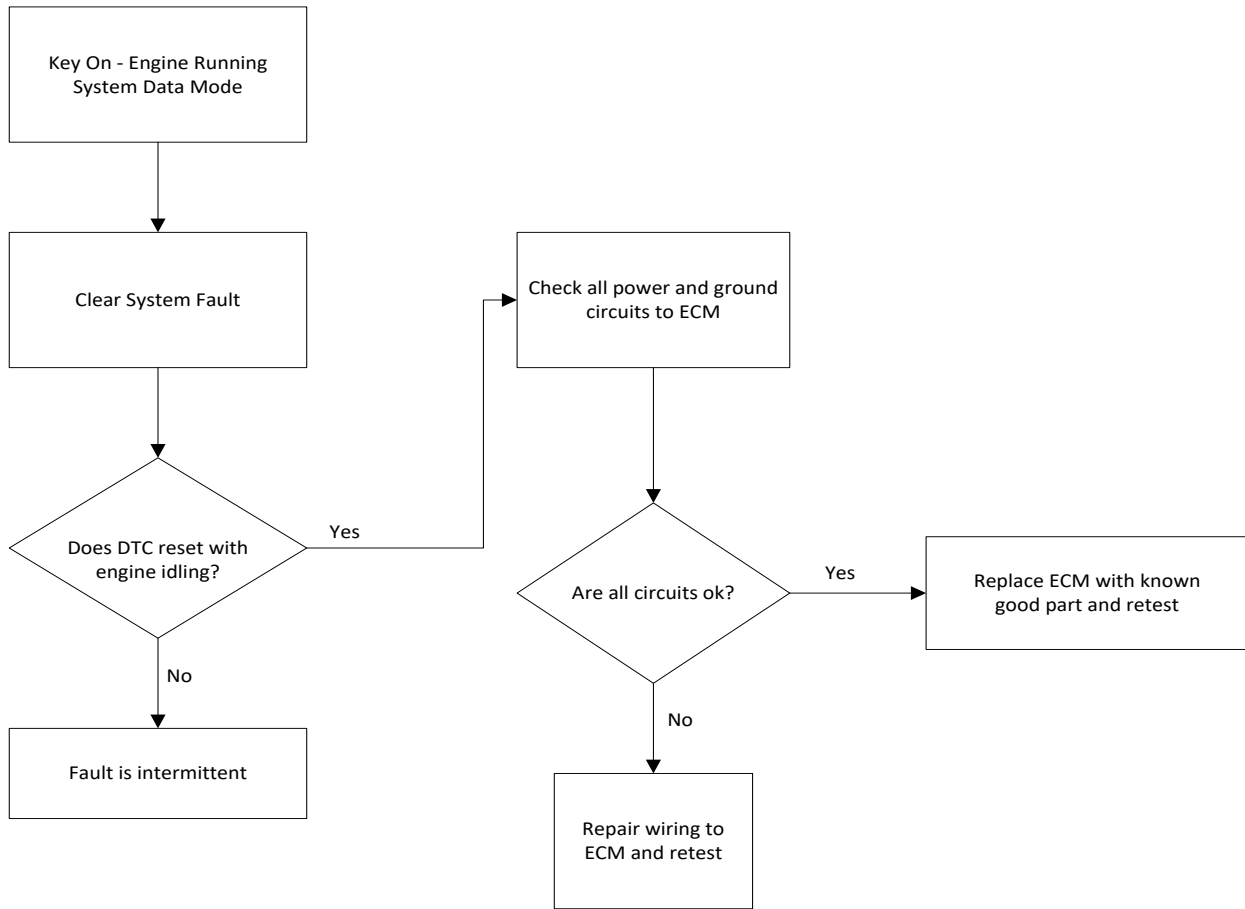

Code			Fault Description
DTC	SPN	FMI	
1625	1110	31	J1939 Shutdown Request

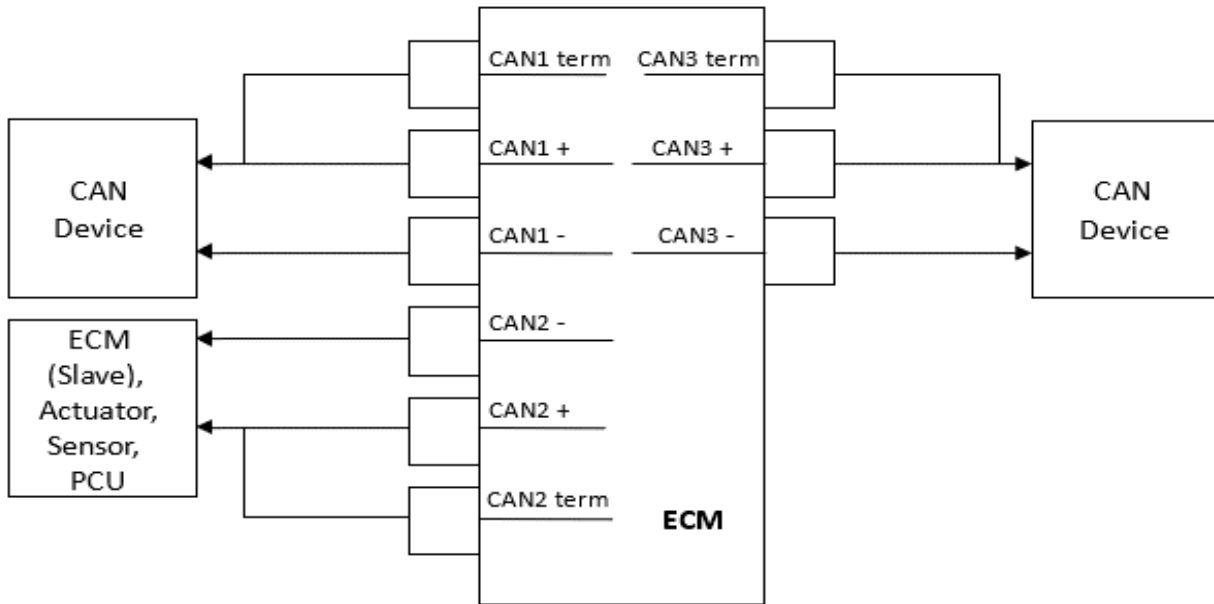

Hardware/Circuit:	CAN Device(s)
Hardware/Circuit Description:	CAN Bus system
Possible Causes:	This fault indicates that the OEM controller sent a CAN Shutdown request to the ECU.

Code			Fault Description
DTC	SPN	FMI	
1628	639	13	CAN Address Conflict Failure

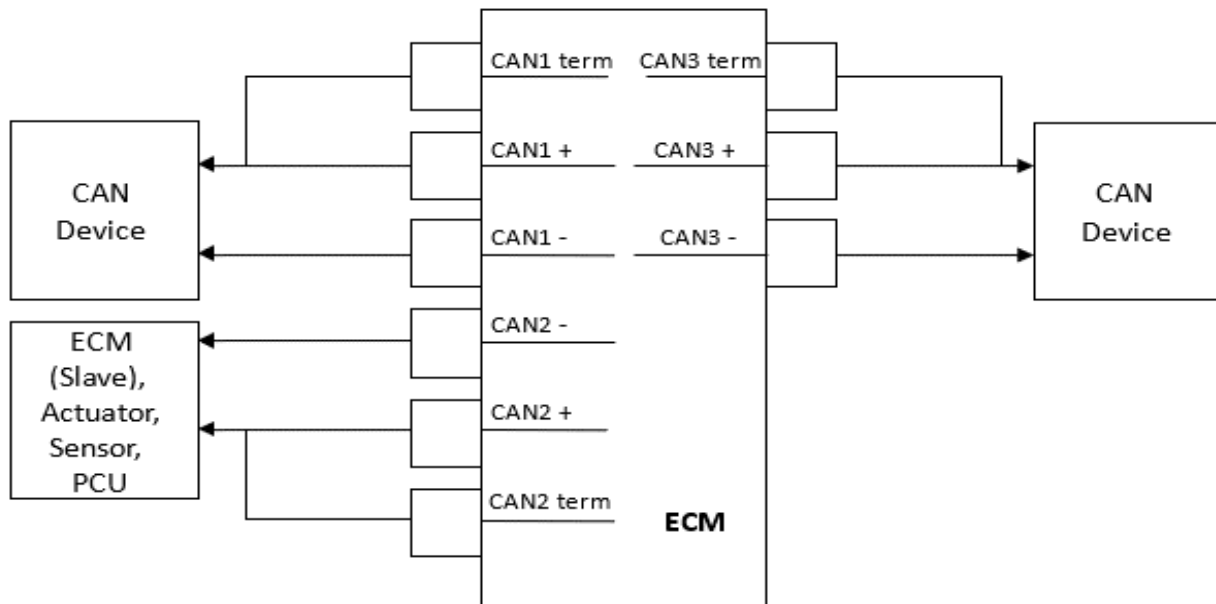

Hardware/Circuit:	CAN Device(s)
--------------------------	---------------

Hardware/Circuit Description:	<p>The controller area network serves as a communication portal between intelligent devices. These devices may be but are not limited to other engine ECMs (slave), diagnostic tools, “smart” gauges, “smart” sensors, powertrain control units, vehicle controllers, actuators, etc. The network permits several devices to communicate with each other receiving and broadcasting commands as programmed. This type of network allows devices to be added to an entire system through only two conductors and permits all other devices to broadcast and receive commands to and from the device when properly commanded.</p> <ul style="list-style-type: none"> •CAN1 is used for general network communication including gauge display, scan tool communication, and other general 3rd party traffic. •CAN2 is reserved solely for engine control (engine synchronization, throttle control, vehicle controller commands, etc.) and is limited to EControls Inc. approved devices only. •CAN3 is used for communication with CAN-based UEGO sensors in some Stoichiometric/EGR applications. NOTE: Most 4G ECMs do not utilize CAN3 at this point.
--------------------------------------	---

Possible Causes:	This fault indicates that there are two (2) or more devices on the network that use the same source address.
-------------------------	--

DTC 1628: Troubleshooting Tree

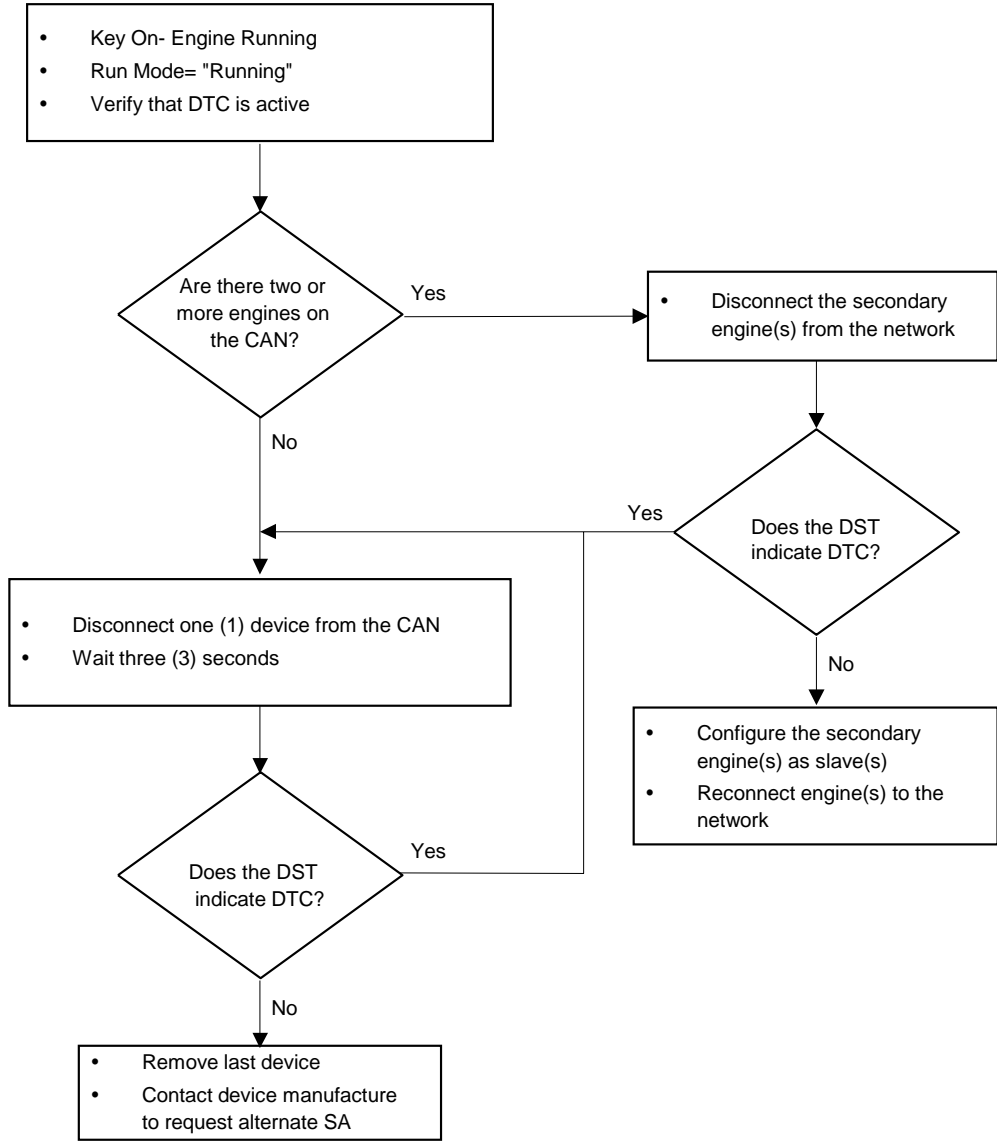

Code			Fault Description
DTC	SPN	FMI	
1629	695	9	J1939 TSC1 Message Receipt Loss

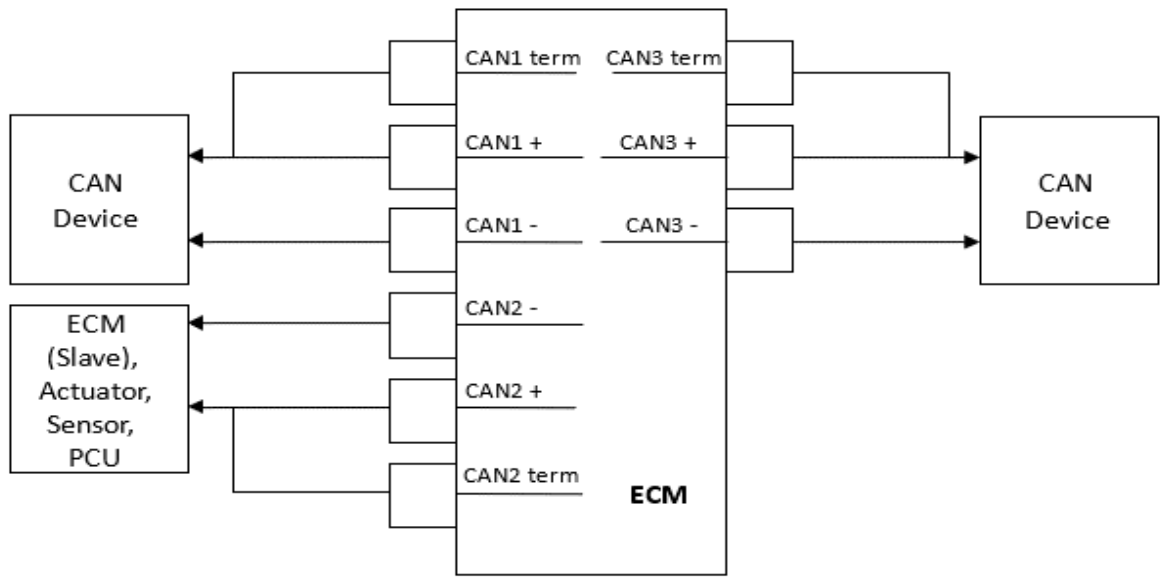

Hardware/Circuit:	CAN Device(s)
--------------------------	---------------

Hardware/Circuit Description:	<p>The controller area network serves as a communication portal between intelligent devices. These devices may be but are not limited to other engine ECMs (slave), diagnostic tools, “smart” gauges, “smart” sensors, powertrain control units, vehicle controllers, actuators, etc. The network permits several devices to communicate with each other receiving and broadcasting commands as programmed. This type of network allows devices to be added to an entire system through only two conductors and permits all other devices to broadcast and receive commands to and from the device when properly commanded.</p> <ul style="list-style-type: none"> •CAN1 is used for general network communication including gauge display, scan tool communication, and other general 3rd party traffic. •CAN2 is reserved solely for engine control (engine synchronization, throttle control, vehicle controller commands, etc.) and is limited to EControls Inc. approved devices only. •CAN3 is used for communication with CAN-based UEGO sensors in some Stoichiometric/EGR applications. NOTE: Most 4G ECMs do not utilize CAN3 at this point.
--------------------------------------	---

Possible Causes:	<p>This fault is enabled if the application is using a J1939 TSC1 controller to control the engine speed. This indicates that it has lost communication with the controller and is not receiving the engine speed data anymore.</p> <p>This could be a result of damaged wiring from the controller to the GCP (CAN+ and CAN-) or a fault in the applications controller. It could also be the result of the source address of the controller not matching what the ECU is expecting</p>
-------------------------	--

Code			Fault Description
DTC	SPN	FMI	
1631	697	5	PWM1-Gauge1 open / ground short
1633	698	5	PWM1-Gauge2 open / ground short
1635	699	5	PWM1-Gauge3 open / ground short

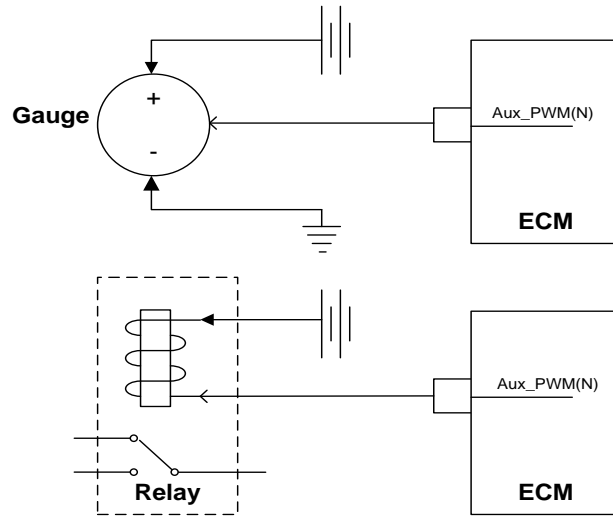

Hardware/Circuit:	Analog gauge, proportional actuator, on-off device (see examples above)
--------------------------	---

Hardware/Circuit Description:	<p>AUX_PWM(1-3) is an output that, depending on the ECM HW configuration, may be used to:</p> <ul style="list-style-type: none"> • Simulate the resistance of a sender to drive an analog gauge (Gauge driver config) • PWM an analog gauge (PWM config) • PWM the low-side of an on-off device (PWM config) • PWM a proportional actuator (PWM config)
--------------------------------------	---

Possible Causes:	AUX PWM output open circuit or shorted to ground
-------------------------	--

DTC 1631-1633-1635: Troubleshooting Tree

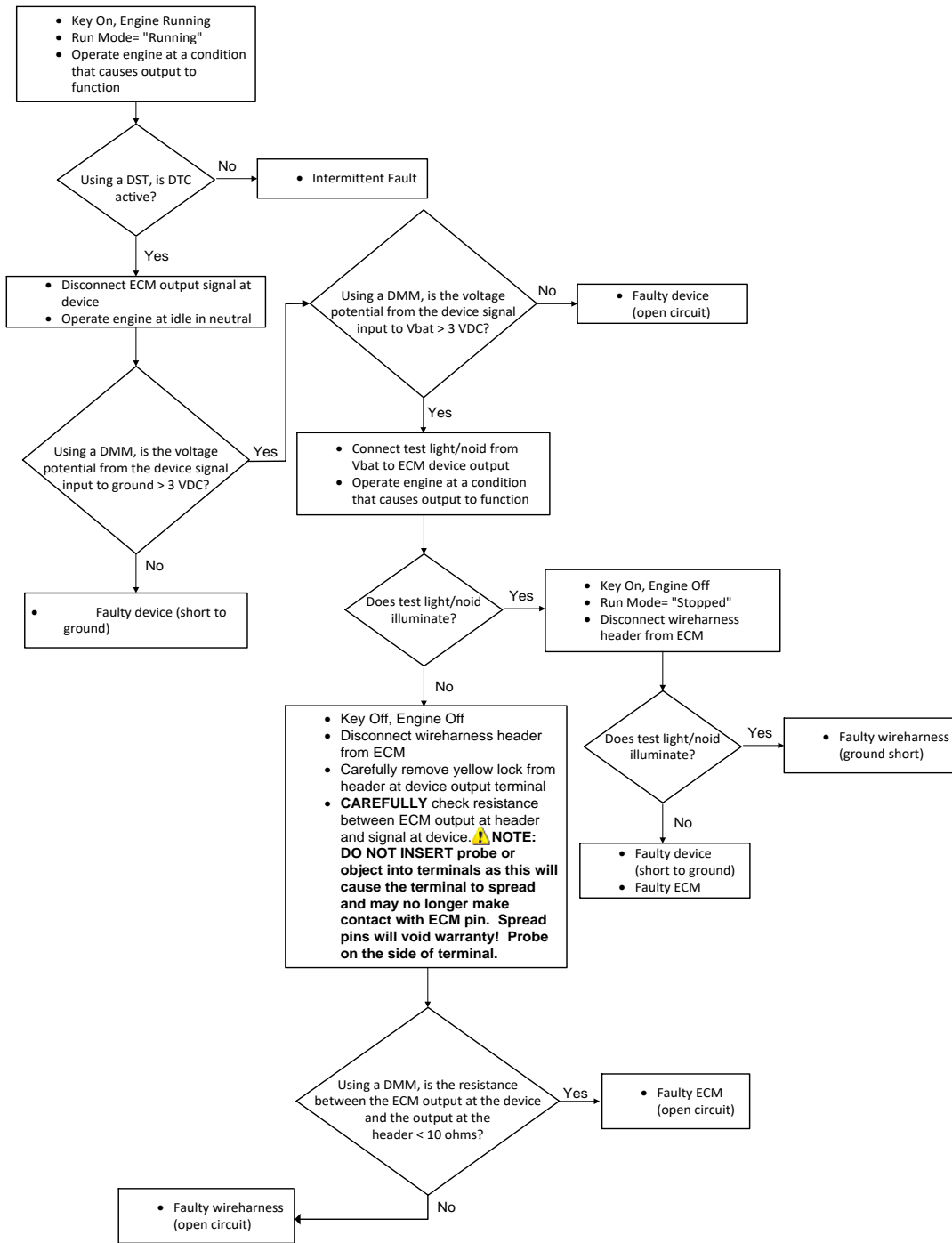

Code			Fault Description
DTC	SPN	FMI	
1632	697	3	PWM1-Gauge1 Short to Power
1634	698	3	PWM1-Gauge2 Short to Power
1636	699	3	PWM1-Gauge3 Short to Power

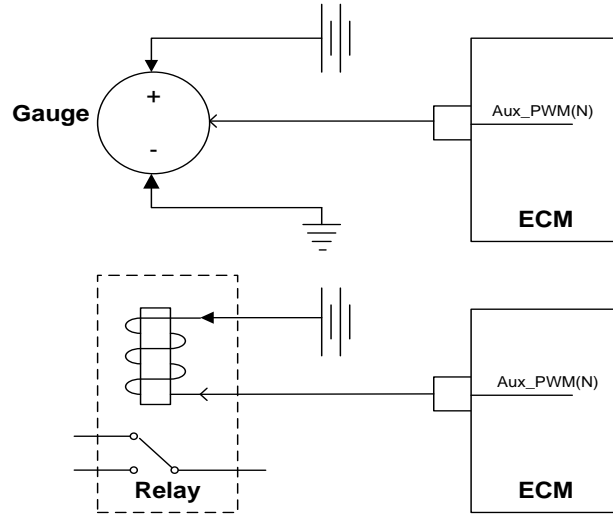

Hardware/Circuit:	Analog gauge, proportional actuator, on-off device (see examples above)
Hardware/Circuit Description:	<p>AUX_PWM(1-3) is an output that, depending on the ECM HW configuration, may be used to:</p> <ul style="list-style-type: none"> • Simulate the resistance of a sender to drive an analog gauge (Gauge driver config) • PWM an analog gauge (PWM config) • PWM the low-side of an on-off device (PWM config) • PWM a proportional actuator (PWM config)
Possible Causes:	AUX PWM output shorted to power source

DTC 1632-1634-1636: Troubleshooting Tree

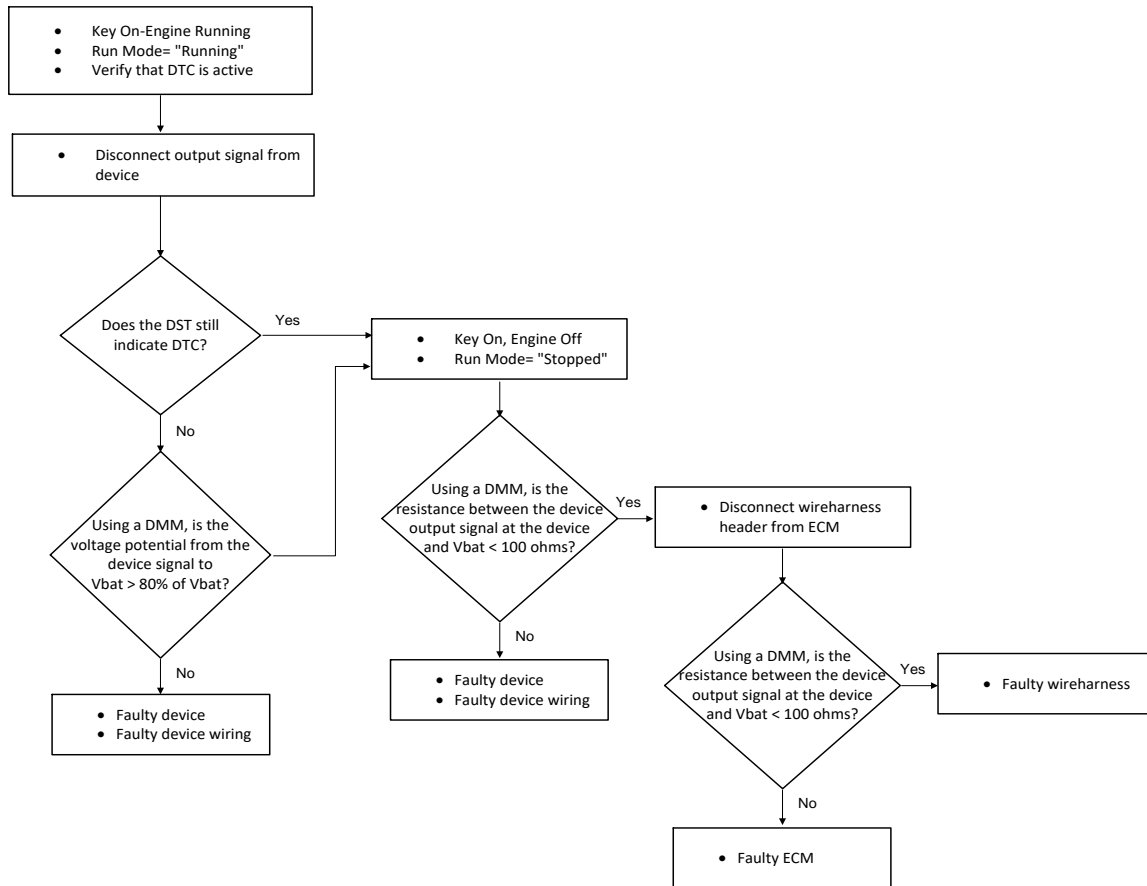

Code			Fault Description
DTC	SPN	FMI	
1641	920	4	Buzzer Control Ground Short

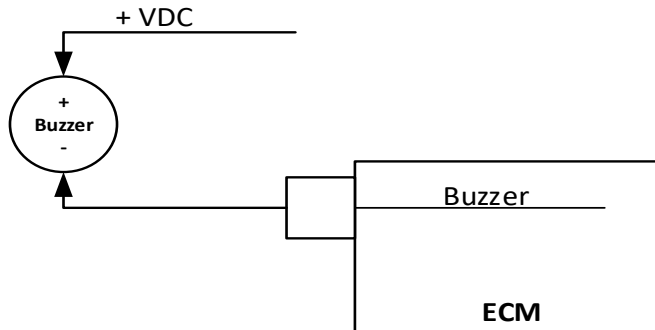

Hardware/Circuit:	Buzzer/Secondary warning device
--------------------------	---------------------------------

Hardware/Circuit Description:	This ECM output is used to provide a low-side switch to a secondary warning device such as an audible buzzer or secondary warning lamp.
--------------------------------------	---

Possible Causes:	ECM buzzer output shorted to ground
-------------------------	-------------------------------------

DTC 1641: Troubleshooting Tree

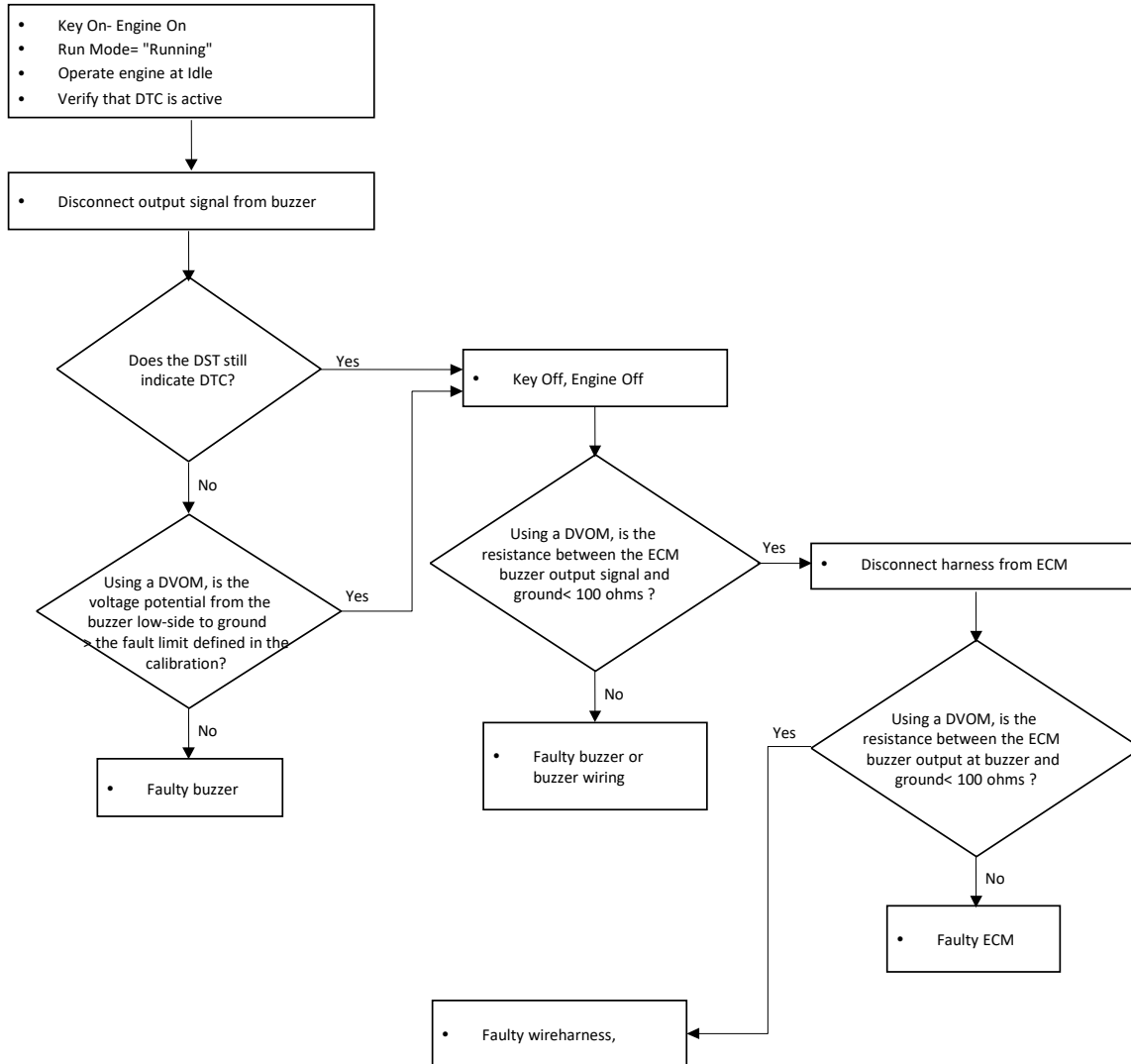

Code			Fault Description
DTC	SPN	FMI	
1642	920	5	Buzzer Open

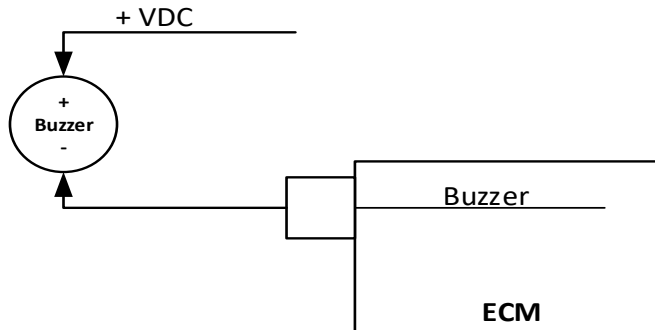

Hardware/Circuit:	Buzzer/Secondary warning device
--------------------------	---------------------------------

Hardware/Circuit Description:	This ECM output is used to provide a low-side switch to a secondary warning device such as an audible buzzer or secondary warning lamp.
--------------------------------------	---

Possible Causes:	ECM buzzer output open circuit
-------------------------	--------------------------------

DTC 1642: Troubleshooting Tree

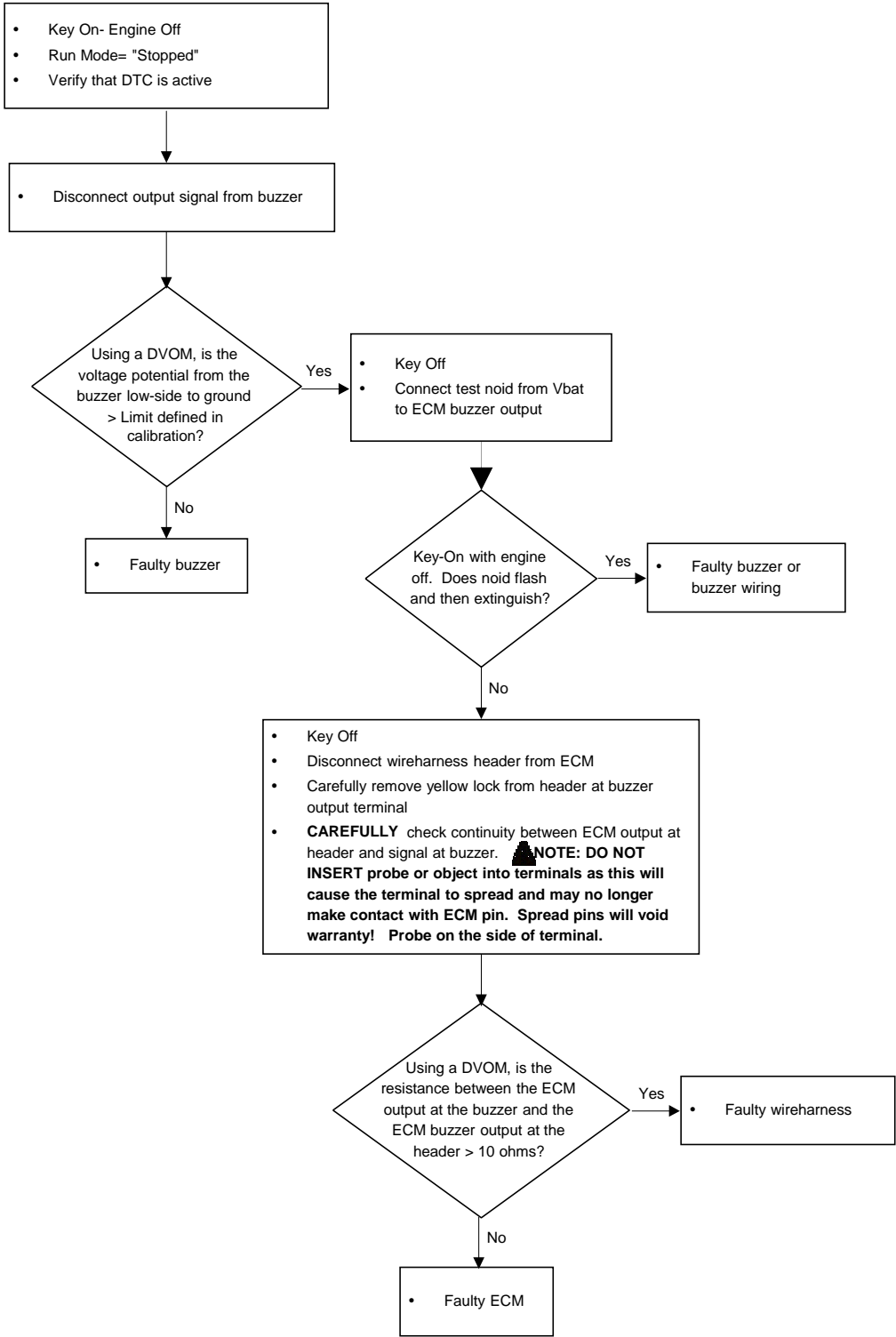

Code			Fault Description
DTC	SPN	FMI	
1643	920	3	Buzzer Short to Power

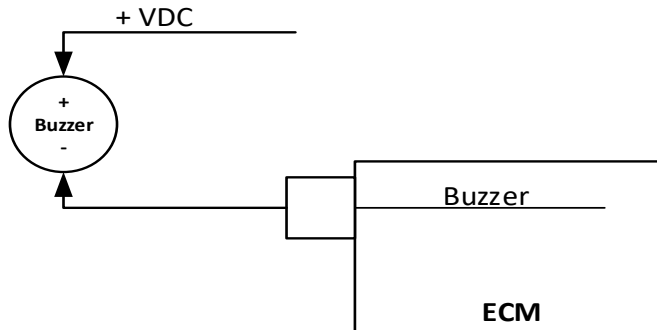

Hardware/Circuit:	Buzzer/Secondary warning device
--------------------------	---------------------------------

Hardware/Circuit Description:	This ECM output is used to provide a low-side switch to a secondary warning device such as an audible buzzer or secondary warning lamp.
--------------------------------------	---

Possible Causes:	ECM buzzer output shorted to power
-------------------------	------------------------------------

DTC 1643: Troubleshooting Tree

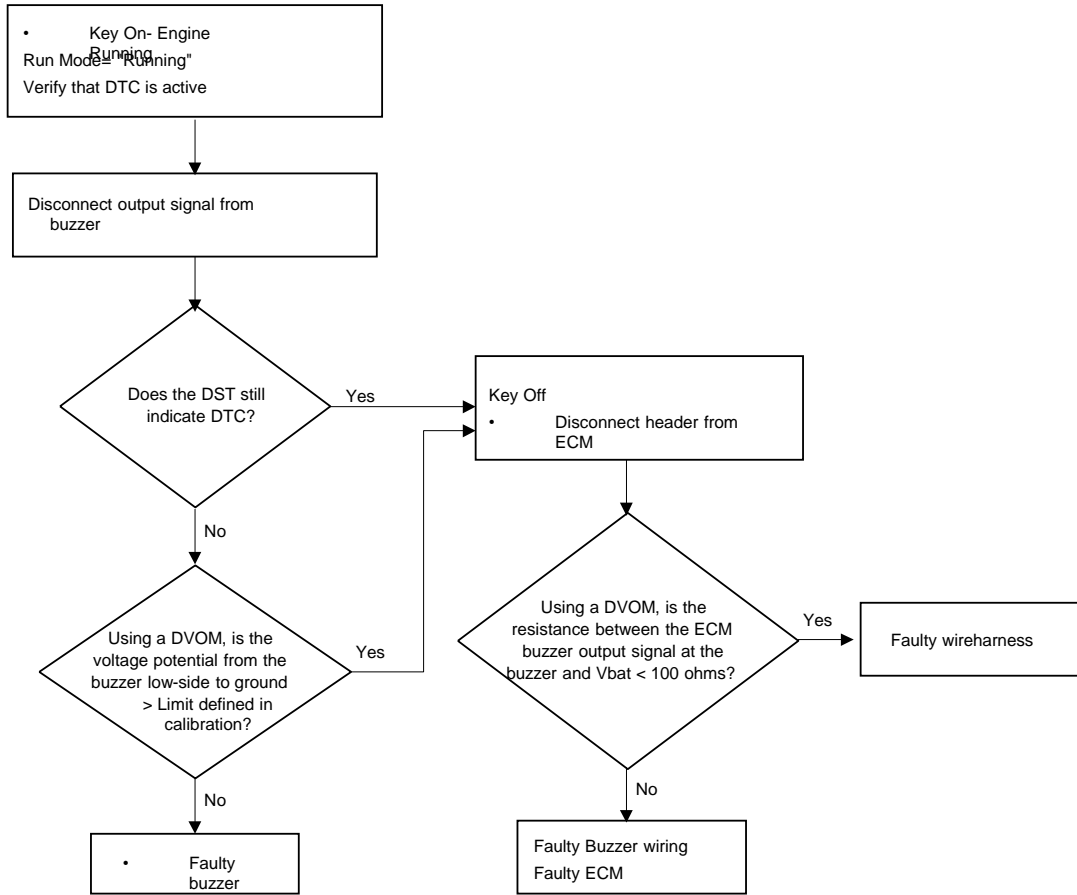

Code			Fault Description
DTC	SPN	FMI	
1644	1213	4	MIL Control Ground Short

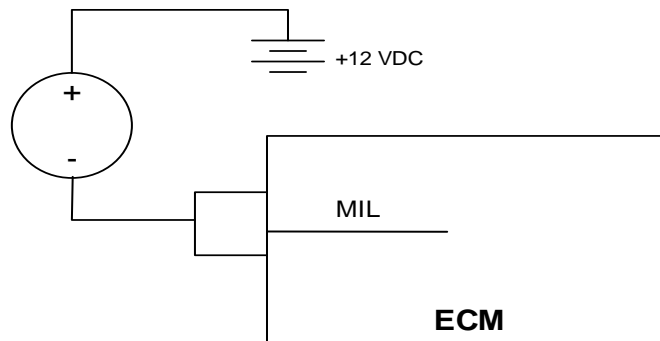

Hardware/Circuit:	MIL
--------------------------	-----

Hardware/Circuit Description:	This ECM output is used to provide a low-side switch to a MIL that is used to indicate that an emission related fault has been set.
--------------------------------------	---

Possible Causes:	This fault will set if the ECM detects that there is a ground short of the MIL output.
-------------------------	--

DTC 1644: Troubleshooting Tree

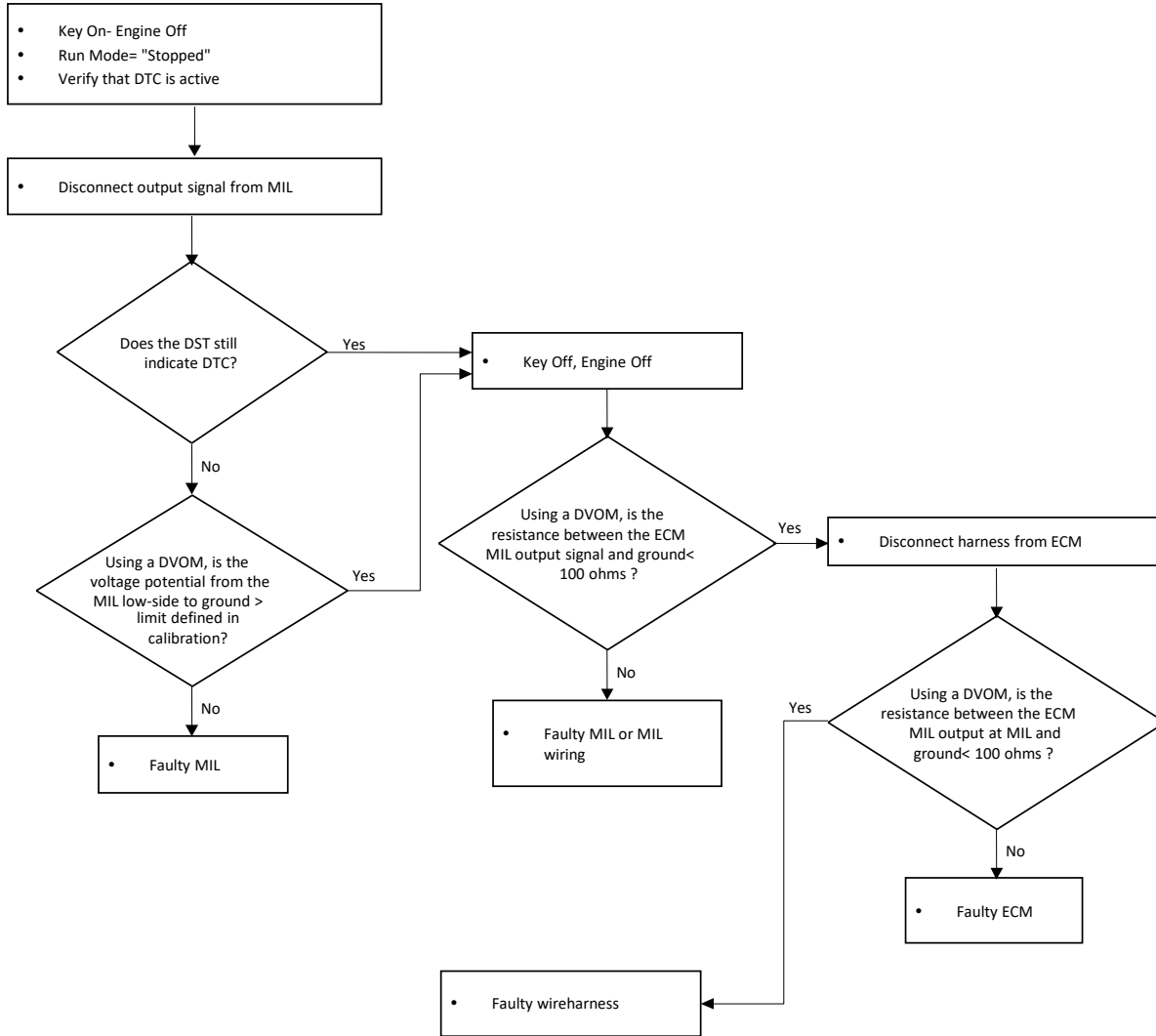

Code			Fault Description
DTC	SPN	FMI	
1645	1213	3	MIL Control Short to Power

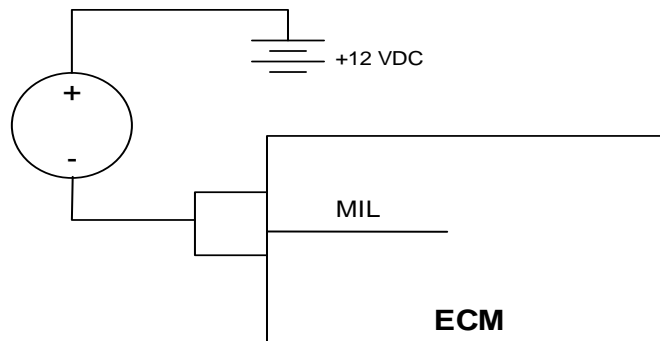

Hardware/Circuit:	MIL
--------------------------	-----

Hardware/Circuit Description:	This ECM output is used to provide a low-side switch to a MIL that is used to indicate that an emission related fault has been set.
--------------------------------------	---

Possible Causes:	This fault will set if the ECM detects that the ECM MIL output shorted to power.
-------------------------	--

DTC 1645: Troubleshooting Tree

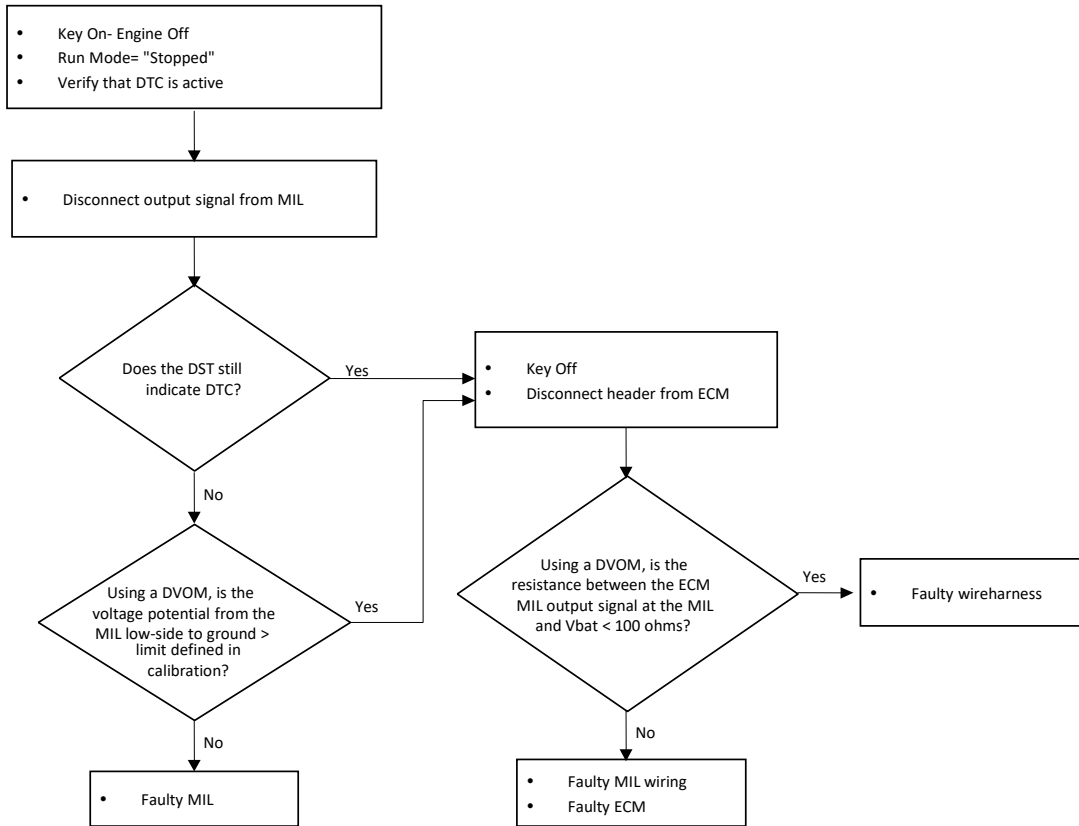

Code			Fault Description
DTC	SPN	FMI	
2111	51	7	Unable to Reach Lower TPS

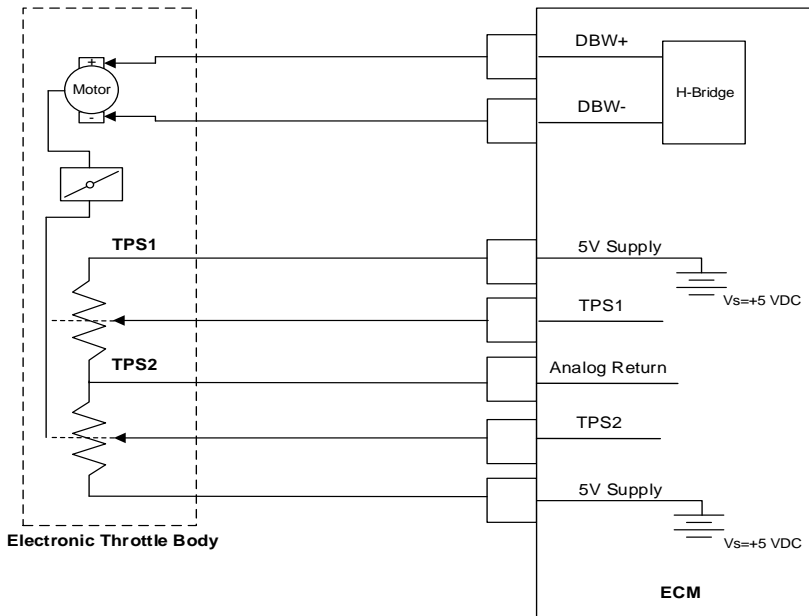

Hardware/Circuit:	Throttle Position Sensor
--------------------------	--------------------------

Hardware/Circuit Description:	There are 2 Throttle Position Sensors located within the throttle which use variable resistors to determine signal voltage based on throttle plate position. TPS1 will read low voltage when closed and TPS2 will read high voltage when closed. The TPS1 and TPS2 percentages are calculated from these voltages. Although the voltages are different, the calculated values for the throttle position percentages should be very close to the same. The TPS values are used by the ECM to determine if the throttle is opening as commanded.
--------------------------------------	--

Possible Causes:	This fault will set if the throttle command is 20% less than the actual throttle position. During this active fault the MIL light will be on and the engine will shut down.
-------------------------	---

DTC 2111: Troubleshooting Tree

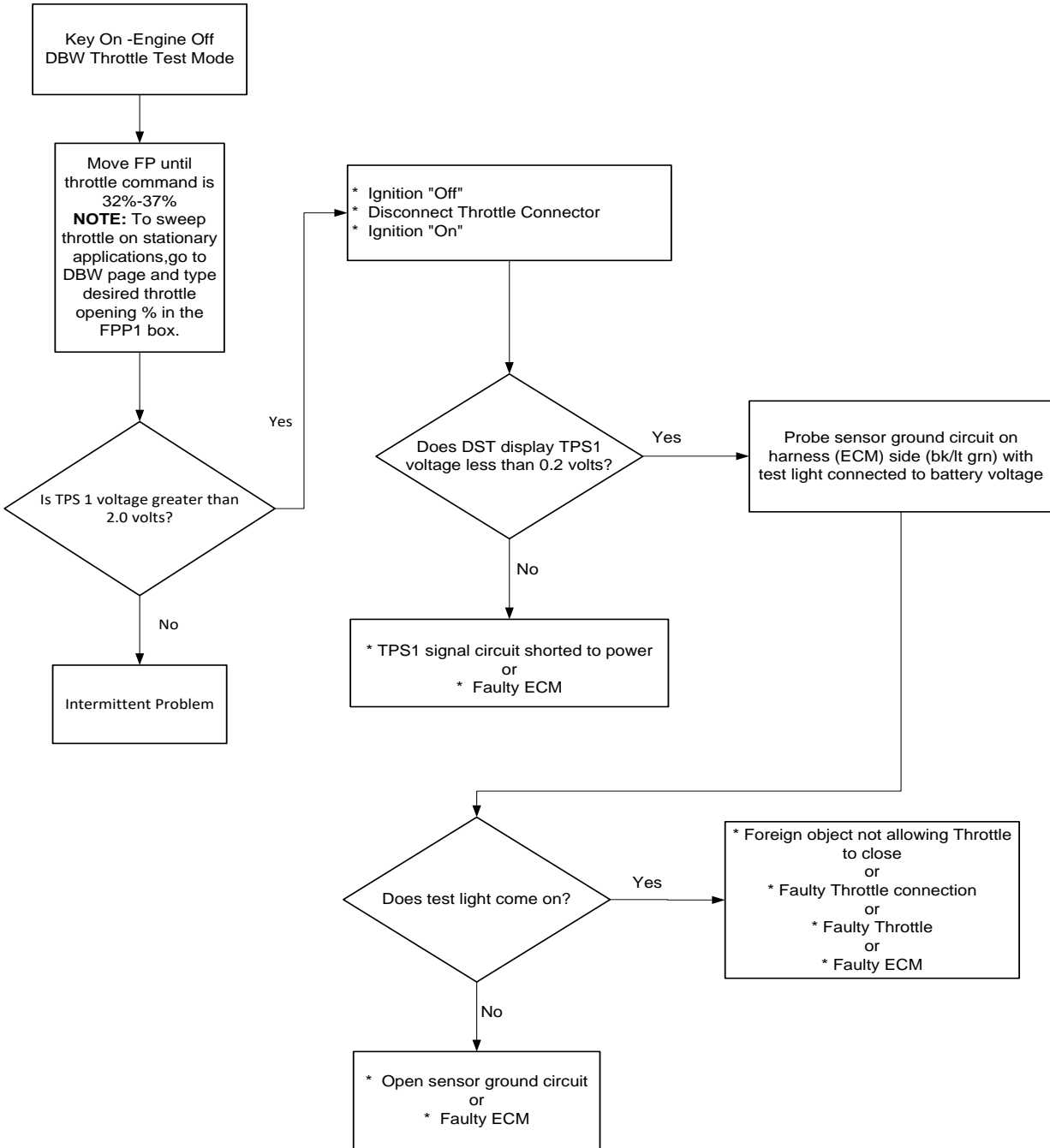

Code			Fault Description
DTC	SPN	FMI	
2112	51	7	Unable to Reach Higher TPS

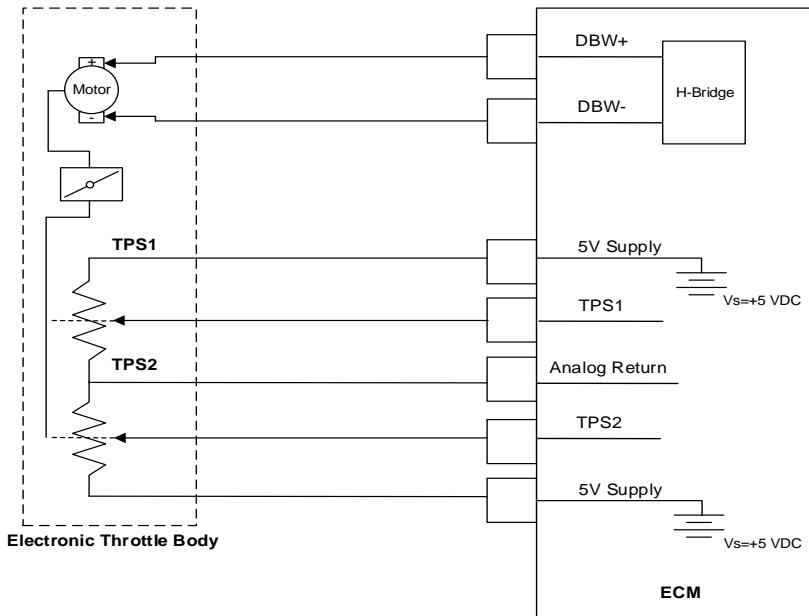

Hardware/Circuit:	Throttle Position Sensor
--------------------------	--------------------------

Hardware/Circuit Description:	There are 2 Throttle Position Sensors located within the throttle which use variable resistors to determine signal voltage based on throttle plate position. TPS1 will read low voltage when closed and TPS2 will read high voltage when closed. The TPS1 and TPS2 percentages are calculated from these voltages. Although the voltages are different, the calculated values for the throttle position percentages should be very close to the same. The TPS values are used by the ECM to determine if the throttle is opening as commanded.
--------------------------------------	--

Possible Causes:	This fault will set if the throttle command is 20% or more than the actual throttle position. During this active fault the MIL light will be on and the engine will shut down..
-------------------------	---

Code			Fault Description
DTC	SPN	FMI	
2115	91	0	FPP1 Higher than IVS Limit

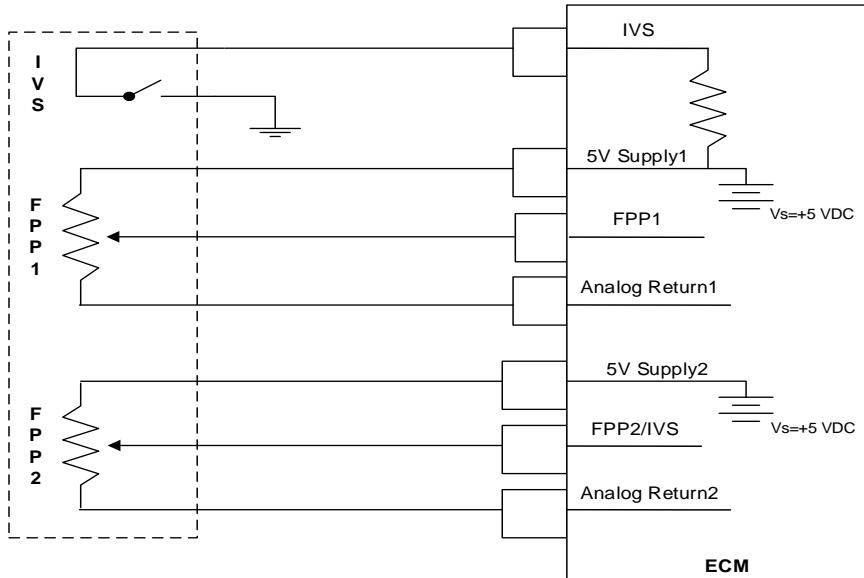

Hardware/Circuit:	Foot Pedal Position / Idle Validation Switch
--------------------------	--

Hardware/Circuit Description:	The engine load command to the ECM is determined by operator depression of the electronic foot pedal. The ECM monitors the foot pedal position and controls the throttle to maintain the commanded power level. Because a problem with the foot pedal signal can result in a higher or lower power than intended by the operator, the pedal used with this control system incorporates a sensor with an idle validation switch. Checks and cross checks are constantly conducted by the ECM to determine the validity of the signals. The Idle Validation Switch (IVS) is a normally open contact (idle) that grounds (closed contacts) the IVS circuit to the ECM when the pedal is depressed more than the idle position.
--------------------------------------	---

Possible Causes:	This fault will set if the IVS is at idle (open) and the FPP voltage is greater than the fault limit defined in the calibration.
-------------------------	--

DTC 2115: Troubleshooting Tree

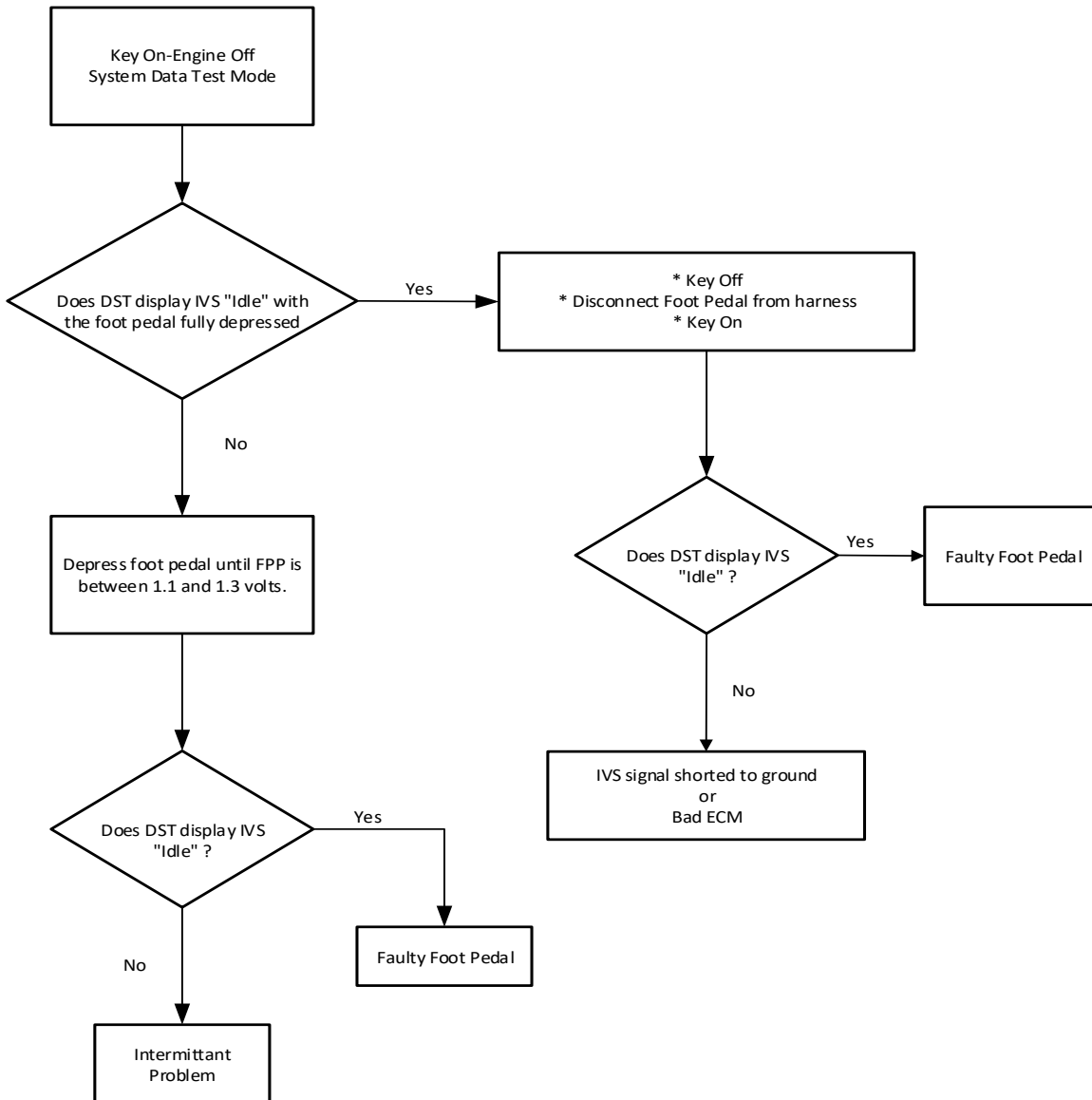

Code			Fault Description
DTC	SPN	FMI	
2116	29	0	FPP2 Higher than IVS Limit

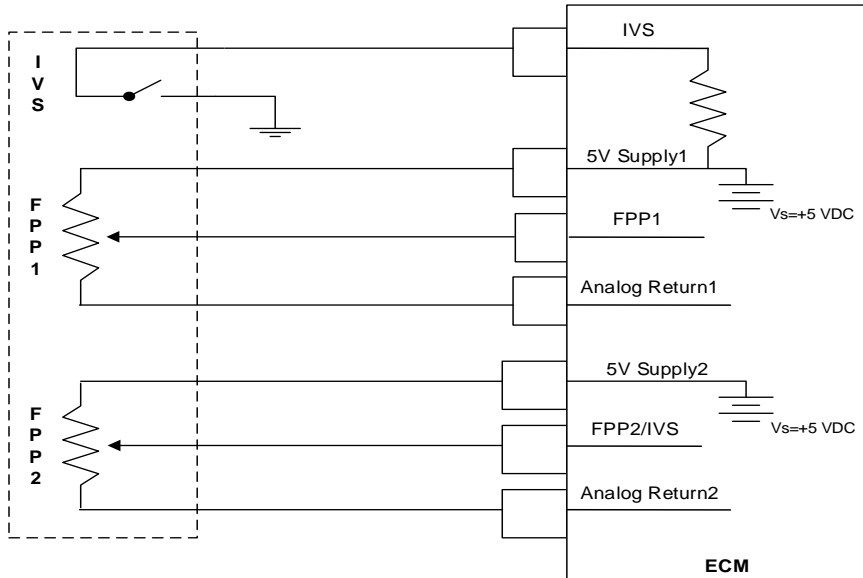

Hardware/Circuit:	Foot Pedal Position / Idle Validation Switch
--------------------------	--

Hardware/Circuit Description:	The engine load command to the ECM is determined by operator depression of the electronic foot pedal. The ECM monitors the foot pedal position and controls the throttle to maintain the commanded power level. Because a problem with the foot pedal signal can result in a higher or lower power than intended by the operator, the pedal used with this control system incorporates a sensor with an idle validation switch. Checks and cross checks are constantly conducted by the ECM to determine the validity of the signals. The Idle Validation Switch (IVS) is a normally open contact (idle) that grounds (closed contacts) the IVS circuit to the ECM when the pedal is depressed more than the idle position.
--------------------------------------	---

Possible Causes:	This fault will set if the IVS is at idle (open) and the FPP voltage is greater than the fault limit defined in the calibration.
-------------------------	--

DTC 2116: Troubleshooting Tree

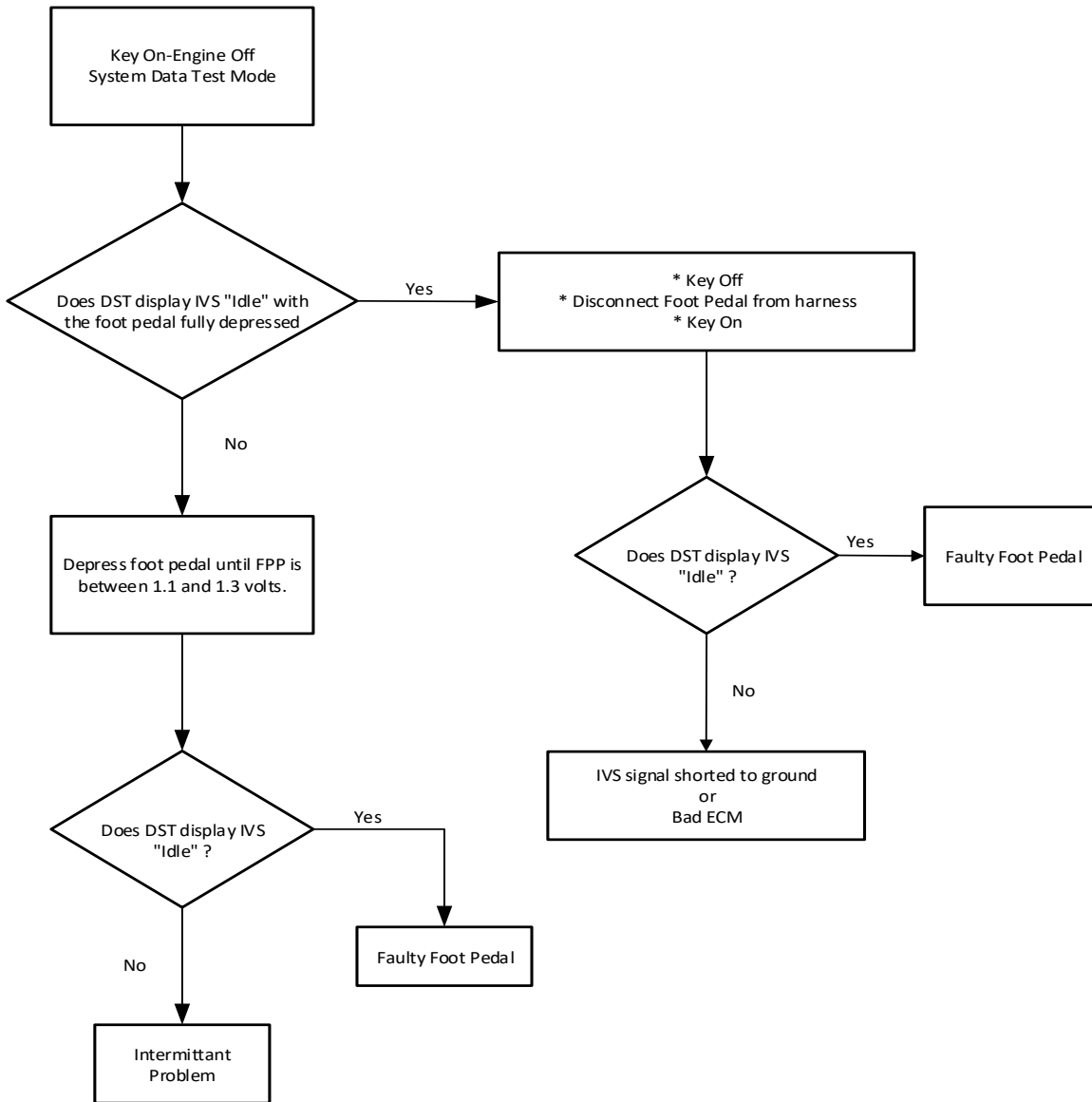

Code			Fault Description
DTC	SPN	FMI	
2120	520199	11	FPP1 invalid voltage and FPP2 disagrees with IVS

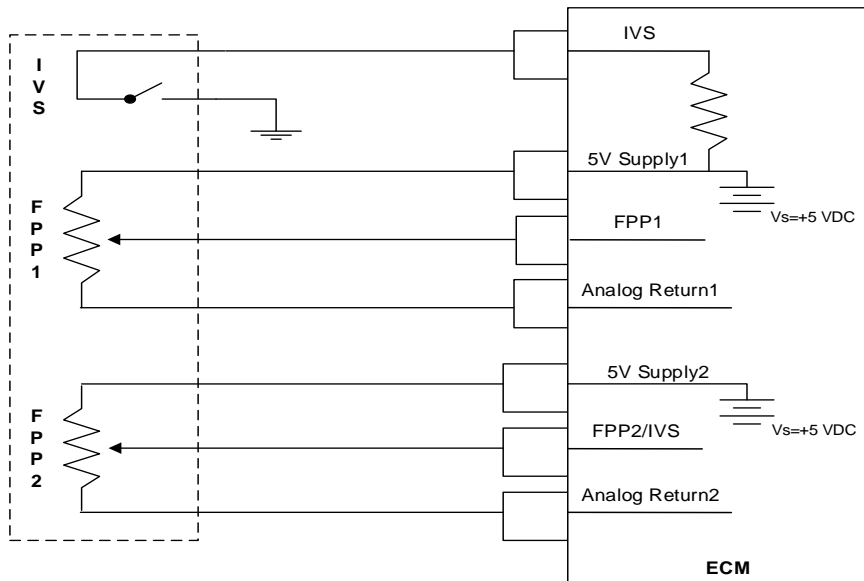

Hardware/Circuit:	Foot Pedal Position / Idle Validation Switch
--------------------------	--

Hardware/Circuit Description:	The engine load command to the ECM is determined by operator depression of the electronic foot pedal. The ECM monitors the foot pedal position and controls the throttle to maintain the commanded power level. Because a problem with the foot pedal signal can result in a higher or lower power than intended by the operator, the pedal used with this control system incorporates a sensor with an idle validation switch. Checks and cross checks are constantly conducted by the ECM to determine the validity of the signals. The Idle Validation Switch (IVS) is a normally open contact (idle) that grounds (closed contacts) the IVS circuit to the ECM when the pedal is depressed more than the idle position.
--------------------------------------	---

Possible Causes:	This fault is only applicable with dual potentiometer/single IVS sensors and indicates that FPP1 voltage is out-of-range and FPP2 does not correlate with the IVS state resulting in a loss of redundancy.
-------------------------	--

DTC 2120: Troubleshooting Tree

- Troubleshoot FPP1 voltage out-of-range following DTC 2122 and 2123 procedures.
- Troubleshoot FPP2 disagrees with IVS following DTC 2116 and 2140 procedures.

Code			Fault Description
DTC	SPN	FMI	
2121	91	18	FPP1 Lower than FPP2

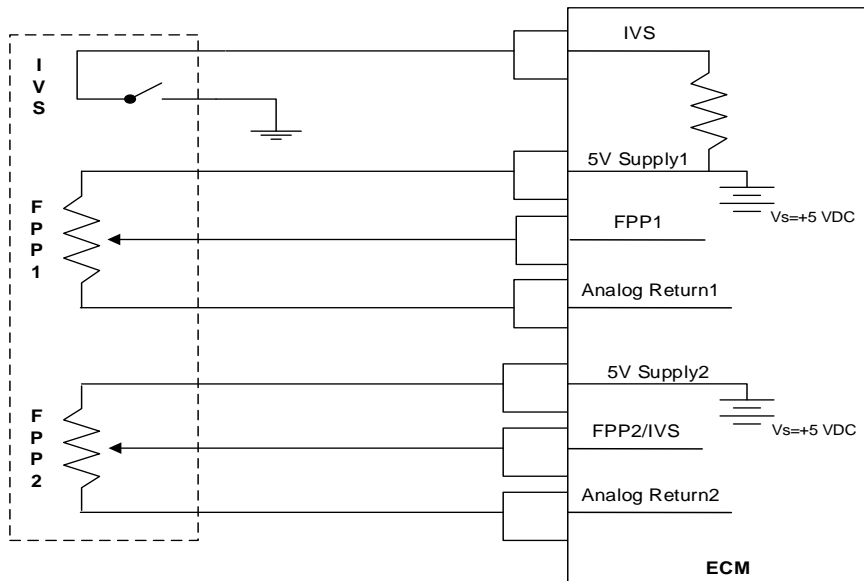

Hardware/Circuit:	Foot Pedal Position
--------------------------	---------------------

Hardware/Circuit Description:	<p>The FPP sensor is an electronic device that is coupled to a mechanically driven input as commanded by the vehicle/engine operator. A FPP sensor may be, but is not limited to a foot pedal assembly, a cable-lever-sensor assembly, or a rotary potentiometer. General sensor configurations consist of single potentiometer with IVS, two potentiometers, or two potentiometers with IVS. The FPP sensor outputs are proportional to the commanded input. The ECM uses the FPP sensor inputs to control the throttle and adjust the engine's load in order to achieve the requested power. Since the FPP sensor inputs directly affect the engine's power output, redundant sensors are generally used to ensure safe, reliable operation.</p>
--------------------------------------	--

Possible Causes:	This fault indicates that the measured % deflection of sensor 1 is less than sensor 2 by an amount defined in calibration.
-------------------------	--

DTC 2121: Troubleshooting Tree

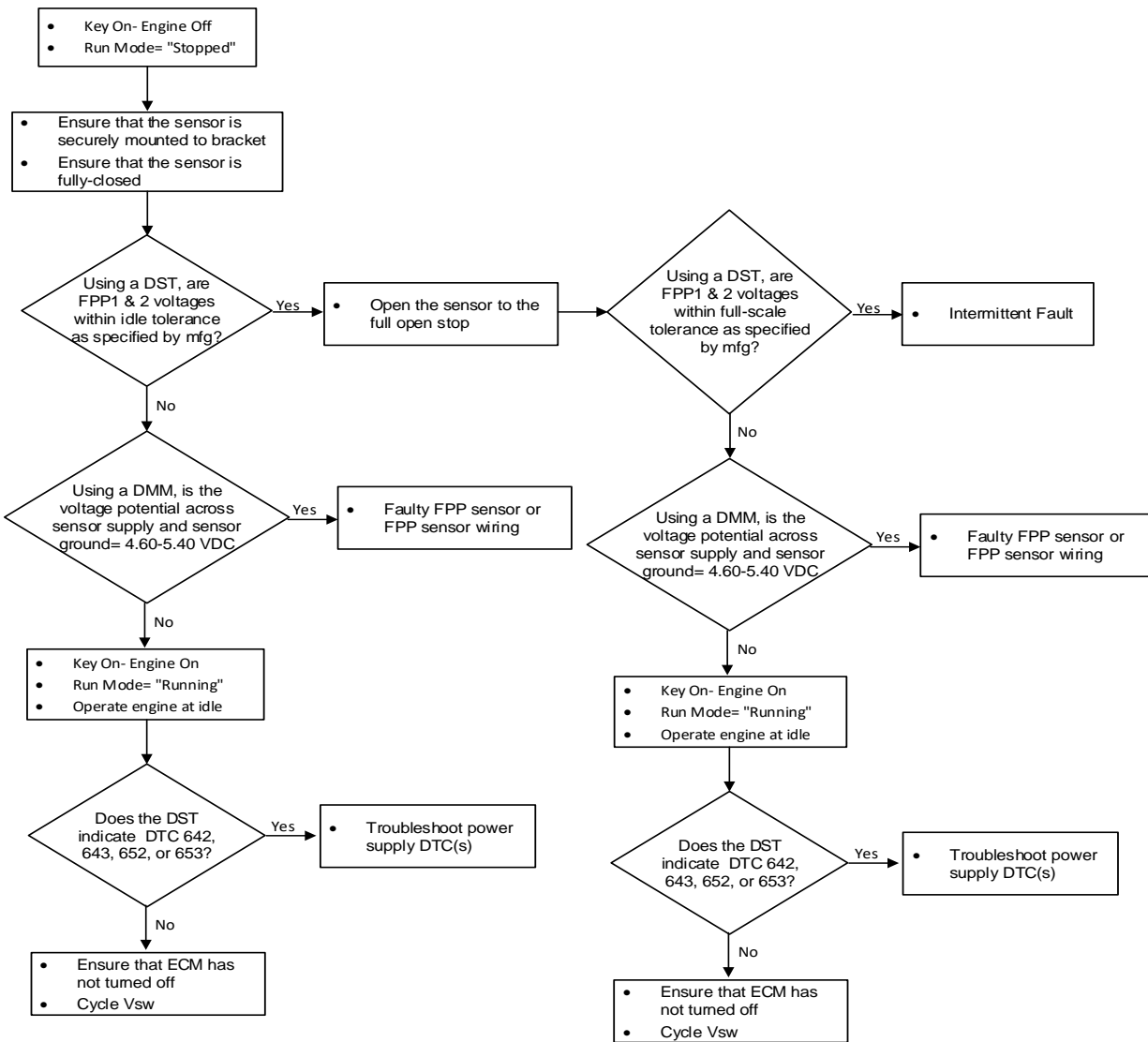

Code			Fault Description
DTC	SPN	FMI	
2122	91	4	FPP1 Low Voltage
2127	29	4	FPP2 Low Voltage

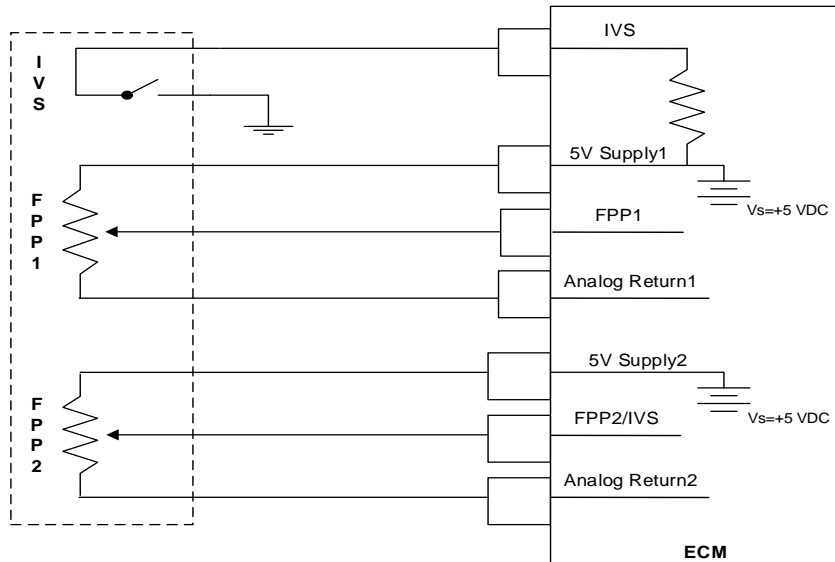

Hardware/Circuit:	Foot Pedal Position
--------------------------	---------------------

Hardware/Circuit Description:	<p>The FPP sensor is an electronic device that is coupled to a mechanically driven input as commanded by the vehicle/engine operator. A FPP sensor may be, but is not limited to a foot pedal assembly, a cable-lever-sensor assembly, or a rotary potentiometer. General sensor configurations consist of single potentiometer/hall-effect with IVS, two potentiometers/hall-effects, or two potentiometers/hall-effects with IVS. The FPP sensor outputs are proportional to the commanded input. The ECM uses the FPP sensor input(s) to control the throttle and adjust the engine's load in order to achieve the requested power. Since the FPP sensor inputs directly affect the engine's power output, redundant sensors are generally used to ensure safe, reliable operation. In systems that utilize a mechanical throttle the foot pedal input is used to monitor the position of the mechanical throttle valve in order to activate minimum or maximum governors. In electronic throttle control systems the foot pedal position/throttle control position sensor is used by the engine/equipment operator or system to command either throttle position or a governor speed target proportional to the input in order to achieve desired system behavior.</p>
--------------------------------------	--

Possible Causes:	<p>This fault will set if FPP1/FPP2 voltage is lower than the limit defined in the engine calibration at any operating condition. Fully redundant systems (when three sensors are compared) limited operation may result in setting codes without requiring derates, however, single or non-redundant systems (FPP w/IVS) must command forced idle or engine shutdowns depending on the type of system.</p>
-------------------------	---

DTC 2122-2127: Troubleshooting Tree

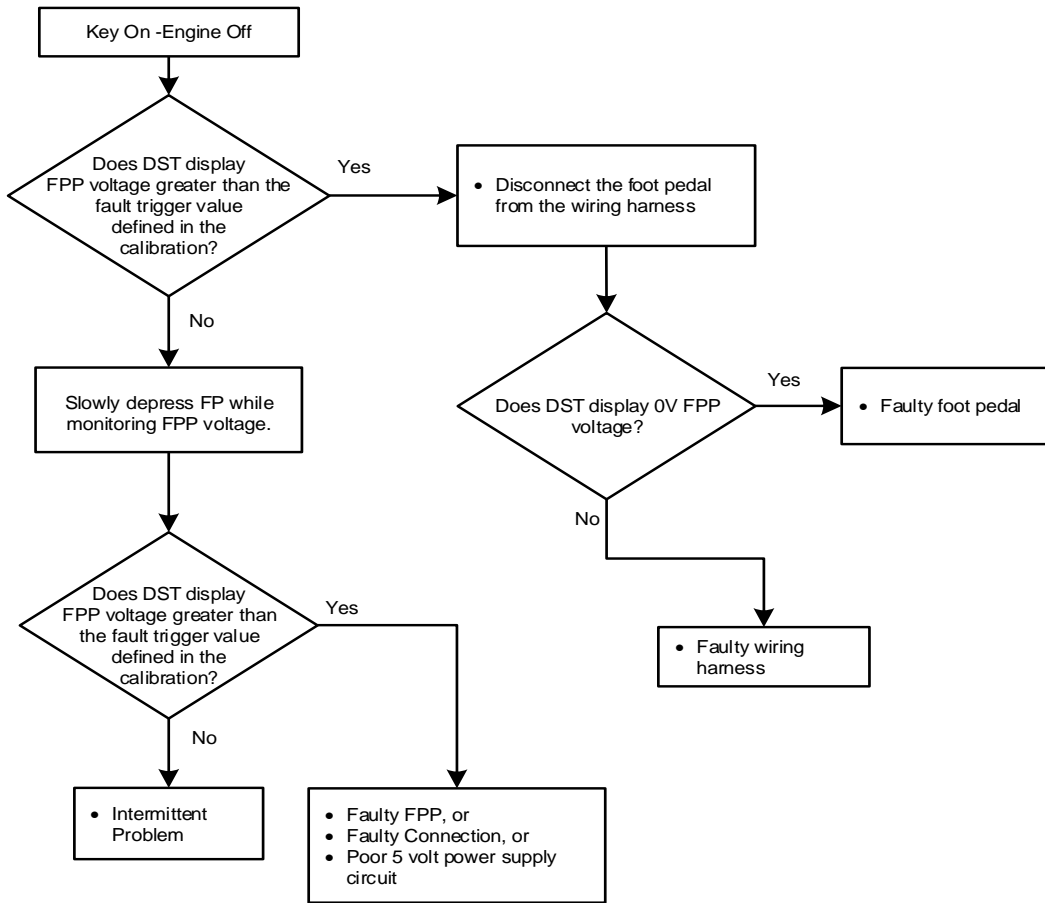

Code			Fault Description
DTC	SPN	FMI	
2123	91	3	FPP1 High Voltage
2128	29	3	FPP2 High Voltage

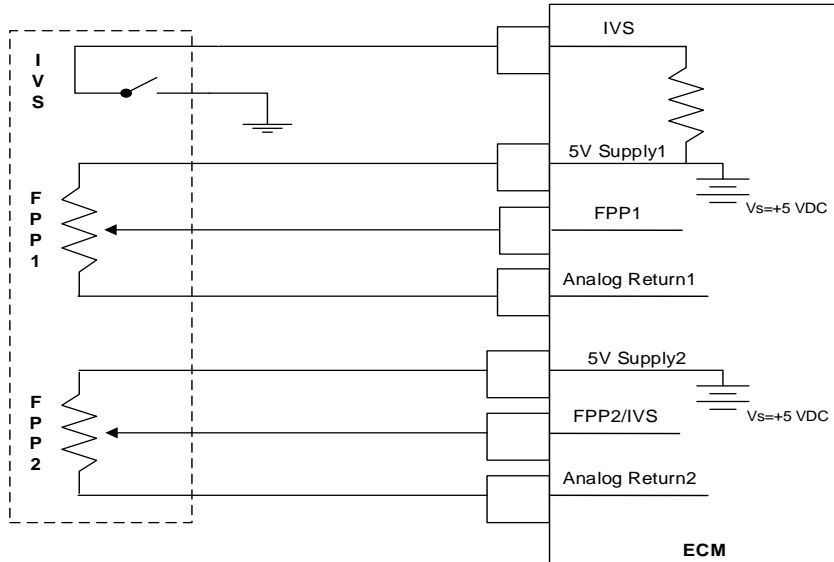

Hardware/Circuit:	Foot Pedal Position
--------------------------	---------------------

Hardware/Circuit Description:	<p>The FPP sensor is an electronic device that is coupled to a mechanically driven input as commanded by the vehicle/engine operator. A FPP sensor may be, but is not limited to a foot pedal assembly, a cable-lever-sensor assembly, or a rotary potentiometer. General sensor configurations consist of single potentiometer/hall-effect with IVS, two potentiometers/hall-effects, or two potentiometers/hall-effects with IVS. The FPP sensor outputs are proportional to the commanded input. The ECM uses the FPP sensor input(s) to control the throttle and adjust the engine's load in order to achieve the requested power. Since the FPP sensor inputs directly affect the engine's power output, redundant sensors are generally used to ensure safe, reliable operation. In systems that utilize a mechanical throttle the foot pedal input is used to monitor the position of the mechanical throttle valve in order to activate minimum or maximum governors. In electronic throttle control systems the foot pedal position/throttle control position sensor is used by the engine/equipment operator or system to command either throttle position or a governor speed target proportional to the input in order to achieve desired system behavior.</p>
--------------------------------------	--

Possible Causes:	<p>This fault will set if FPP1 voltage is higher than the limit defined in the engine calibration at any operating condition. Fully redundant systems (when three sensors are compared) limited operation may result in setting codes without requiring derates, however, single or non-redundant systems (FPP1 w/IVS) must command forced idle or engine shutdowns depending on the type of system.</p>
-------------------------	--

DTC 2123-2128: Troubleshooting Tree

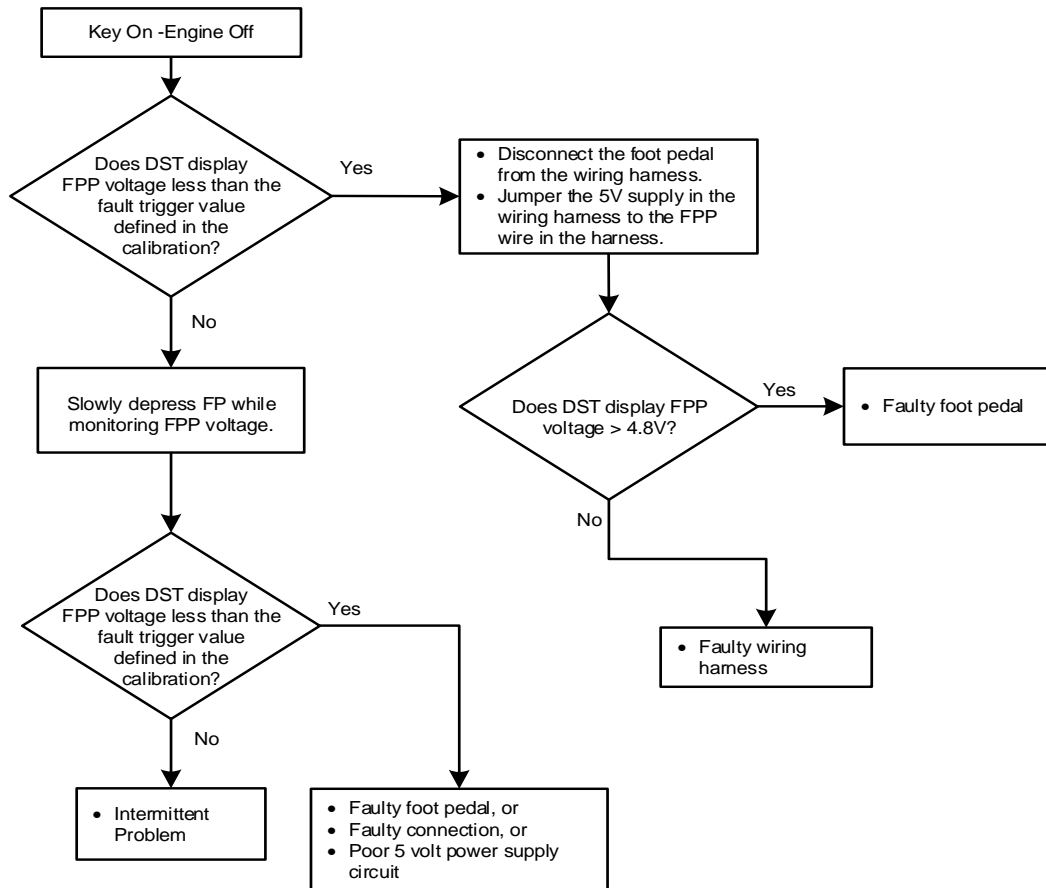

Code			Fault Description
DTC	SPN	FMI	
2125	520199	11	FPP2 Invalid Voltage and FPP1 Disagrees with IVS

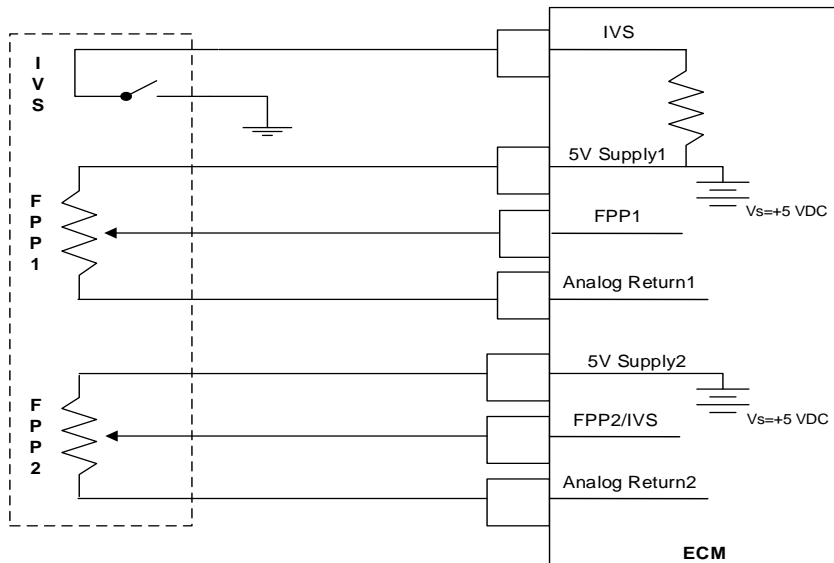

Hardware/Circuit:	Electronic foot pedal/throttle control sensor
--------------------------	---

Hardware/Circuit Description:	<p>The FPP sensor is an electronic device that is coupled to a mechanically driven input as commanded by the vehicle/engine operator. A FPP sensor may be, but is not limited to a foot pedal assembly, a cable-lever-sensor assembly, or a rotary potentiometer. General sensor configurations consist of single potentiometer with IVS, two potentiometers, or two potentiometers with IVS. The FPP sensor outputs are proportional to the commanded input. The ECM uses the FPP sensor inputs to control the throttle and adjust the engine's load in order to achieve the requested power. Since the FPP sensor inputs directly affect the engine's power output, redundant sensors are generally used to ensure safe, reliable operation.</p>
--------------------------------------	--

Possible Causes:	<p>This fault is only applicable with dual potentiometer/single IVS sensors and indicates that FPP2 voltage is out-of-range and FPP1% does not correlate with the IVS state resulting in a loss of redundancy.</p>
-------------------------	--

DTC 2125: Diagnostic Aid

- Troubleshoot FPP2 voltage out-of-range following DTC 2127 and 2128 procedures.
- Troubleshoot FPP1 disagrees with IVS following DTC 2115 and 2139 procedures.

Code			Fault Description
DTC	SPN	FMI	
2126	91	16	FPP1 Higher than FPP2

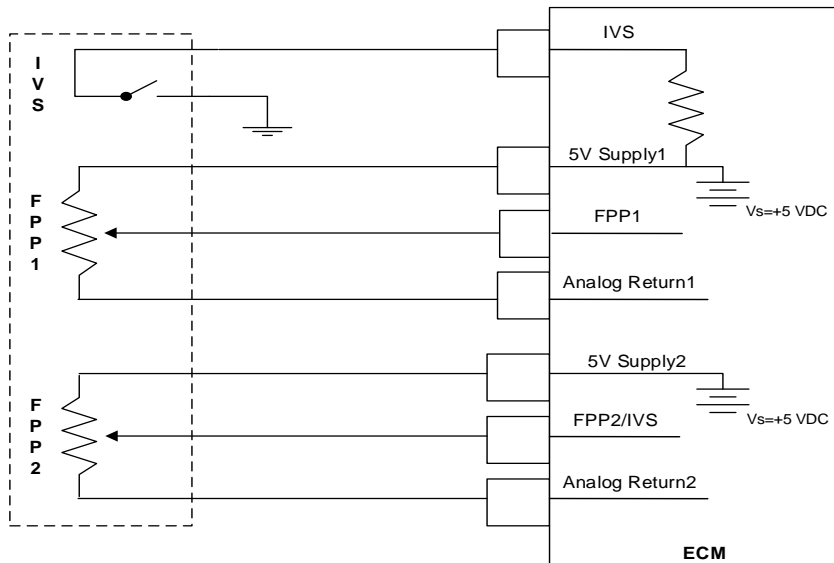

Hardware/Circuit:	Electronic foot pedal/throttle control sensor
--------------------------	---

Hardware/Circuit Description:	<p>The FPP sensor is an electronic device that is coupled to a mechanically driven input as commanded by the vehicle/engine operator. A FPP sensor may be, but is not limited to a foot pedal assembly, a cable-lever-sensor assembly, or a rotary potentiometer. General sensor configurations consist of single potentiometer with IVS, two potentiometers, or two potentiometers with IVS. The FPP sensor outputs are proportional to the commanded input. The ECM uses the FPP sensor inputs to control the throttle and adjust the engine's load in order to achieve the requested power. Since the FPP sensor inputs directly affect the engine's power output, redundant sensors are generally used to ensure safe, reliable operation.</p>
--------------------------------------	--

Possible Causes:	This fault indicates that the measured % deflection of sensor 1 is greater than sensor 2 by an amount defined in calibration.
-------------------------	---

DTC 2126: Troubleshooting Tree

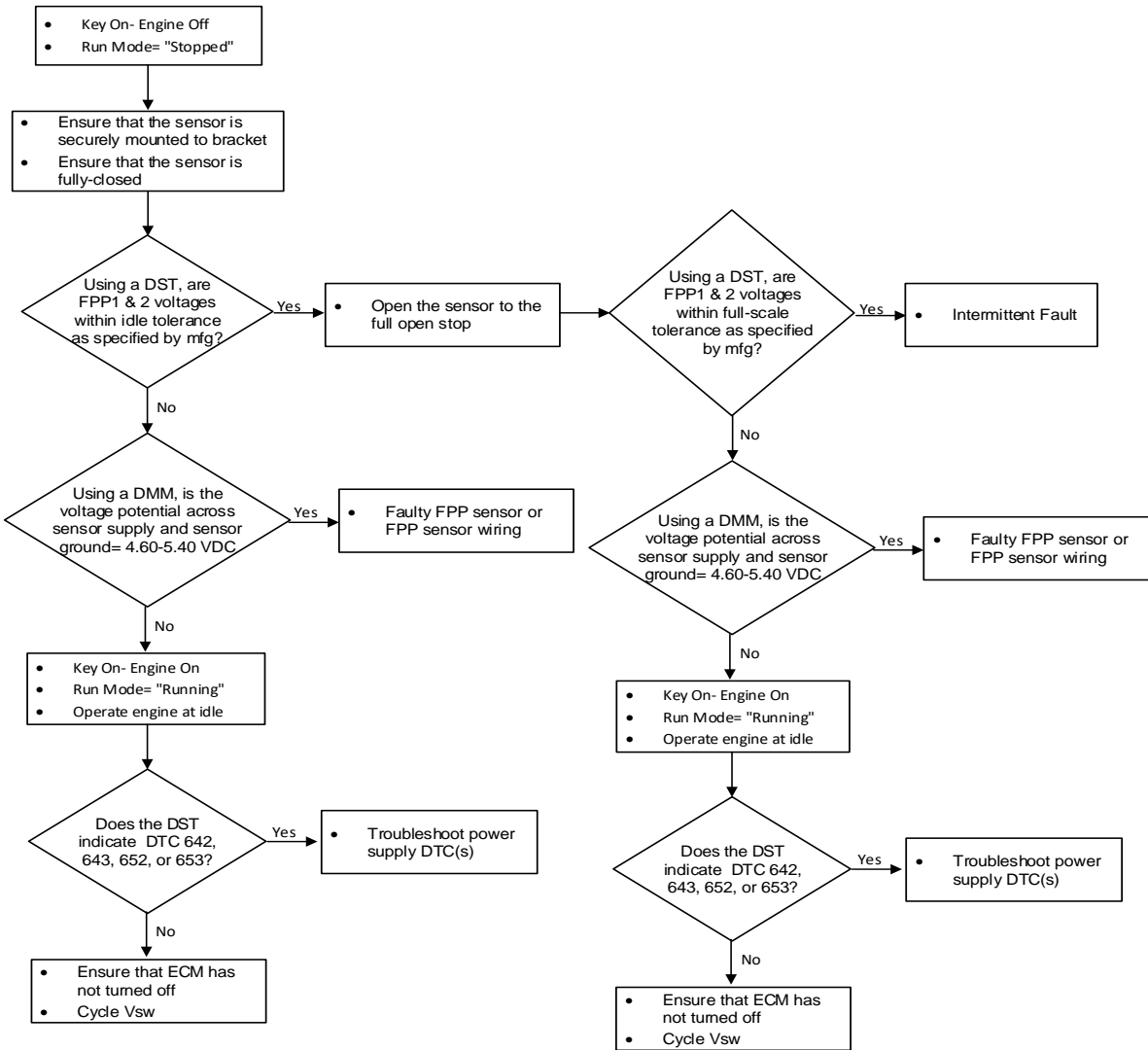

Code			Fault Description
DTC	SPN	FMI	
2130	558	5	IVS Stuck at-idle, FPP1/2 match

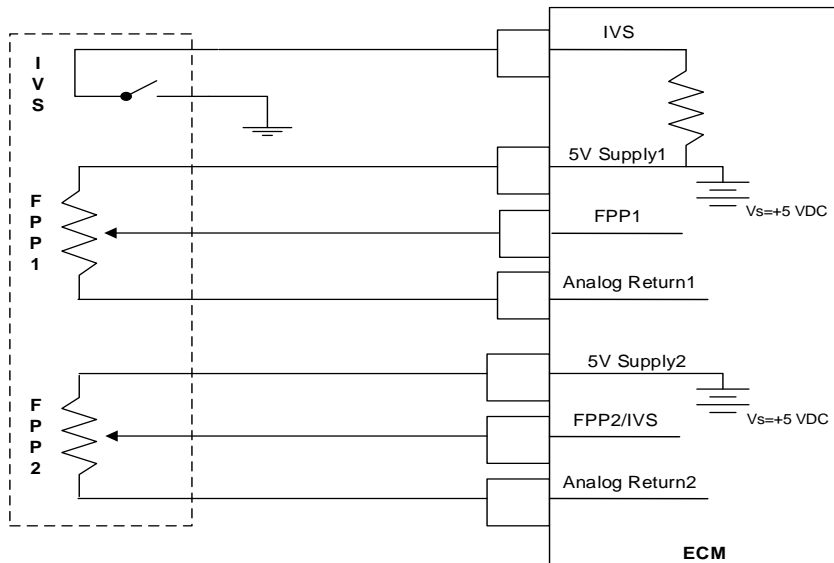

Hardware/Circuit:	Electronic foot pedal/throttle control sensor
--------------------------	---

Hardware/Circuit Description:	<p>The FPP sensor is an electronic device that is coupled to a mechanically driven input as commanded by the vehicle/engine operator. A FPP sensor may be, but is not limited to a foot pedal assembly, a cable-lever-sensor assembly, or a rotary potentiometer. General sensor configurations consist of single potentiometer with IVS, two potentiometers, or two potentiometers with IVS. The FPP sensor outputs are proportional to the commanded input. The ECM uses the FPP sensor inputs to control the throttle and adjust the engine's load in order to achieve the requested power. Since the FPP sensor inputs directly affect the engine's power output, redundant sensors are generally used to ensure safe, reliable operation.</p>
--------------------------------------	--

Possible Causes:	This fault is only applicable with dual potentiometer/single IVS sensors and indicates that the two FPP percentages correlate and register an off-idle condition but the IVS state reads at idle throughout entire operating range.
-------------------------	---

DTC 2130: Troubleshooting Tree

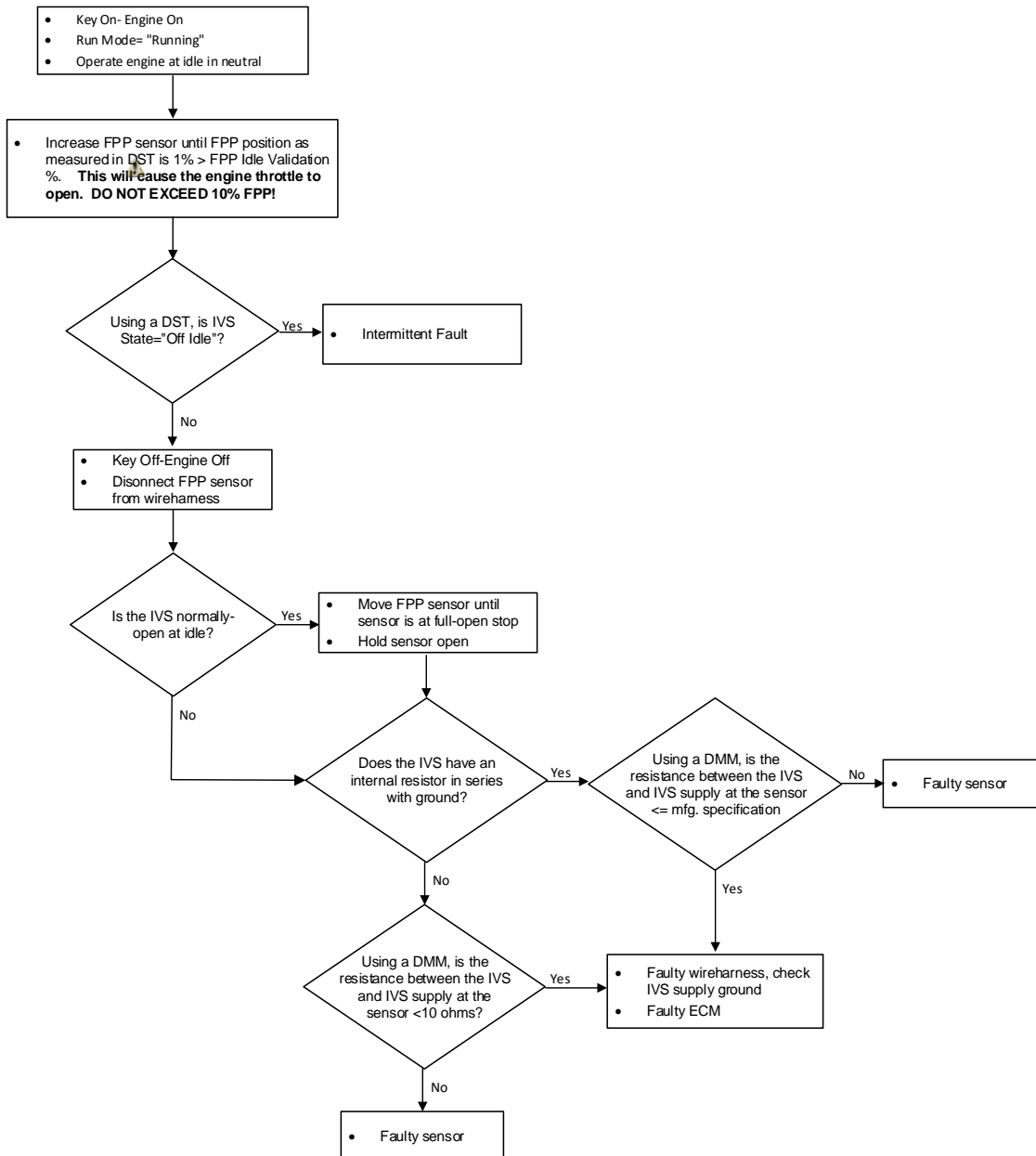

Code			Fault Description
DTC	SPN	FMI	
2131	558	6	IVS Stuck off-idle, FPP1/2 match

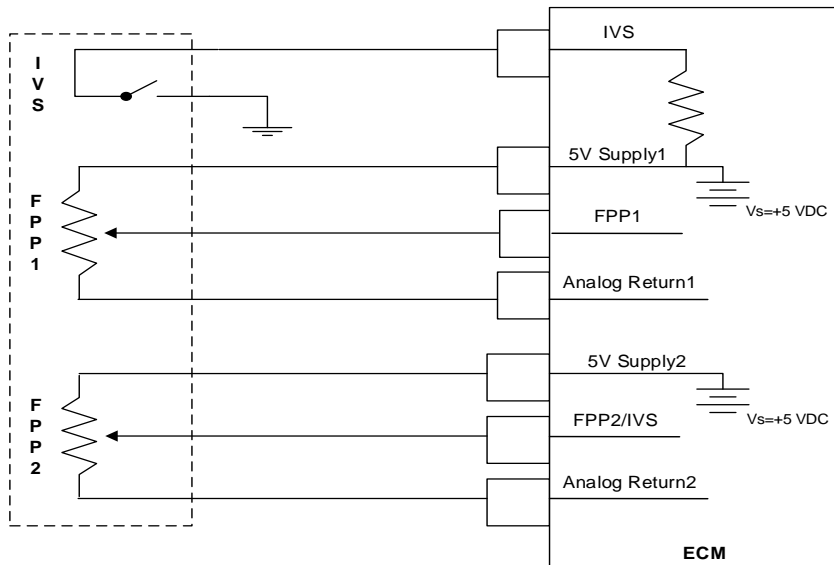

Hardware/Circuit:	Electronic foot pedal/throttle control sensor
--------------------------	---

Hardware/Circuit Description:	<p>The FPP sensor is an electronic device that is coupled to a mechanically driven input as commanded by the vehicle/engine operator. A FPP sensor may be, but is not limited to a foot pedal assembly, a cable-lever-sensor assembly, or a rotary potentiometer. General sensor configurations consist of single potentiometer with IVS, two potentiometers, or two potentiometers with IVS. The FPP sensor outputs are proportional to the commanded input. The ECM uses the FPP sensor inputs to control the throttle and adjust the engine's load in order to achieve the requested power. Since the FPP sensor inputs directly affect the engine's power output, redundant sensors are generally used to ensure safe, reliable operation.</p>
--------------------------------------	--

Possible Causes:	<p>This fault is only applicable with dual potentiometer/single IVS sensors and indicates that the two FPP percentages correlate and register an at idle condition but the IVS state reads off idle.</p>
-------------------------	--

DTC 2131: Troubleshooting Tree

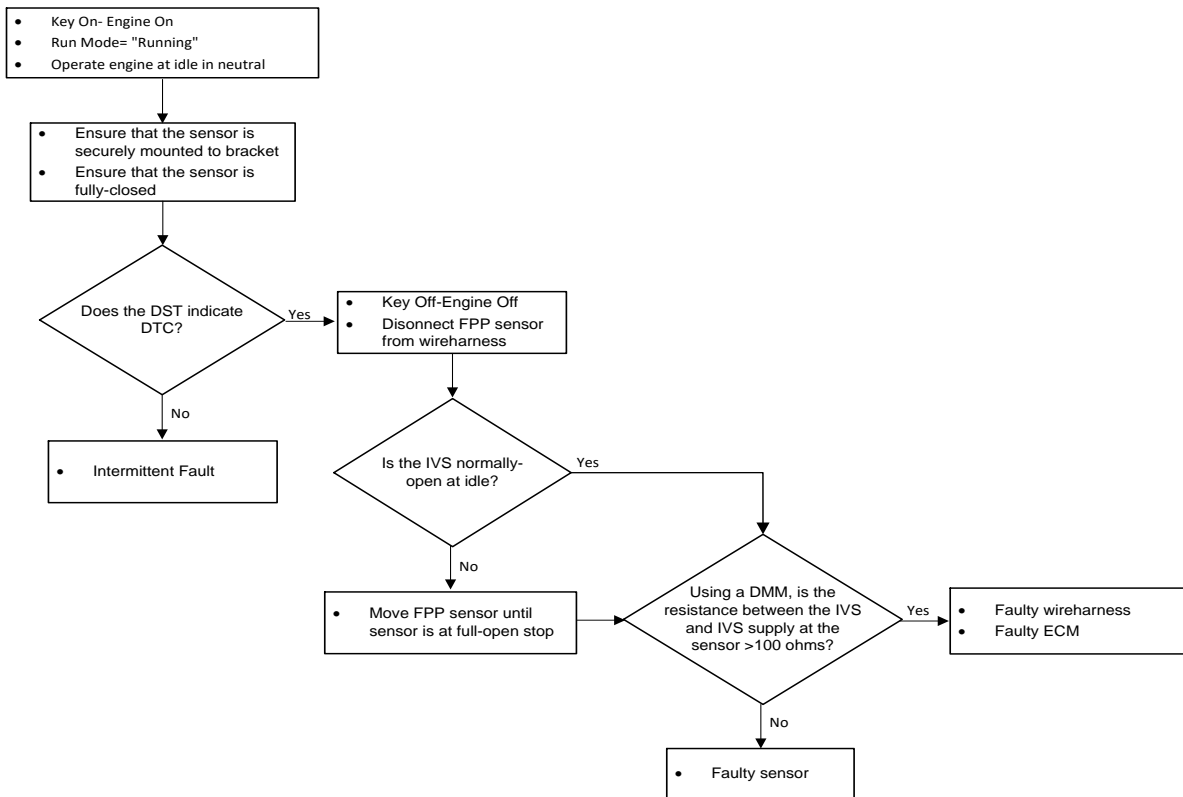

Code			Fault Description
DTC	SPN	FMI	
2135	51	31	TPS1-2 Simultaneous Voltages Out of Range

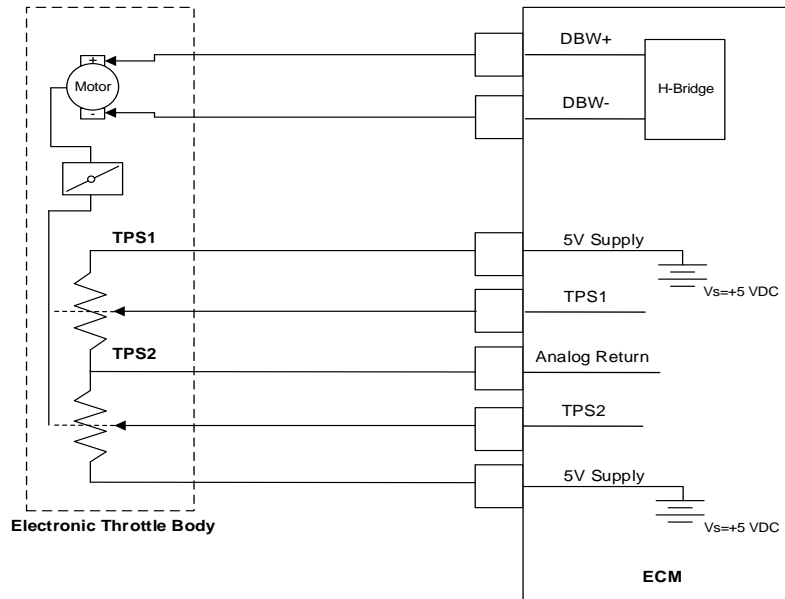

Hardware/Circuit:	Electronic throttle body
--------------------------	--------------------------

Hardware/Circuit Description:	The throttle is an air valve used to control the amount of air available to the engine for combustion and thereby the engine's power output. An electronic throttle simply means that a motor is controlled electronically through an electronic control system to actuate the throttle valve. Electronic throttle control is advantageous because it tends to offer improved starting, improved idle governing, improved maximum speed governing, excellent load acceptance and steady-state speed governing, permits engine synchronization, and offers flexibility to protect the engine during certain fault conditions.
--------------------------------------	--

Possible Causes:	This fault is generated when both feedback sensors in the ETB (TPS1 and TPS2) simultaneously produce out-of-range faults. This fault indicates that there is no feedback of the throttle valve and as a result throttle control cannot take place. This fault is, and should always be, configured to shut the engine down.
-------------------------	---

DTC 2135: Diagnostic Aid

- Troubleshoot according to TPS1 voltage out-of-range following DTC 122 and 123 procedures.
- Troubleshoot according to TPS2 voltage out-of-range following DTC 222 and 223 procedures.

Code			Fault Description
DTC	SPN	FMI	
2139	91	1	FPP1 Lower Than IVS Limit
2140	29	1	FPP2 Lower Than IVS Limit

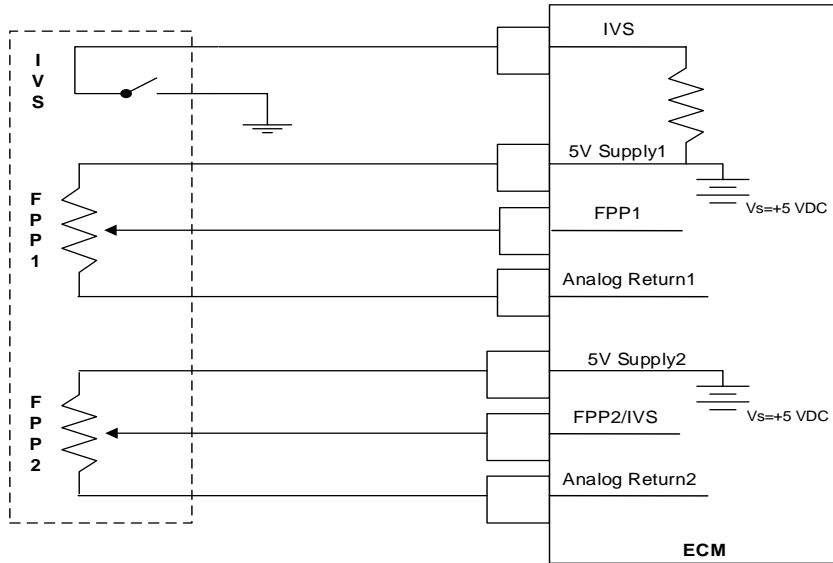

Hardware/Circuit:	Foot Pedal Position/Idle Validation Switch 1/2
--------------------------	--

Hardware/Circuit Description:	<p>The engine load command to the ECM is determined by operator depression of the electronic foot pedal. The ECM monitors the foot pedal position and controls the throttle to maintain the commanded power level. Because a problem with the foot pedal signal can result in a higher or lower power than intended by the operator, the pedal used with this control system incorporates a sensor with an idle validation switch. Checks and cross checks are constantly conducted by the ECM to determine the validity of the signals. The Idle Validation Switch (IVS) is a normally open contact (idle) that grounds (closed contacts) the IVS circuit to the ECM when the pedal is depressed more than the idle position.</p>
--------------------------------------	--

Possible Causes:	This fault will set if the IVS is at idle (open) and the FPP (FPP1 or FPP2) voltage is less than the fault limit defined in the calibration.
-------------------------	--

DTC 2139: Troubleshooting Tree

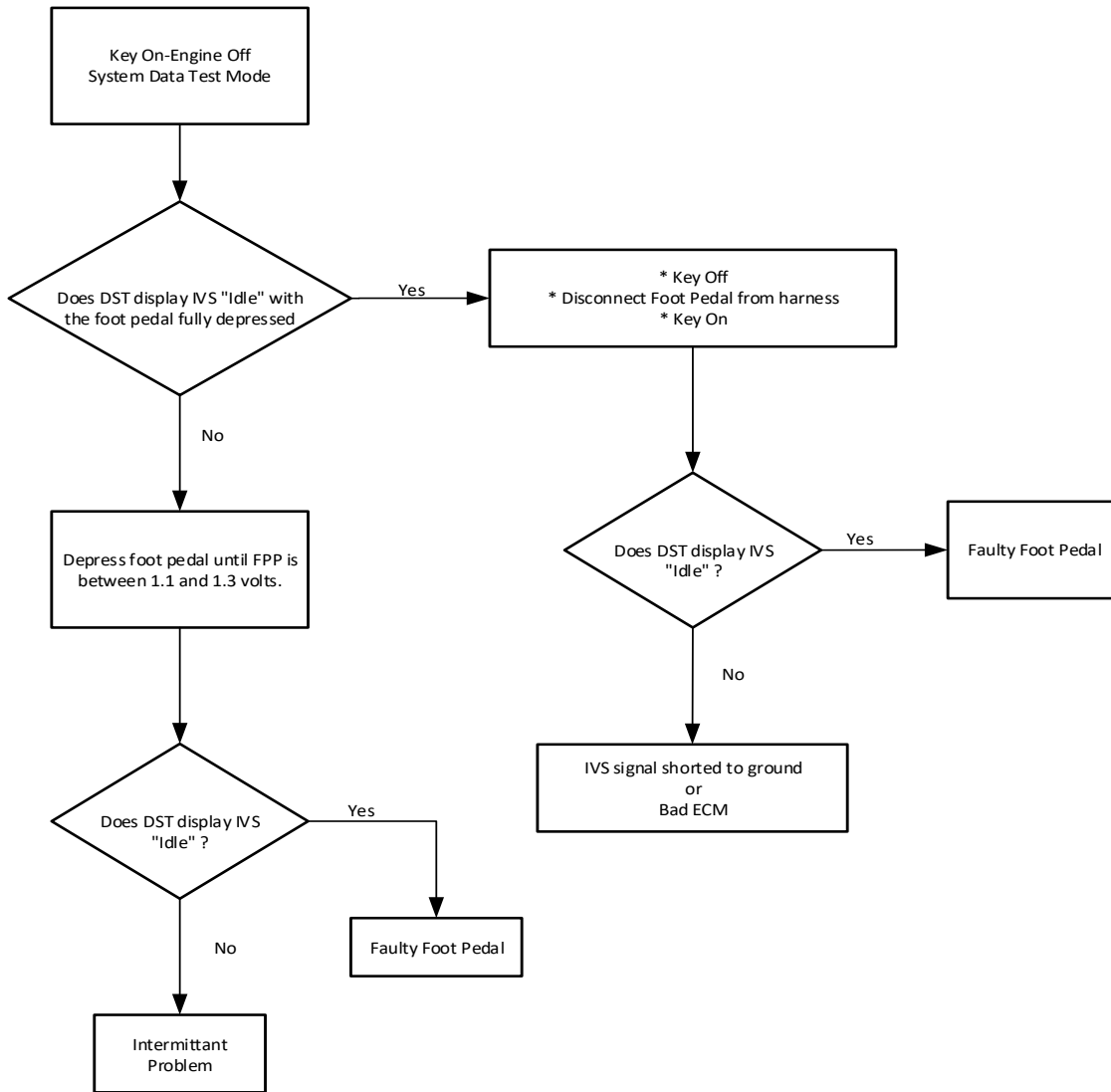

DTC 2140: Troubleshooting Tree

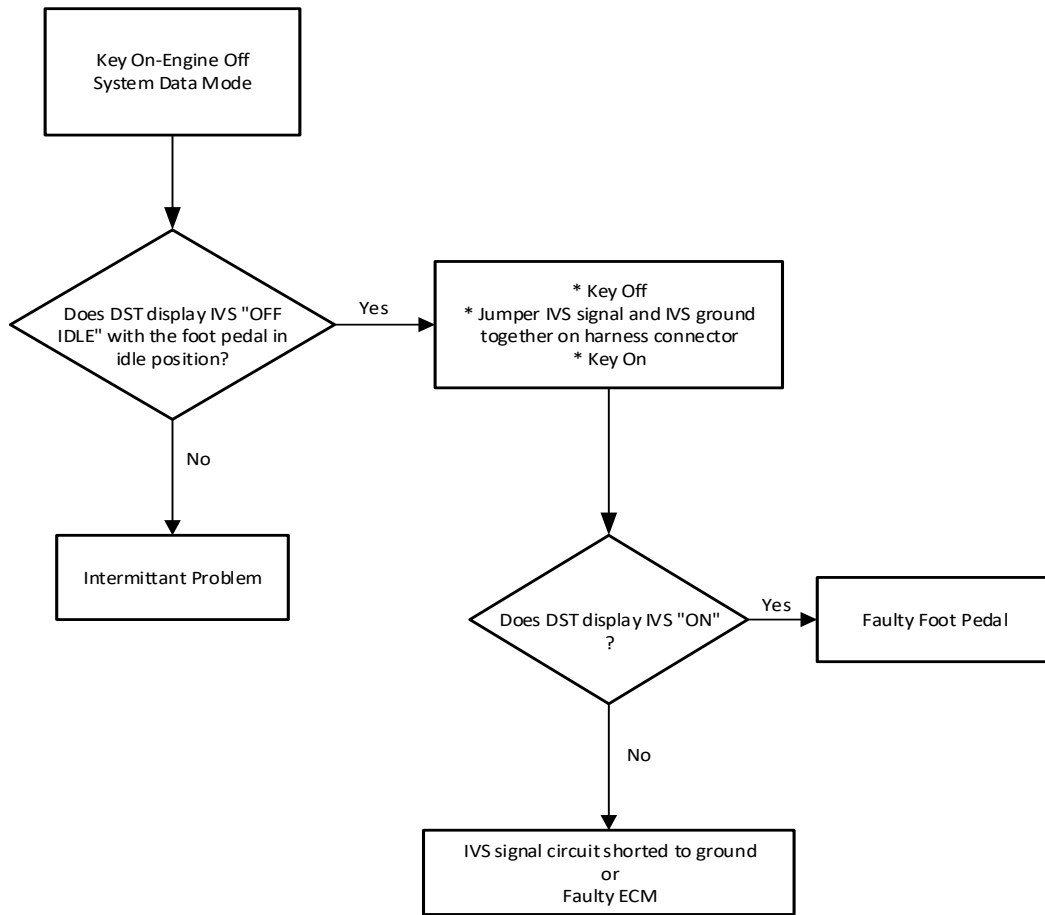

Code			Fault Description
DTC	SPN	FMI	
2229	108	0	BP High Pressure

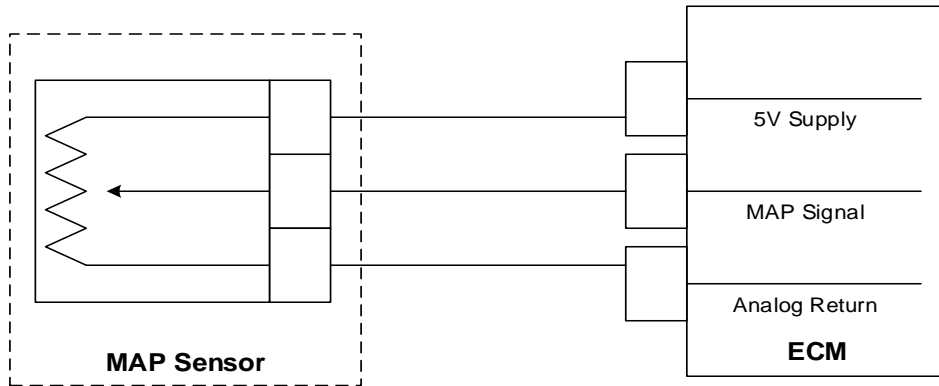

Hardware/Circuit:	Barometric Temperature / Manifold Absolute Pressure Sensor
--------------------------	--

Hardware/Circuit Description:	Barometric Pressure is estimated from the MAP sensor at key-on and in some calibrations during low speed/high load operation as defined in the engine's calibration. The barometric pressure value is used for fuel and airflow calculations and equivalence ratio targets based on altitude.
--------------------------------------	---

Possible Causes:	This fault sets if the barometric pressure is higher than the maximum pressure (psia) as defined in the diagnostic calibration.
-------------------------	---

Code			Fault Description
DTC	SPN	FMI	
2300	1268	5	PRIMARY LOOP OPEN OR LOW-SIDE SHORT TO GROUND Cylinder 1
2303	1269	5	PRIMARY LOOP OPEN OR LOW-SIDE SHORT TO GROUND Cylinder 2
2306	1270	5	PRIMARY LOOP OPEN OR LOW-SIDE SHORT TO GROUND Cylinder 3
2309	1271	5	PRIMARY LOOP OPEN OR LOW-SIDE SHORT TO GROUND Cylinder 4
2312	1272	5	PRIMARY LOOP OPEN OR LOW-SIDE SHORT TO GROUND Cylinder 5
2315	1273	5	PRIMARY LOOP OPEN OR LOW-SIDE SHORT TO GROUND Cylinder 6
2318	1274	5	PRIMARY LOOP OPEN OR LOW-SIDE SHORT TO GROUND Cylinder 7
2321	1275	5	PRIMARY LOOP OPEN OR LOW-SIDE SHORT TO GROUND Cylinder 8

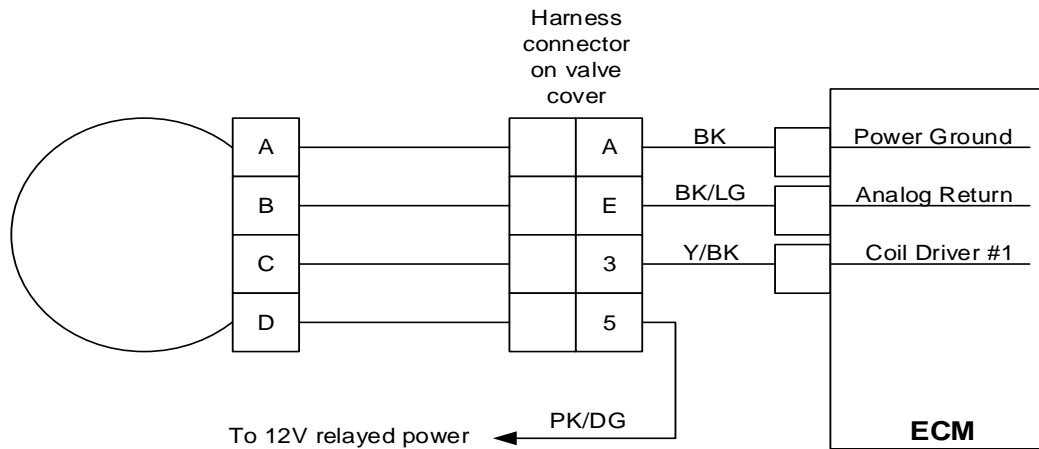

Hardware/Circuit:	Ignition/Spark Coil, cylinders 1-8 (Dumb-coil ONLY)
--------------------------	---

Hardware/Circuit Description:	Coil driver #1 fires either the 1st cylinder in the firing order or the 1st cylinder in the block order depending on the configuration of the 'Injector/Spark Diagnostic Numbering' scheme as set in calibration. Drivers 2-10 follow in-kind.
--------------------------------------	--

Possible Causes:	This fault will set if the ECM detects x number of coil firings in which the adaptive dwell adjustment is greater than y ms. or the total dwell is greater than w ms. and battery voltage is greater than z volts as defined in the diagnostic calibration.
-------------------------	---

DTC 2300-2303-2306-2309-2312-2315-2318-2321: Troubleshooting Tree

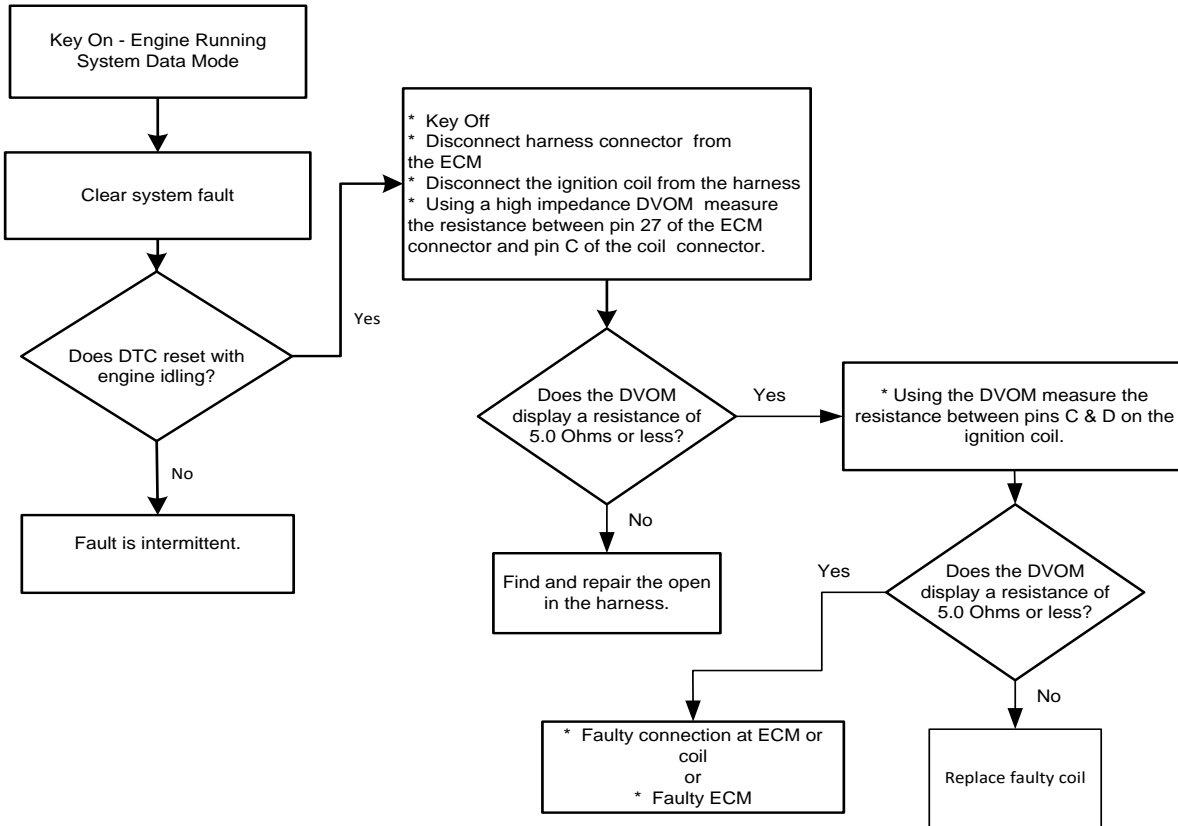

Code			Fault Description
DTC	SPN	FMI	
2301	1268	6	Primary Coil Shorted 1
2304	1269	6	Primary Coil Shorted 2
2307	1270	6	Primary Coil Shorted 3
2310	1271	6	Primary Coil Shorted 4
2313	1272	6	Primary Coil Shorted 5
2316	1273	6	Primary Coil Shorted 6
2319	1274	6	Primary Coil Shorted 7
2322	1275	6	Primary Coil Shorted 8

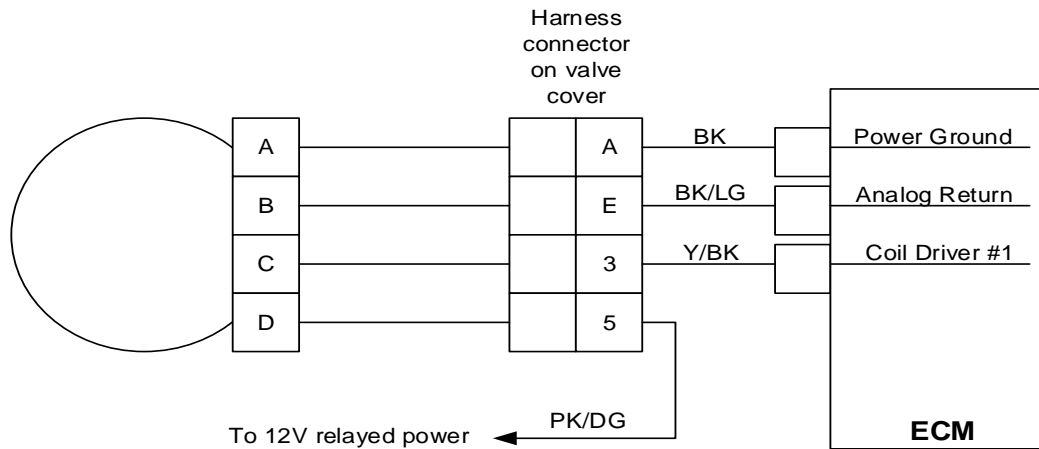

Hardware/Circuit:	Ignition/Spark Coil, cylinders 1-8 (Dumb-coil ONLY)
--------------------------	---

Hardware/Circuit Description:	Coil driver #1 fires either the 1st cylinder in the firing order or the 1st cylinder in the block order depending on the configuration of the 'Injector/Spark Diagnostic Numbering' scheme as set in calibration. Drivers 2-10 follow in-kind.
--------------------------------------	--

Possible Causes:	This fault will set if the ECM detects x number of coil firings in which the adaptive dwell adjustment is less than y ms. or the total dwell is less than w ms. and battery voltage is less than z volts as defined in the diagnostic calibration.
-------------------------	--

DTC 2301-2304-2307-2310-2313-2316-2319-2322: Troubleshooting Tree

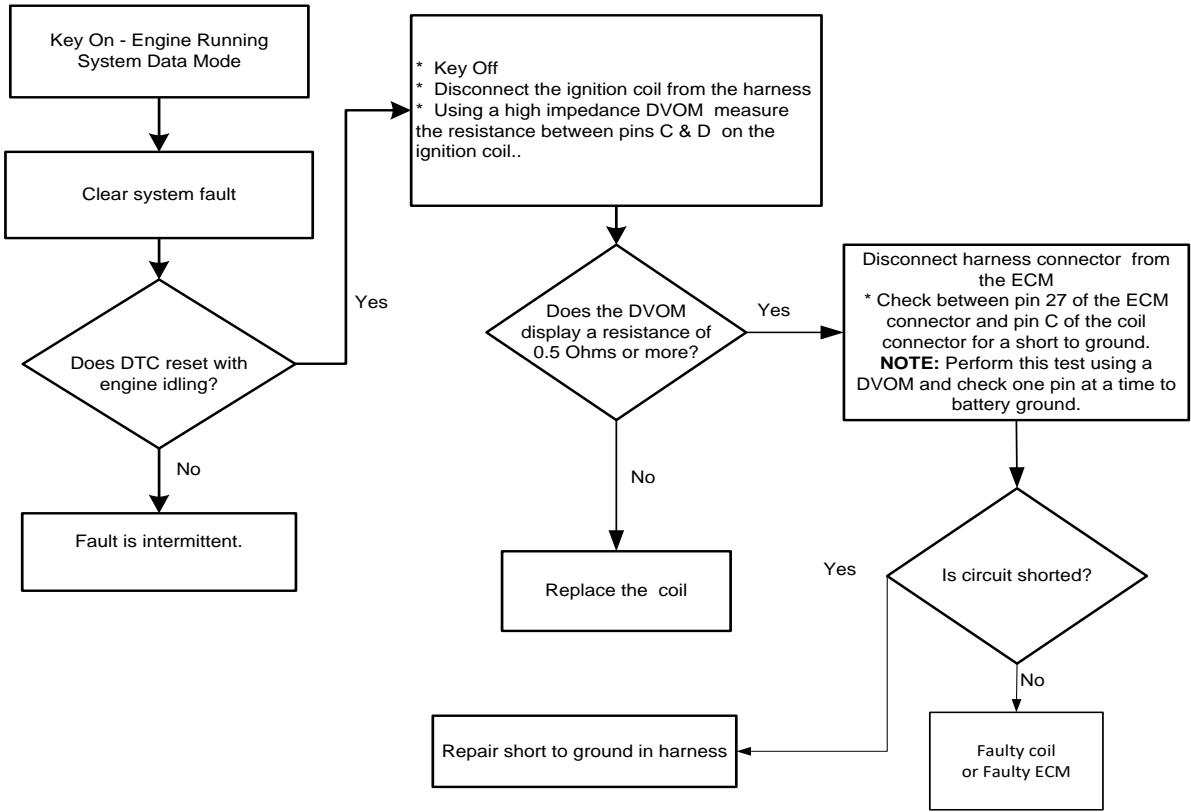

Code			Fault Description
DTC	SPN	FMI	
2618	645	4	Tach Output Ground Short

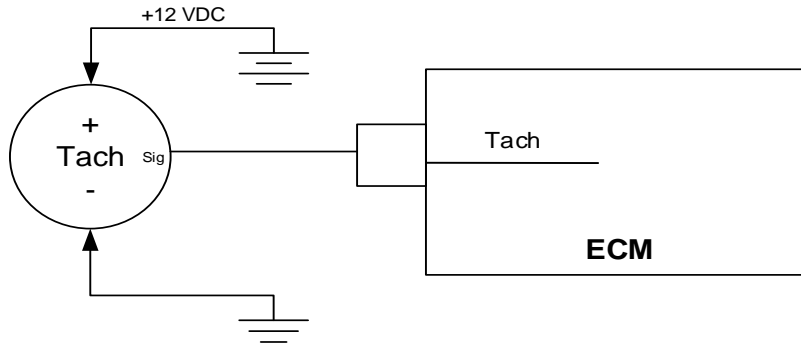

Hardware/Circuit:	Tachometer Gauge
--------------------------	------------------

Hardware/Circuit Description:	This output is a 0-12 VDC constant duty-cycle, variable frequency square-wave used to drive a digital tachometer.
--------------------------------------	---

Possible Causes:	This fault sets if the ECM tachometer output senses a short to ground.
-------------------------	--

DTC 2618: Troubleshooting Tree

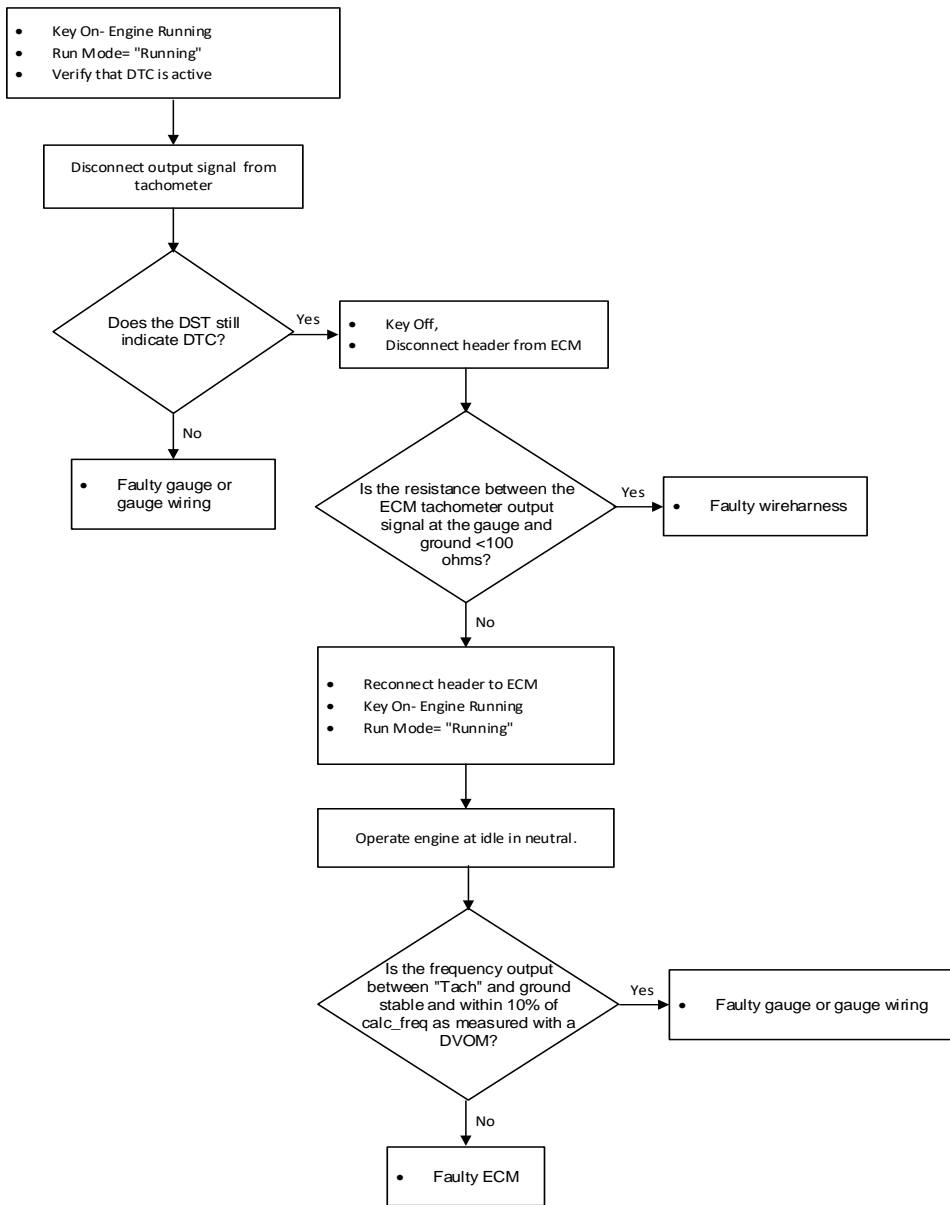

$$\text{calc_freq (hz.)} = \frac{\# \text{ of cyl}}{2} \times \frac{N}{60}, \text{ where } N = \text{engine speed in RPM}$$

Code			Fault Description
DTC	SPN	FMI	
2619	645	3	Tach Output Short to Power

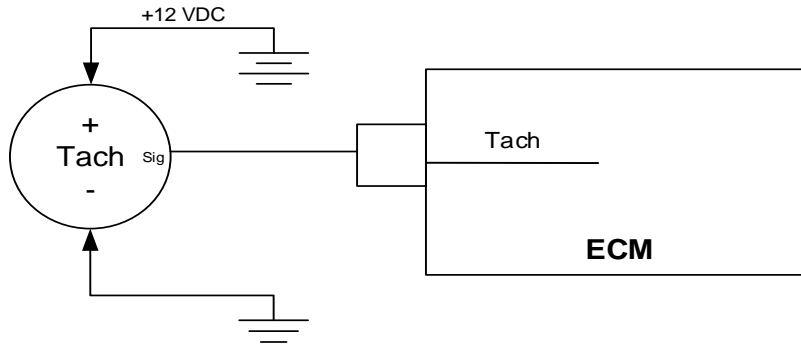

Hardware/Circuit:	Tachometer Gauge
--------------------------	------------------

Hardware/Circuit Description:	This output is a 0-12 VDC constant duty-cycle, variable frequency square-wave used to drive a digital tachometer.
--------------------------------------	---

Possible Causes:	This fault sets if the ECM tachometer output senses a short to power.
-------------------------	---

DTC 2619: Troubleshooting Tree

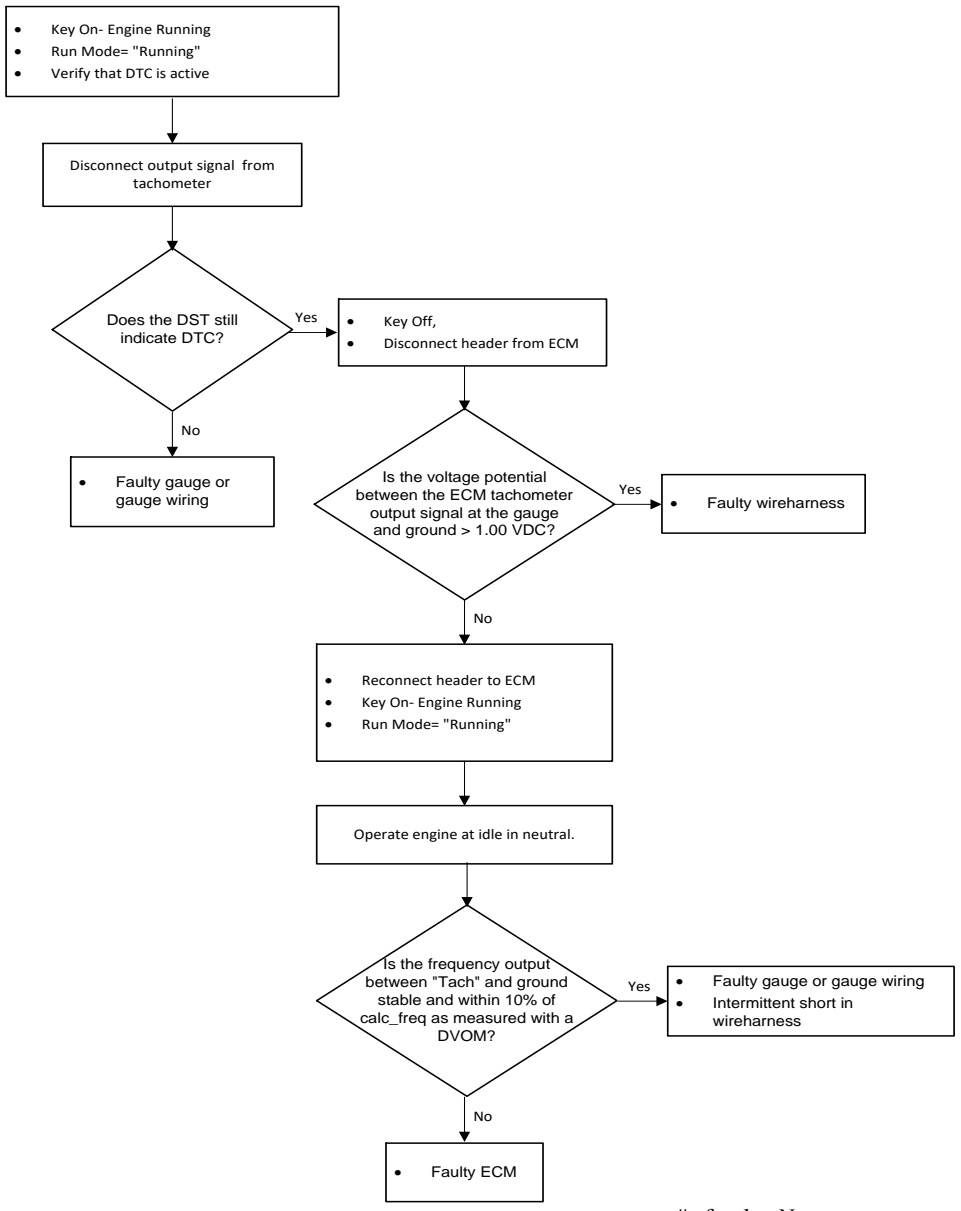

$$\text{calc_freq (hz.)} = \frac{\# \text{ of cyl}}{2} \times \frac{N}{60}, \text{ where } N = \text{engine speed in RPM}$$

Code			Fault Description
DTC	SPN	FMI	
31	3222	4	EGO 1 (pre-cat) Heater Circuit Open / Ground Short
51	3232	4	EGO2 (post-cat) Heater Circuit Open / Ground Short

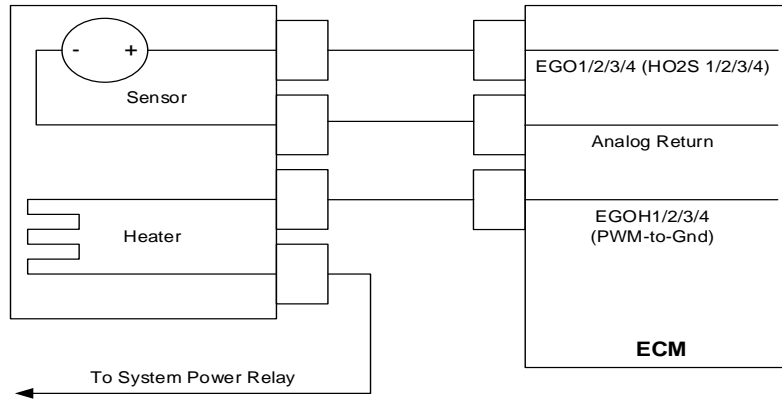

Hardware/Circuit:	Heated Exhaust Gas Oxygen Sensor (Bank and Position Assignment as Defined in Calibration)	
Hardware/Circuit Description:	<p>The HEGO/HO2S sensor is a switching-type sensor about stoichiometry that measures the oxygen content present in the exhaust to determine if the fuel flow to the engine is correct. An oxygen sensor must be hot to generate a voltage signal reading so a small heating element is in the O2 sensor to assist the sensor to achieve operating temperature more quickly.</p> <p>EGO 1 heater fault illuminate the MIL and turn off closed loop and adaptive learn.</p> <p>EGO 2 heater fault will only illuminate the MIL.</p>	
Possible Causes:	<p>This fault will set if ECU detects that the low side voltage of the O2 sensor heater circuit is < 5% of battery power and the PWM duty cycle is < 5% for more than 2 seconds. This could be a result of heater line open circuit, the control line to the ECU shorted to ground, the O2 sensor disconnected or a faulty sensor assembly.</p>	
Troubleshooting:	<p>Check the EGO connector for proper connection.</p> <p>Check voltage of the EGO heater control line.</p> <p>Check the power supply circuit for continuity and fuse integrity.</p> <p>Check for bare or pinched wires.</p>	Check

Code			Fault Description
DTC	SPN	FMI	
32	3222	3	EGO 1 (pre-cat) Heater Circuit Short to Power
52	3232	3	EGO2 (post-cat) Heater Circuit Short to Power

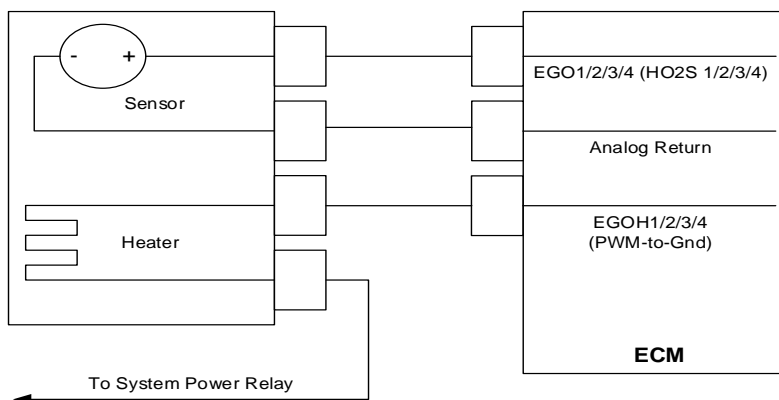

Hardware/Circuit:	Heated Exhaust Gas Oxygen Sensor (Bank and Position Assignment as Defined in Calibration)
--------------------------	--

Hardware/Circuit Description:	<p>The HEGO/HO2S sensor is a switching-type sensor about stoichiometry that measures the oxygen content present in the exhaust to determine if the fuel flow to the engine is correct. An oxygen sensor must be hot to generate a voltage signal reading so a small heating element is in the O2 sensor to assist the sensor to achieve operating temperature more quickly.</p> <p>EGO 1 heater fault illuminate the MIL and turn off closed loop and adaptive learn.</p> <p>EGO 2 heater fault will only illuminate the MIL.</p>
--------------------------------------	---

Possible Causes:	<p>This fault will set if ECU detects that the low side voltage of the O2 sensor heater circuit is >90% of battery power and the PWM duty cycle is >90% for more than 2 seconds. This could be the heater control signal line shorted to the EGO heater power supply line, heater control signal line shorted to battery or a faulty EGO sensor assembly.</p>
-------------------------	---

Troubleshooting:	<p>Check the EGO connector for proper connection.</p> <p>Check voltage of the EGO heater control line.</p> <p>Check for bare or pinched wires.</p>
-------------------------	--

Code			Fault Description
DTC	SPN	FMI	
87	94	1	Fuel Pressure Low

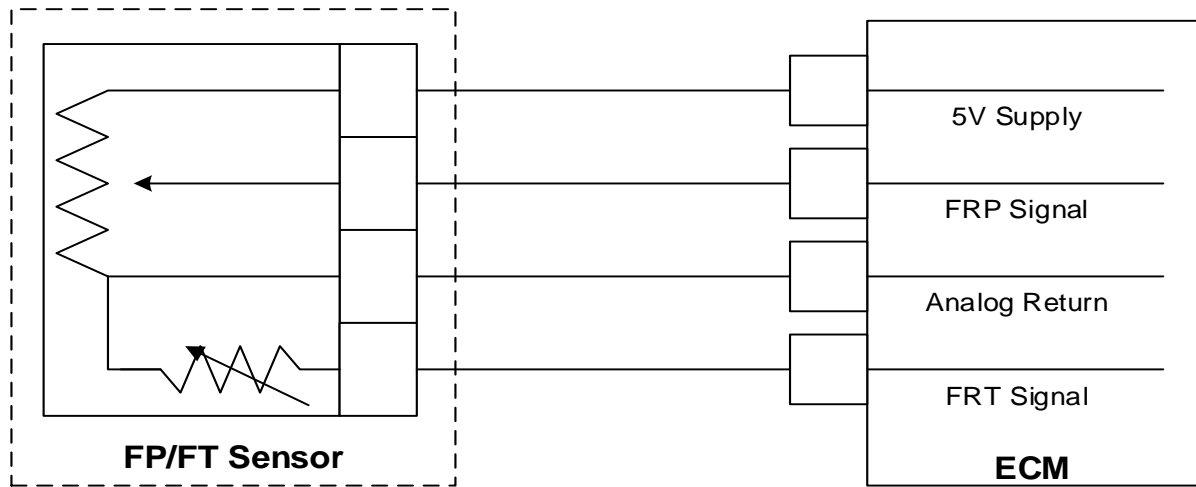

Hardware/Circuit:	Liquid Fuel Pressure and Temperature Sensor
--------------------------	---

Hardware/Circuit Description:	The fuel pressure sensor is installed inline in the gasoline fuel supply line and is used to provide fuel pressure feedback to the ECM. The ECM sets a target rail pressure based on running conditions and then the fuel pump is PWM controlled through a low side driver in the ECM. The fuel pressure sensor feedback is used to determine when the actual rail pressure has reached the target rail pressure.
--------------------------------------	---

Possible Causes:	This fault sets when measured fuel pressure is below a calibrated pressure value after a calibrated wait time. Typically 20 psia below engine model specific operating pressure after 2 seconds. Possible causes include faulty fuel pump, fuel pressure sensor failure, fuel pressure sensor circuit shorted to ground, faulty ECM.
-------------------------	--

DTC 87: Troubleshooting Tree

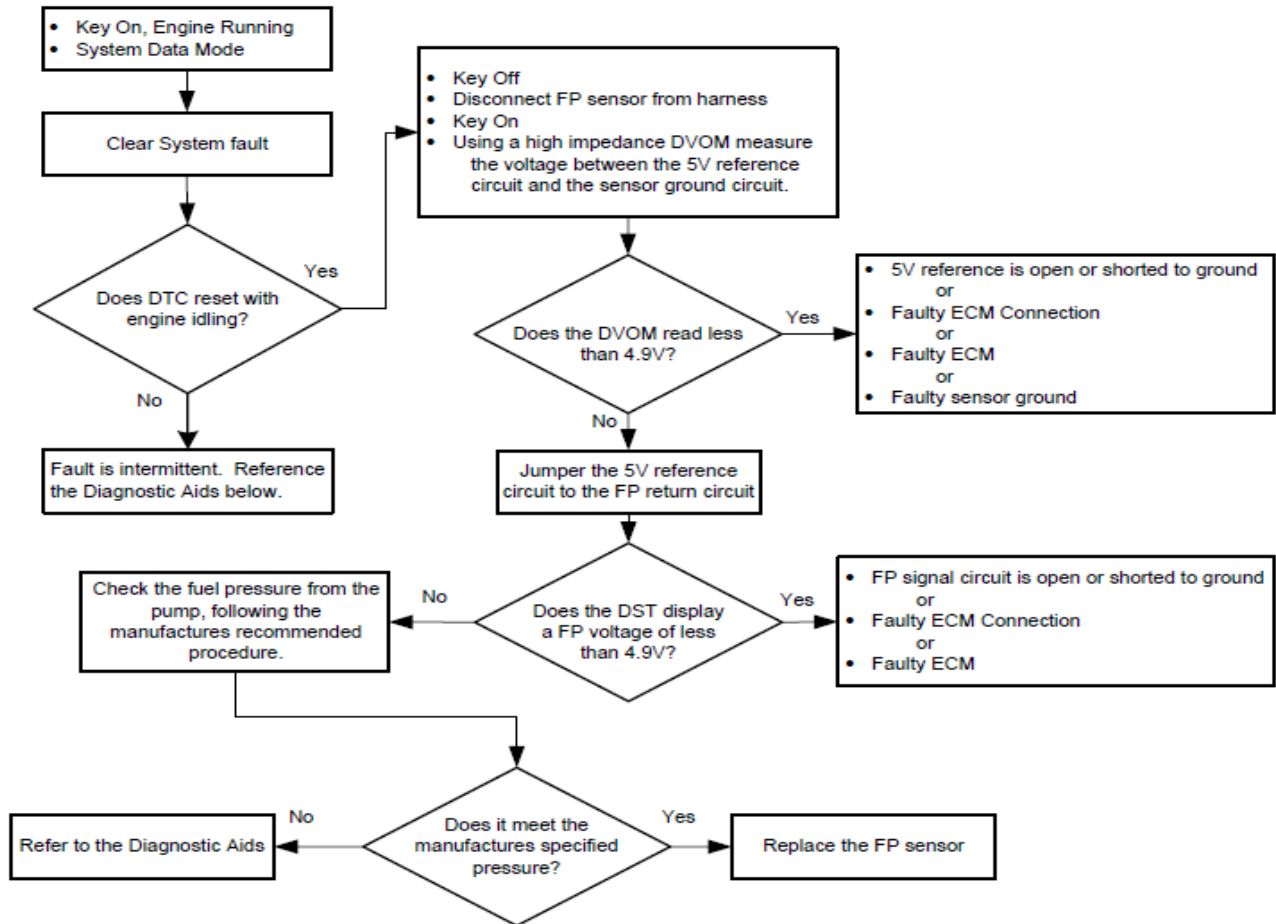

Diagnostic Aids

Fuel Filter – If a fuel filter is dirty, the fuel flow to the fuel pump may be restricted. Check filter and replace if necessary.

Fuel Line Restrictions – Check fuel line for kinks or pinched areas. Correct any fuel line or fitting restrictions.

Vapor Lock – Fuel system or pump temperature above the vapor pressure of the fuel.

Refer to Intermittent Diagnostics for additional aids.

Code			Fault Description
DTC	SPN	FMI	
88	94	0	Fuel Pressure High

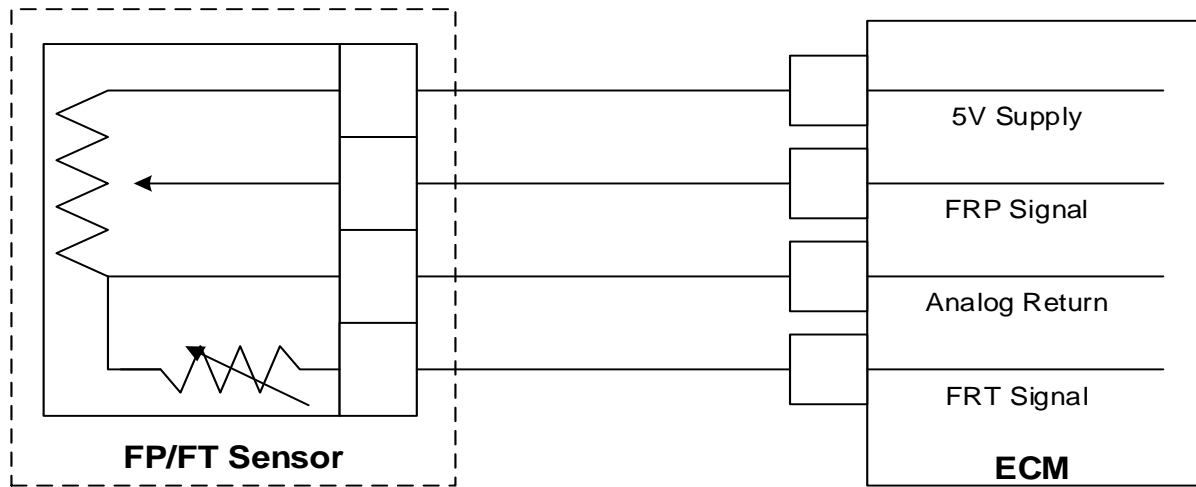

Hardware/Circuit:	Liquid Fuel Pressure and Temperature Sensor
--------------------------	---

Hardware/Circuit Description:	The fuel pressure sensor is installed inline in the gasoline fuel supply line and is used to provide fuel pressure feedback to the ECM. The ECM sets a target rail pressure based on running conditions and then the fuel pump is PWM controlled through a low side driver in the ECM. The fuel pressure sensor feedback is used to determine when the actual rail pressure has reached the target rail pressure.
--------------------------------------	---

Possible Causes:	This fault sets when measured fuel pressure exceeds a calibrated pressure value after a calibrated wait time. Typically 20 psia above engine model specific operating pressure after 2 seconds. Possible causes include faulty fuel pump, fuel pressure sensor failure, fuel pressure sensor circuit shorted to ground, faulty ECM.
-------------------------	---

DTC 88: Troubleshooting Tree

