



OPERATOR HANDBOOK

RSG

862

**Gasoline
LIQUEFIED PETROLEUM GAS (LPG)
NATURAL GAS (NG) ENGINES**



**Powertrain Assemblies & Components
Provided By Ford Component Sales**

**EDI 1070150
April 2025**



WARNING:



WARNING: ENGINE EXHAUST, SOME OF ITS CONSTITUENTS, AND CERTAIN VEHICLE COMPONENTS CONTAIN OR EMIT CHEMICALS KNOWN TO THE STATE OF CALIFORNIA TO CAUSE CANCER AND BIRTH DEFECTS OR OTHER REPRODUCTIVE HARM. IN ADDITION, CERTAIN FLUIDS CONTAINED IN VEHICLES AND CERTAIN PRODUCTS OF COMPONENT WEAR CONTAIN OR EMIT CHEMICALS KNOWN TO THE STATE OF CALIFORNIA TO CAUSE CANCER AND BIRTH DEFECTS OR OTHER REPRODUCTIVE HARM.

FORD RSG-862 ENGINES

Gasoline
LIQUEFIED PETROLEUM GAS (LPG)
NATURAL GAS (NG)

Reproduction in any manner, in whole or in part, is prohibited without the express permission in writing from

Engine Distributors Incorporated

Engine Distributors policy is one of continuous improvement and while every effort is made to ensure that this publication is up to date and correct in all respects, the right to change prices, specifications and equipment at any time without notice is reserved. Accordingly this publication is not to be regarded as a final description of any individual engine.

CONTENTS

HEALTH & SAFETY	6
General Guidelines:	6
Important Safety Notice.....	6
Notes, Cautions, and Warnings	7
FORWARD	8
ENGINE IDENTIFICATION.....	8
U.S.A. Engine Identification Decal	9
Federal Emissions Warranty Statement.....	10
California Emission Control Warranty Statement.....	10
What Is Covered?	11
PARTS AND SERVICE.....	12
SERVICE LITERATURE.....	12
BEFORE OPERATING THE ENGINE.....	12
OPERATING CONTROLS.....	12
Ignition or Isolation Switch	12
Safety Switch (where fitted)	13
Power Take-off (where fitted).....	13
Throttle Control (where fitted)	13
INSTRUMENTS.....	14
Ammeter (Where Fitted).....	14
Battery Condition Indicator (Where Fitted).....	14
Tachometer (Where Fitted)	14
Hourmeter (Where Fitted)	14
Oil Pressure Gauge (Where Fitted).....	14
Temperature Gauge (Where Fitted).....	15
Malfunction Indicator Light (Where Fitted)	15
Charge Indicator Light (Where Fitted).....	15
Safety Switch Override Button (Where Fitted)	15
Ignition or Isolation Switch	15
Fuel Select Switch (Where Fitted).....	15
STARTING THE ENGINE.....	16
Initial Start-up	16
To Start From cold	16
To Re-start When Warm	16

CONTENTS

STOPPING THE ENGINE	17
Normal Conditions.....	17
Abnormal Conditions.....	17
RUNNING-IN PROCEDURE	17
FUEL RECOMMENDATION.....	18
LUBRICATION AND MAINTENANCE.....	18
RECOMMENDED MAINTENANCE SCHEDULES.....	19
RECOMMENDED MAINTENANCE OPERATIONS	20
Recommended Lubricants	20
Used Engine Oils	21
Change Engine Oil	21
Check Engine Oil Level.....	22
Renew Engine Oil Filter	22
Ignition System.....	23
Renew Spark Plugs.....	23
Electronic Actuator	25
Check Condition of Ancillary Drive Belts.....	25
Check Engine Coolant Level.....	25
Renew Air Cleaner Element.....	26
Renew PCV Valve.....	26
GENERAL MAINTENANCE INFORMATION	27
Cooling System.....	27
Draining, Flushing and Filling the Cooling System.....	29
Engine Lubrication System	30
Electrical System.....	31
Generator	31
Storage.....	32
ENGINE SYSTEM CHECK.....	33
SPECIFICATIONS	38
TIGHTENING TORQUES.....	40
CONVERSION TABLE	41
FORD POWER PRODUCTS SERVICE	42

HEALTH & SAFETY



WARNING: THE FOLLOWING HEALTH AND SAFETY RECOMMENDATIONS SHOULD BE CAREFULLY OBSERVED.

Carrying out certain operations and handling some substances can be dangerous or harmful to the operator if the correct safety precautions are not observed. Some such precautions are recommended at the appropriate points in this book.

While it is important that these recommended safety precautions are observed, care near machinery is always necessary, and no list can be exhaustive. **ALWAYS BE ON YOUR GUARD!**

General Guidelines:

The following recommendations are for general guidance:

1. Always wear correctly fitting protective clothing which should be laundered regularly. Loose or baggy clothing can be extremely dangerous when working on running engines or machinery. Clothing which becomes impregnated with oil or other substances can constitute a health hazard due to prolonged contact with the skin even through underclothing.
2. So far as practicable, work on or close to engines or machinery only when they are stopped. If this is not practicable, remember to keep tools, test equipment and all parts of the body well away from the moving parts of the engine or equipment—fans, drive belts and pulleys are particularly dangerous. The electric cooling fan used on some installations is actuated automatically when the coolant reaches a specified temperature. For this reason, care should be taken to ensure that the ignition/isolating switch is OFF when working in the vicinity of the fan as an increase in coolant temperature may cause the fan suddenly to operate.
3. Avoid contact with exhaust pipes, exhaust manifolds and silencers when an engine is, or has recently been running; these can be very hot and can cause severe burns.
4. Many liquids used in engines or vehicles are harmful if taken internally or splashed into the eyes. In the event of accidentally swallowing gasoline (petrol), oil, diesel fuel, antifreeze, battery acid etc., **DO NOT ENCOURAGE VOMITING AND OBTAIN QUALIFIED MEDICAL ASSISTANCE IMMEDIATELY.**

Wear protective goggles when handling liquids which are harmful to the eyes these include ammonia and battery acid. If any of these substances are splashed in the eyes, wash out thoroughly with clean water and **OBTAIN QUALIFIED MEDICAL ASSISTANCE IMMEDIATELY.**

Important Safety Notice

Appropriate service methods and proper repair procedures are essential for the safe, reliable operation of all industrial engines as well as the personal safety of the individual doing the work. This operator handbook provides general directions for accomplishing service and repair work with tested, effective techniques. Following them will help assure reliability.

There are numerous variations in procedures, techniques, tools and parts for servicing equipment, as well as in the skill of the individual doing the work. This manual cannot possibly anticipate all such variations and provide advice or cautions as to each. Accordingly, anyone who departs from the instructions

provided in this Manual must first establish that neither personal safety nor equipment integrity are compromised by the choice of methods, tools or parts.

Notes, Cautions, and Warnings

As you read through the procedures, you will come across NOTES, CAUTIONS, and WARNINGS. Each one is there for a specific purpose. NOTES gives you added information that will help you to complete a particular procedure. CAUTIONS are given to prevent you from making an error that could damage the equipment. WARNINGS remind you to be especially careful in those areas where carelessness can cause personal injury. The following list contains some general WARNINGS that you should follow when you work on the equipment.

GENERAL WARNINGS:

- Always wear safety glasses for eye protection.
- Use safety stands whenever a procedure requires you to be under the equipment.
- Be sure that the ignition switch is always in the OFF position, unless otherwise required by the procedure.
- Set the parking brake (if equipped) when working on the equipment. If you have an automatic transmission, set it in PARK REVERSE (engine off) or NEUTRAL (engine on) unless instructed otherwise for a specific operation. Place wood blocks (4"x 4" or larger) to the front and rear surfaces of the tires to provide further restraint from inadvertent equipment movement.
- Operate the engine only in a well ventilated area to avoid the danger of carbon monoxide.
- Keep yourself and your clothing away from moving parts when the engine is running, especially the fan belts.
- To prevent serious burns, avoid contact with hot metal parts such as the radiator, exhaust manifold, tail pipe, catalytic converter and muffler.
- Do not smoke while working on the equipment.
- To reduce the risk of injury, always remove rings, watches, loose hanging jewelry, and loose clothing before beginning to work on the equipment. Tie long hair securely behind the head.
- Keep hands and other objects clear of the radiator fan blades. Electric cooling fans can start to operate at any time by an increase in underhood temperatures, even though the ignition is in the OFF position. Therefore, care should be taken to ensure that the electric cooling fan is completely disconnected when working under the hood.

FORWARD

This book contains operating and maintenance instructions for the engine(s) listed on the title page.

The life of your engine unit and the delivery of the high performance built into it will depend on the care it receives throughout its life. It is the operator's responsibility to ensure that the engine is correctly operated and that the maintenance operations outlined in this book are carried out regularly after the specified hours of operation have been reached. We consider it to be in your interests to enlist the aid of an authorized Ford Power Products Distributor not only when repairs are required but also for regular maintenance. Distributors are listed at the back of this handbook.

Regular maintenance will result in minimal operating costs.

Engines manufactured by Ford Motor Company are available through Ford Power Products Distributors. When in need of parts or service, contact your local Authorized Distributor. In overseas territories, in the event of difficulties, communicate directly with the supervising Ford affiliated Company in your area whose address appears at the end of this book.

Where the terms "Right" or "Left" occur in this publication, they refer to the respective sides of the engine when viewed from the rear or flywheel end.

Pistons and valves are numbered from the front or timing cover end of the engine commencing at No. 1.

You may find that your engine assembly includes optional equipment not specifically covered in the following text. Nevertheless, the maintenance procedures outlined in this book still apply to your engine

ENGINE IDENTIFICATION

Because Engine Distributors has such a wide range of industrial gasoline and diesel engines - manufactured both in the U.S. and overseas - it is important that you have as complete identification of the engine as possible in order to provide the correct replacement parts. Review the list of distributors for a distributor in your area. You can obtain a standard parts listing describing the parts. It remains a distributor function to identify the part number.

The key to identifying the engine is the identification decal mounted on the engine rocker cover. That decal provides not only the engine serial number, but also the exact model or type, configuration code and customer name. The combination of that data permits you to isolate the precise engine, build level and customer so you can determine the correct replacement parts.

EDI Engine Identification Decal

An identification Decal is affixed to the valve cover of the engine. The decal contains the engine serial number which identifies this unit from all others. Use all numbers when seeking information or ordering replacement parts for this engine.

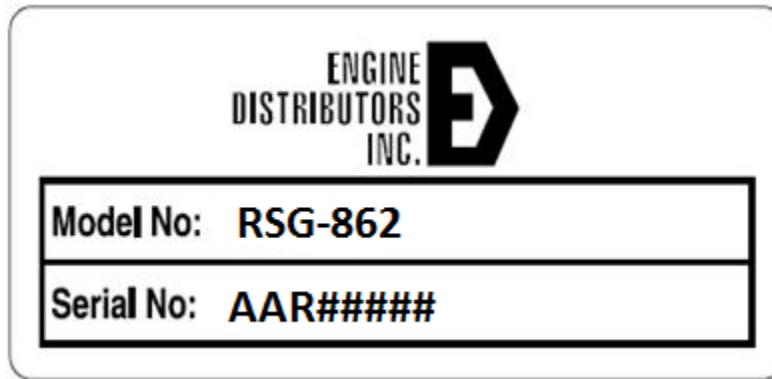

For handy reference, transfer the data recorded on this decal to a safe place.

EDI Engine Serial Number Identification Key

Code	Year/ Month	Year	Month	Model	Production #
C		2006	January	T = TSG415 1.5L	5 DIGIT: Starts 00100
D		2007	February	T = TSG416 1.6L	
E		2008	March	D = DSG423 2.3L	
F		2009	April	M = MSG425 2.5L	
G		2010	May	C = CSG637 3.7L	
H		2011	June	R = RSG862 6.2L	
I		2012	July	W = WSG1068 6.8L	
J		2013	August		
K		2014	September		
L		2015	October		
M		2016	November		
N		2017	December		
O		2018			
P		2019			
Q		2020			

Example: HED00100

Position	Description
1	Model Year: H = 2011
2	Month: E = March
3	Engine Family: D = DSG423 2.3L
4,5,6,7,8	Rolling Sequential Numbers

Your Warranty Rights and Obligations

The U.S. EPA and Engine Distributors, Inc. are pleased to explain the emission control system warranty on your new 2017 model year emission certified engine (or brand equipment). New off-road large spark-ignition (LSI) engines must be designed, built and equipped to meet stringent Federal and State anti-smog standards. Engine Distributors, Inc. warrants that the emission control system on your engine for the periods of time listed below provided there has been no abuse, neglect or improper maintenance of your engine.

Your emission control system may include parts such as the carburetor, regulator or fuel-injection system, ignition system, engine computer unit (ECM), catalytic converter and air induction system. Also included may be sensors, hoses, belts, connectors and other emission-related assemblies.

Where a warrantable condition exists, Engine Distributors, Inc will repair your LSI engine at no cost to you including diagnosis, parts, and labor.

Manufacturer's Warranty Coverage

The new 2014 model year off-road large spark-ignition engines are warranted for three years or 2500 hours of service, whichever occurs first from the date the equipment is delivered to the first retail purchaser or when the equipment is first placed in service. If any emission-related part on the engine is defective, the part will be repaired or replaced by an authorized Engine Distributors, Inc. dealer. This is your *General Emissions Warranty*.

For five years or 3500 hours of service (whichever occurs first) if any emission-related part specially noted with coverage for five years or 3500 hours is defective, the part will be repaired or replaced by and authorized Engine Distributors, Inc. dealer. This is your *High Priced Parts Emission Warranty*.

Owner's Warranty Responsibilities

As the off-road LSI engine owner, you are responsible for the performance of the required maintenance listed in your owner's manual. Engine Distributors, Inc. recommends that you retain all records covering maintenance on your off-road engine, but Engine Distributors, Inc. cannot deny warranty solely for the lack of receipts or for your failure to ensure the performance of all scheduled maintenance.

As the off-road large spark-ignition engine owner, you should however be aware that Engine Distributors, Inc. may deny you warranty coverage if your off-road large spark-ignition engine or a part has failed due to abuse, neglect, improper maintenance or unapproved modifications.

Depending on the model of engine you have purchased, your engine may be designed to operate on LPG, Gasoline, and/or Natural Gas fuels. Use of any other fuel may result in your engine no longer operating in compliance with applicable emissions requirements.

You are responsible for initiating the warranty process. Engine Distributors suggests that you present your off-road large spark-ignition engine to an Engine Distributors, Inc. dealer as soon as a problem exists. The warranty repairs should be completed by the dealer as expeditiously as possible.

If you have any questions regarding your warranty rights and responsibilities, you should contact Engine Distributors, Inc. at (800) 220-2700.

What is Covered

Below is a list of the systems that affect emissions on your engine. Emission control components on these systems are covered by the emissions warranties as applicable.

If failure of one of the components listed below results in failure of another part, both will be covered by this warranty. For detailed information concerning specific components covered by these emission control systems warranties, ask your dealer.

General Emissions Warranty Parts List – 3 years or 2,500 hours, whichever comes first

- Fuel injection system.
 - Air/fuel ratio feedback and control system.
 - Carburetor system (internal parts and/or pressure regulator or fuel mixer or injection system).
- Air Induction System
 - Air intake system.
- Catalyst or Thermal Reactor System
- Positive Crankcase Ventilation (PCV) System.
 - PCV Valve.
 - Oil Filler Cap.
- Ignition Control System
 - Ignition module(s).
 - Spark Plugs
- Miscellaneous items Used in Above Systems
 - Vacuum, temperature, and time sensitive valves and switches.
 - Sensors used for electronic controls.
 - Hoses, belts, connectors, assemblies, clamps, fittings, tubing, sealing gaskets or devices, and mounting hardware.
 - Pulleys, belts and idlers.
 - Vaporizer (For LPG model of BEDIB06.8WSG only)

High Priced Emissions Warranty Parts List – 5 years or 3,500 hours, whichever comes first:

- Electronic Throttle: (2.5MSG, 6.8WSG, 6.8EN0, 6.8EP0)
- Throttle Body (1.6L only)
- ECM: (All Families)
- Pressure Regulator: (1.6L and 6.8L)
- CARB/MIX: (2.5MSG, 6.8EP0, 6.8EN0)
- Intake Manifold: (2.5L and 6.8L Only)
- Exhaust Manifold: (All Families)
- Catalyst: (1.6TS2, 2.5MSG, 6.8WSG)

SERVICE LITERATURE

A service manual can be purchased from your EDI distributor. This publication will provide the necessary servicing and overhaul information for your Ford Power Products engine.

- RSG862 SERVICE MANUAL – 1070200 EDI
- RSG862 PARTS LIST – 1070190 EDI

BEFORE OPERATING THE ENGINE

1. Before operating a new engine it should be thoroughly inspected to ensure that during transit and installation it has not suffered damage likely to affect its subsequent operation. Controls and instruments should be studied carefully in order that their functions are thoroughly understood.
2. Check that the radiator (where applicable) is full and top off as necessary -- Refer to "Cooling System" on page 28 for recommended coolant mixtures.
3. In the case of marine/industrial engines, ensure that there is coolant in the degas/expansion tank (where applicable).

CAUTION: Under no circumstances may the engine be started without liquid in the cooling system.

4. Check the engine oil level and top up or fill as necessary -- Refer to "Check Engine Oil Level" on page 23. For the correct type and grade of oil -- Refer to "Recommended Lubricants" on page 21.
5. Ensure that the battery is fully charged and, if necessary, top up with distilled water.

NOTE: Ensure that ALL wiring ground connections are properly made to a clean point on the chassis/frame.

6. The engine must be started in accordance with the starting instructions -- Refer to "STARTING THE ENGINE" on page 17.

OPERATING CONTROLS

Ignition or Isolation Switch

An ignition or isolation switch is usually fitted which connects the engine starter motor and other electrical equipment to the battery. The switch can be moved to any of the four positions shown by rotating the key. These positions are:

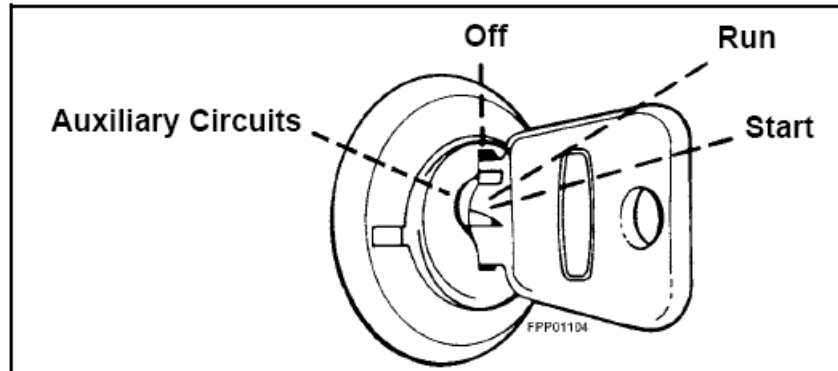

1. Auxiliary Circuits - When moved to this position the auxiliary electrical equipment such as radios and heater fans, can be operated without also connecting the starting circuit with the battery.
2. Off - When set to this position, the switch disconnects the auxiliary electrical equipment and the starting circuit from the battery. The key can be removed from the switch when it is in this position; this will help to prevent unauthorized operation of the engine.
3. Run - This switch position connects the auxiliary circuits as described previously, and the alternator is given initial excitation via the battery.
4. Start - In this position, the starter solenoid is energized and the starter motor cranks the engine. The switch, when released, automatically returns to the RUN position.

Safety Switch (where fitted)

A low oil pressure/high water temperature safety switch may be fitted. This automatically shuts off the ignition when the oil pressure drops below a pre-set value, or when the water temperature rises above a pre-set value. A button on the instrument panel is used to override the safety switch when starting the engine. The safety switch override button must be depressed to start the engine.

NOTE: With EDI GCP safety shut-down incorporated oil pressure below 6 psi and/ or coolant temperature goes above 250° F, will shut-down ignition system. Corrective action must be taken and key recycled to restart.

Power Take-off (where fitted)

The power take-off control handle allows engagement and disengagement of the power take-off clutch. Moving the lever towards the engine engages the clutch and moving the lever away from the engine disengages the clutch.

When moving the handle to engage the clutch and pick up the load, do so in a smooth manner. Moving the clutch handle too slowly will cause slippage and wear, while moving it too fast will cause quick engagement and possible damage to the power take-off, engine or driven equipment. The normal force required to engage the clutch is 55 lbf (245 N) for the over-centre type and 25 lbf (110 N) for the spring loaded type.

Throttle Control (where fitted)

The throttle control adjusts engine speed. Initial engine speed adjustment is obtained by pressing the throttle control release button while pulling the throttle knob out to increase the engine speed or pushing it in to decrease the engine speed. A final fine speed adjustment is obtained by turning the throttle control counterclockwise to increase engine speed or clockwise to decrease engine speed.

INSTRUMENTS

Your Ford Powered Equipment will have been fitted with instruments selected by the manufacturer. The types of instruments most likely to be encountered are detailed here. A typical instrument panel is shown below.

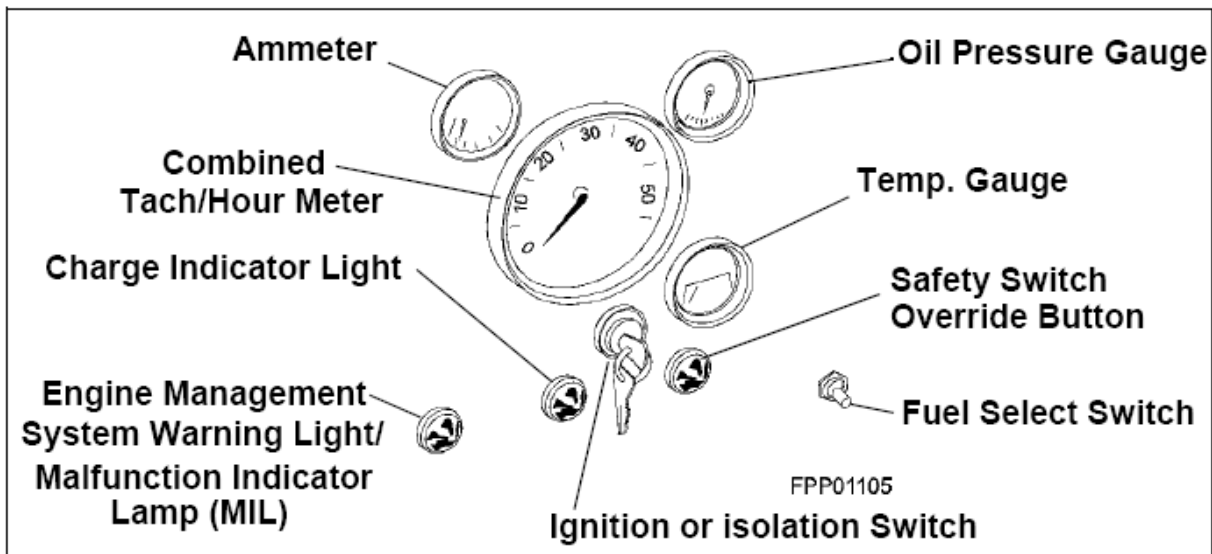

Ammeter (Where Fitted)

This instrument registers the charging current which is being passed to the battery from the alternator. It also registers a discharge equivalent to the amount of current being used by the electrical equipment when the alternator is not charging.

Battery Condition Indicator (Where Fitted)

This is sometimes fitted instead of an ammeter and measures the battery voltage thus indicating the state of charge of the battery.

Tachometer (Where Fitted)

The tachometer indicates the actual engine running speed in crankshaft revolutions per minute.

Hourmeter (Where Fitted)

This instrument records the number of hours of operation which the engine has completed at the rated rpm. It is frequently combined with the tachometer and is used to determine when an engine service operation is required. If no hourmeter is fitted, a log should be kept.

Oil Pressure Gauge (Where Fitted)

The oil pressure gauge registers the lubricating system pressure in bar (kgf/cm² or lbf/in²) and should be frequently observed to ensure that the system is functioning correctly.

Temperature Gauge (Where Fitted)

The temperature gauge enables a close check to be kept on the coolant temperatures.

Malfunction Indicator Light (Where Fitted)

Used on all industrial engines. This light will illuminate whenever there is an engine malfunction such as low oil pressure, high engine temperature, fuel injection system fault. The engine can be programmed to shut down in the event of a malfunction.

Charge Indicator Light (Where Fitted)

If an alternator is fitted to your engine, a charge indicator light will also be fitted. The light will glow when the isolating switch is in the RUN position with the engine stationary and will therefore serve as a reminder either to turn the isolating switch to the OFF position or to start the engine. Once the engine has started, the charge indicator light should cease glowing.

Safety Switch Override Button (Where Fitted)

This must be depressed when starting the engine, as the safety switch operates when the oil pressure falls due to the engine stopping -- Refer to "Safety Switch (where fitted)" on page 14.

Ignition or Isolation Switch

-- Refer to "Ignition or Isolation Switch" on page 13.

Fuel Select Switch (Where Fitted)

This switch is incorporated for use with dual fuels. Switch must point to selection of fuel being used.

STARTING THE ENGINE



WARNING: ALL INTERNAL COMBUSTION ENGINES GIVE OFF VARIOUS FUMES AND GASES WHILE RUNNING. DO NOT START OR RUN THE ENGINE IN A CLOSED OR POORLY VENTILATED BUILDING WHERE THE EXHAUST GASES CAN ACCUMULATE. AVOID BREATHING THESE GASES AS THEY MAY CONTAIN POISONOUS CARBON MONOXIDE WHICH CAN ENDANGER YOUR HEALTH OR LIFE IF INHALED STEADILY FOR EVEN A FEW MINUTES.

Initial Start-up

On initial start-up follow the daily regular maintenance schedule illustration -- Refer to "RECOMMENDED MAINTENANCE SCHEDULES" on page 20.

To Start From cold

1. Where possible, disconnect the driven equipment, eg, fully depress the clutch where a manual transmission is fitted. If your unit is equipped with the engine warning light system, always turn the ignition switch to the ON position to make sure that each warning light is operating before starting engine.
2. Switch on the ignition and operate the starter motor until the engine fires.

NOTE: Where a safety switch is fitted, the override button must be depressed while the engine is being cranked.

3. Set the throttle to give a fast idle speed until normal operating temperature is reached (where fitted).

CAUTION: If the engine stalls or falters in starting, wait 3-4 seconds before re-engaging starter. This will prevent possible damage to the starter or engine. The starter should not operate for periods longer than 30 seconds at a time. An interval of at least two minutes should be observed between such cranking periods to protect the starter from overheating.

To Re-start When Warm

Switch on the ignition and operate the starter motor until the engine starts.

NOTE: Safety shut-down incorporated in the Ignition Performance Module (IPM): Oil pressure below 6 psi and/or coolant temperature goes above 250°F, will shutdown the ignition system.

NOTE: The IPM will also shut the engine off when engine speed reaches 2250 rpm for Gen-Set and 4000 rpm for all other applications. Key must be recycled to restart.

NOTE: Where a safety switch is fitted, the override button must be depressed while the engine is being cranked.

STOPPING THE ENGINE

Normal Conditions

Following normal operating conditions, lower the engine speed to idle, disengage the clutch, and then turn the ignition switch to the OFF position. If the engine has been running under high power, let it run at fast idle speed a few minutes to cool the engine down.

Abnormal Conditions

Under abnormally overheated conditions, the engine may continue to run after the ignition switch is turned off. If this case is ever encountered, turn on the ignition switch immediately and allow the engine to idle until it has cooled enough to stop. If the engine is overheated due to loss of coolant, it is best to stop the engine immediately, if necessary by applying the load. Add engine oil if necessary, then after the engine has returned to a normal temperature, add coolant slowly until the radiator is full.



WARNING: TO REDUCE THE RISK OF INJURY WHEN CHECKING A HOT ENGINE. COVER THE RADIATOR CAP IN A THICK CLOTH AND TURN IT SLOWLY COUNTERCLOCKWISE TO THE FIRST STOP. AFTER THE PRESSURE HAS BEEN COMPLETELY RELEASED, PRESS THE CAP DOWNWARD AND FINISH REMOVING THE CAP.

The above instructions also apply to engines that stop due to operation of the low oil pressure/high water temperature safety switch. However, if the engine stops due to low oil pressure, do not restart until the cause has been determined and corrected -- Refer to "Recommended Lubricants" on page 21.

RUNNING-IN PROCEDURE

A new or reconditioned engine must not be run at high speeds or on full load for the first 25 hours. The load and speed may be increased to a maximum over this period. After the first 50 hours running, carry out the maintenance operations listed

-- Refer to "RECOMMENDED MAINTENANCE SCHEDULES" on page 20.

Check the instruments frequently and keep the coolant and oil filled to their recommended levels.

FUEL RECOMMENDATION

This engine is designed to operate on dry fuel such as LPG Grade HD5 or NG (1050 BTU/ft³).

CAUTION: Use of fuels rated lower than the grades specified above may cause persistent, heavy spark knock, which can lead to engine damage. If your engine knocks heavily, or if you hear continuous spark knock while maintaining constant operating speeds, consult your distributor or another qualified technician.

LUBRICATION AND MAINTENANCE

The importance of correct lubrication, periodic inspection and adjustment cannot be over-emphasized. It will determine, to a very large extent, the service the engine will give. Detailed instructions regarding this maintenance are given in the following pages.

Your Authorized EDI Distributor listed in the back section of this manual, will be pleased to carry out this regular maintenance for you. The various maintenance operations are listed -- Refer to "RECOMMENDED MAINTENANCE SCHEDULES" on page 20.

When carrying out any of the following maintenance operations, any fault or malfunction should be reported immediately to the supervisor or person responsible for engine overhaul or repair.

The following Maintenance Schedules give the maximum recommended service periods. Since operating conditions can vary, it may be advisable to carry out some operations, for example, changing the engine oil, at an interim period. Your operating experience is the best guide for determining this time.

RECOMMENDED MAINTENANCE

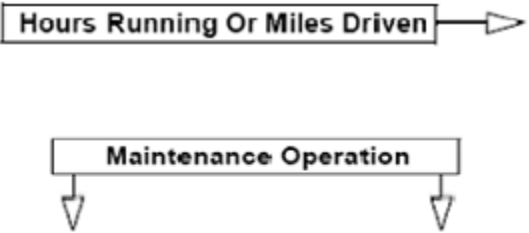
	Daily	After 1st 50 hrs. (2500 km or 1500 miles)	Every 100 hrs. (5000 km or 3000 miles)	Every 200 hrs. (10,000 km or 5000 miles)	Every 400 hrs. (20,000km or 12,000 miles)	Every 800 hrs. (40,000 km or 24,000 miles)	Every 4 years max.
Check engine oil level and top up if necessary	X	X					
Check engine coolant level and top up if necessary with correct mixture	X	X					
Check visually for oil, fuel or coolant leaks	X						
Check all instruments, controls and warning lights. Check hot and cold start functions	X						
Check coolant, oil, fuel, exhaust and vacuum hoses/pipes for leaks, damage, deterioration and correct routing. Check all visible electrical wiring for security, correct routing and evidence of chafing or heat damage.		X	X	X	X	X	
Change engine oil and renew oil filter					X	X	
Check belt condition and replace if necessary				X	X	X	
Check fuel filter element and renew as necessary				X	X	X	
Renew air cleaner element					X	X	
Spark plugs replace every 3,000 hours							
Check all nuts & bolts for tightness					X	X	
Inspect PCV Valve					X	X	
Clean coolant filler cap and renew cap if seal has deteriorated							X
Lubricate PTO bearings if equipped			X	X	X	X	

*It is recommended that this operation is carried out by an authorized Ford Distributor. Depending upon the quality of the fuel used, it may be necessary to renew the filter element more frequently.

** PCV Valve inspection and Spark Plug replacement are recommended at the interval(s) described. Spark plug cleaning/replacement at these intervals will ensure maximum engine performance, fuel economy, and emissions. Failure to complete recommended maintenance does not disqualify your engine from any emissions related warranty coverage's

RECOMMENDED MAINTENANCE OPERATIONS

Recommended Lubricants

CAUTION: Do not use supplemental oil additives or other engine treatments. They are unnecessary and could, under certain conditions, lead to engine damage which is not covered by Ford warranty.

Lubricating oil cleanliness is vital for the successful operation of your engine. The oil should be stored under the cleanest possible conditions. When changing or topping-up engine oil use only clean receptacles. Do not allow the oil to come into contact with rubber hoses on the engine.

Recommended Oil		
Weight/Viscosity	API Spec.	Temperature
5W-30	SP or newer	Above -22F / -30C
0W-30		Below -22F / -30C

CAUTION: Use Ford/Motorcraft “Formula E” SAE 5W-30 engine oil or equivalent that meets Ford Specification WSS-M2C961-A1 (API Classification – SP). Use Ford/Motorcraft “Formula E” SAE 0W-30 engine oil or equivalent that meets Ford Specification WSS-M2C963-A1. Use only engine oil displaying the American Petroleum Institute Certification Mark on the front of the container, or API specification SP

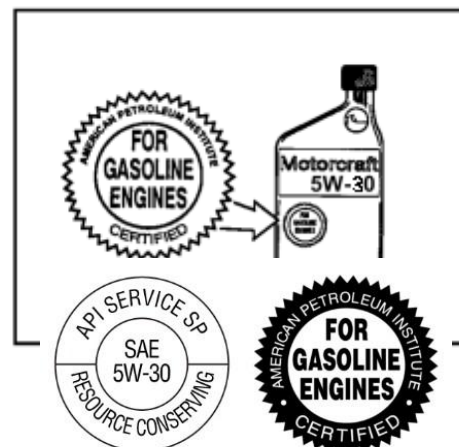

NOTE: EDI industrial engines are designed to perform with engine oils that are licensed by the American Petroleum Institute (API), and oils carrying the most current API classification should be used. API classifications are broken into two categories, gasoline and diesel engines. API’s classification is designated by a two letter system. The first letter, the prefix, designates gasoline or diesel. An “S” designates gasoline and a “C” designates diesel. The second letter in the system designates the level of the classification. It should be noted that alternative fuel engines fall into the “gasoline” API category.

Gasoline engines that are converted for LPG or Natural Gas applications must use oils labeled SP. Do not use oils that are specifically formulated for Diesel Engines only. CC or CD classification, even when labeled Heavy Duty or for Natural Gas Engines, are not acceptable. The use of SAE 5W-30 is recommended for ambient temperatures down to -22F (-30C). The use of SAE 0W-30 is recommended for ambient temperatures below -22F (-30C).

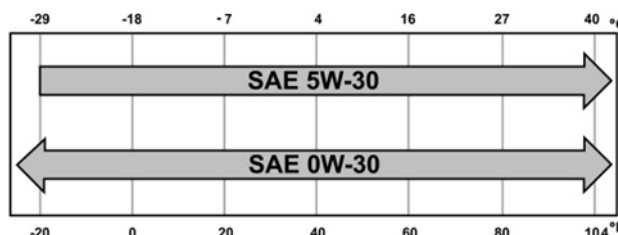

Used Engine Oils



WARNING: PROLONGED AND REPEATED CONTACT MAY CAUSE SERIOUS SKIN DISORDERS INCLUDING DERMATITIS AND SKIN CANCER.

WARNING: AVOID EXCESSIVE CONTACT—WASH THOROUGHLY AFTER CONTACT. KEEP OUT OF THE REACH OF CHILDREN.

WARNING: PROTECT THE ENVIRONMENT: IT IS ILLEGAL TO POLLUTE DRAINS, WATER COURSES OR SOIL. USE AUTHORIZED FACILITIES FOR DISPOSAL. IF IN DOUBT, CONTACT YOUR LOCAL AUTHORITY FOR ADVICE.

WARNING: DO NOT HANDLE A HOT OIL FILTER WITH BARE HANDS. CONTINUOUS CONTACT WITH USED MOTOR OIL HAS CAUSED SKIN CANCER IN LABORATORY MICE. PROTECT YOUR SKIN BY WASHING WITH SOAP AND WATER IMMEDIATELY AFTER CONTACT.

Change Engine Oil

1. Warm the engine to normal operating temperature.
2. Make sure that the equipment is standing level and that the engine is stopped.
3. Obtain a sufficiently large draining pan to accommodate the engine oil -- Refer to "Service Oil fill capacity (including filter):" on page 38.
4. Remove the oil filler cap from the rocker cover, remove the drain plug from the oil pan and drain the oil into the draining pan.

NOTE: Modern high performance oils have a cleaning action on the engine which may turn the oil dark, but does not necessarily indicate inadequate oil changes.

5. Replace and tighten the drain plug, then fill the engine via the filler neck in the rocker cover with the correct quantity of oil -- Refer to "SPECIFICATIONS" on page 38.
6. Replace the oil filler cap and run the engine for no more than 30 seconds.
7. Check the oil level as described in the following section.

Check Engine Oil Level

1. Make sure the equipment is standing level and that the engine is stopped.
2. Pull out the dipstick and wipe it with a clean rag.
3. Insert the dipstick fully and again remove it. At no time should the level of the oil fall below the lower mark on the dipstick.
4. If necessary, top up to the dipstick higher mark with an approved type and grade of oil.
5. Replace the dipstick, ensuring that it is fully inserted into its tube to maintain a sealed crankcase condition

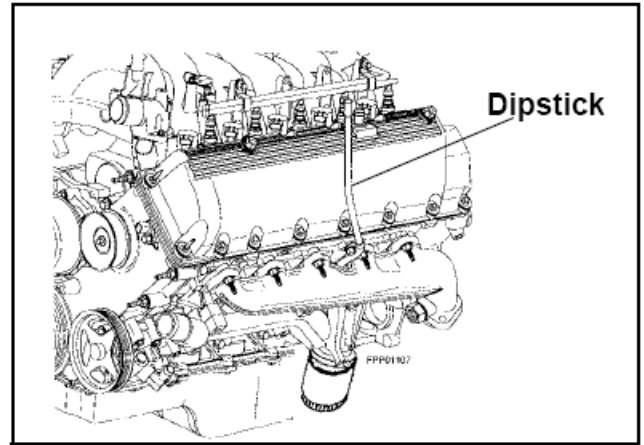

Renew Engine Oil Filter

CAUTION: The original oil filter is not available for service. Use the recommended Motorcraft FL-820S.

Your engine is equipped with a Motorcraft oil filter. A filter of this quality should be used throughout the life of the engine. It is designed to protect your engine by filtering harmful abrasive and sludgy particles without clogging up or blocking the flow of the oil to vital engine parts. This filter is especially designed for use in engines built by Ford to give successful operation with the recommended oil filter change intervals. Contact your nearest EDI Distributor/Dealer listed in the back section to obtain the correct filter. Before commencing, place a drain pan beneath the filter to catch any spilt oil.



1. Using a suitable strap wrench, unscrew the oil filter canister.
2. Thoroughly clean oil filter housing face.
3. Partly pre-fill the new filter with clean engine oil of the correct type and grade. Apply a thin film of clean engine oil to the oil filter sealing ring.
4. Screw on new oil filter canister until sealing ring abuts the filter head and tighten a further 1/2 turn. Do NOT use a strap wrench or similar tool to tighten the filter canister.
5. Run engine and check for any leaks from oil filter.
6. Stop engine, allow oil to settle and top up as necessary.

Ignition System

The 6.2L engine is equipped with a coil-on-plug ignition system. Rather than a remotely mounted coil with secondary ignition wires, this system has a separate ignition coil mounted on each spark plug. Operation of the coils is controlled by the engine computer module (GCP), which computes ignition timing based on inputs from engine sensors.

Renew Spark Plugs



WARNING: THE IGNITION SYSTEM COMMONLY CARRIES VOLTAGES IN EXCESS OF 30,000 VOLTS. PLEASE USE CAUTION.

CAUTION: Do not pull directly on the lead as this could cause the wire connection inside the boot to become separated.

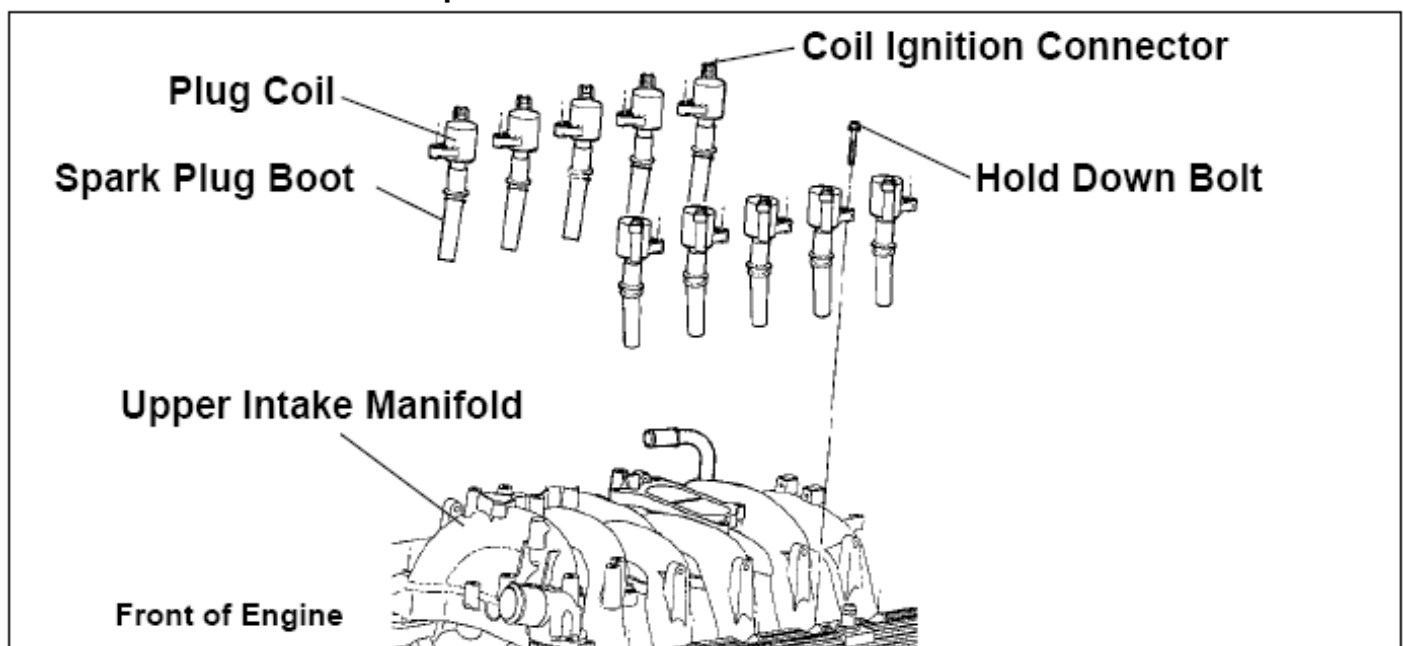

NOTE: To remove spark plugs you must first remove coils.

1. Disconnect the ignition coil wire connectors.
2. Remove the hold down screw then the coil.

NOTE: For fuel rail clearance rotate coils 45° clockwise and lift out.

3. After loosening each spark plug one or two turns with a proper spark plug spanner, clean the area around each spark plug port with compressed air then remove the spark plugs.



WARNING: PROTECTIVE GOGGLES MUST BE WORN TO PROTECT THE EYES WHEN USING COMPRESSED AIR.

4. Check the gaps of the new spark plugs with a feeler gauge, and, where necessary, bend the outer ground extension to achieve the specified gap.

5. Use a proper spark plug spanner to avoid damaging the insulators, screw the new spark plugs into the cylinder head and tighten them to the specified torque value listed under specification of this manual.

NOTE: Do not over tighten spark plugs as the gap may change considerably due to the distortion of the plug outer shell.

6. Coat the inside of each spark plug boot with silicone dielectric compound D7AZ-1 9A33 1-A (USA) or equivalent, using a small nscrewdriver blade.

7. Install the plug coils and tighten hold down bolt to 5-7 Nm (44-62 in-lb).

NOTE: Coils are interchangeable.

8. Reconnect ignition coil wire connectors.

Firing Order 1-3-7-2-6-5-4-8

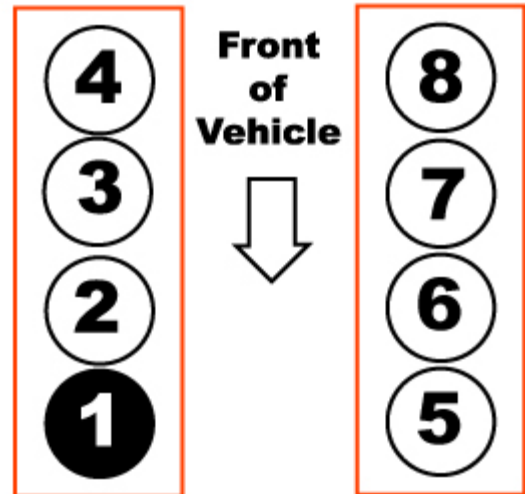

Electronic Actuator

In the event that your engine is equipped with an electronic actuator, any necessary adjustment should be made by your Power Products Distributor listed at the back of this manual. The adjusting procedure requires the use of tools which are not readily available to consumers

Check Condition of Ancillary Drive Belts



WARNING: ENGINE SHOULD BE STOPPED AND ANY REMOTE STARTER DISABLED BEFORE CHECKING BELTS.

The serpentine ancillary belt used to drive the generator and water pump, is tensioned automatically and does not require adjustment.

The belts should be visually inspected for signs of wear or damage. It should be renewed if necessary. Refer to Service Manual.

NOTE: May be purchased from your local Ford Power Product Distributor listed on the back of this handbook.

Check Engine Coolant Level



WARNING: TO REDUCE THE RISK OF INJURY WHEN CHECKING A HOT ENGINE. COVER THE RADIATOR CAP WITH A THICK CLOTH AND TURN IT SLOWLY COUNTER-CLOCKWISE TO THE FIRST STOP. AFTER THE PRESSURE HAS BEEN COMPLETELY RELEASED, PRESS DOWNWARD AND FINISH REMOVING CAP. FAILURE TO FOLLOW THESE INSTRUCTIONS COULD RESULT IN DAMAGE TO THE COOLING SYSTEM OR ENGINE AND/OR PERSONAL INJURY.

CAUTION: Do not add coolant to an engine that has become overheated until the engine cools. Adding coolant to an extremely hot engine can result in a cracked block or cylinder head.

1. Allow the engine to cool down to 40°C (110°F).
2. Turn the radiator expansion/degas tank filler cap through 90° in a counterclockwise direction. Pause to allow any pressure to drop, then turn cap fully counterclockwise and remove it.
3. The quantity of coolant in the expansion/degas tank is a direct indication of the coolant level in the complete system. The acceptable level of coolant in the expansion/degas tank is shown by the level indicators moulded into the tank wall. Top up as necessary with a mixture of plain water and antifreeze -- Refer to "Cooling System" on page 28 for information on mixing antifreeze solutions.

NOTE: It is essential that only the correct type of antifreeze is used -- Refer to "Cooling System" on page 28.

4. Replace the filter cap and turn down tightly.

Renew Air Cleaner Element

Your air cleaner filters air entering the engine induction system and acts as a silencer and a flame arrester. Air that contains dirt and grit produces an abrasive fuel mixture, and can cause severe damage to the cylinder walls and piston rings. Damage to the cylinder walls and piston rings will cause high oil consumption and short engine life. A restricted or dirty air cleaner will also cause a rich fuel mixture. Thus, it is extremely important that the air cleaner be serviced at recommended intervals.

CAUTION: Service the air cleaner more frequently under severe dust conditions to prevent engine damage.

1. Release the air cleaner lid retaining hardware.
2. Lift the air cleaner lid clear of the air cleaner body, then remove the air cleaner element and discard it.
3. Wipe the inside of the air cleaner body and lid clean, using a lint-free rag.
4. Insert the new element, ensuring that it fits properly and install air cleaner lid.

Renew PCV Valve

1. Detach the hose, from the top of the PCV valve located at the top rear of right valve cover and from the intake manifold.
2. Withdraw the PCV valve from the valve cover grommet.
3. Discard the PCV valve and the 'O' ring.
4. Thoroughly clean the inside and outside of the hose.
5. Insert the new PCV valve, complete with a new 'O' ring.
6. Re-connect the hose to the PCV valve and to the intake manifold.

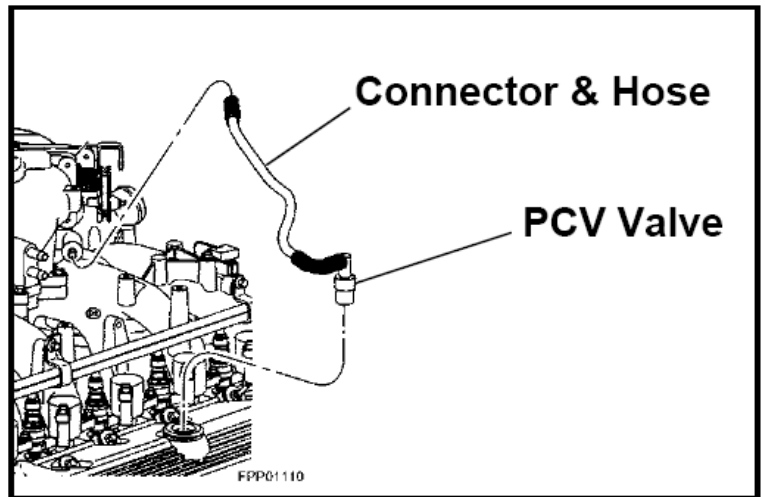

GENERAL MAINTENANCE INFORMATION

The following section outlines some aspects of general maintenance which will be of value to the operator.

Cooling System

To obtain maximum engine service life, its operating temperature must be maintained by an efficient cooling system.

CAUTION: Under no circumstances should the engine be started without liquid in the cooling system. This may cause permanent damage to the engine.

Inspect the exterior of the radiator for obstructions, remove all bugs, dirt or foreign material with a soft brush or cloth.

Use care to avoid damaging the fins. If available, use low pressure compressed air or a stream of water in the opposite direction to normal airflow. Check all hoses and connections for leaks. If any of the hoses are cracked, frayed, or feel spongy, they should be replaced.

CAUTION: Never use a cold coolant mixture to top-up the radiator or degas tank of a hot engine if the coolant level is very low; this could cause serious engine damage.

The radiator or degas tank is equipped with a pressure cap. It is dangerous to remove this when the system is very hot.



WARNING: NEVER REMOVE THE PRESSURE RELIEF CAP WHILE THE ENGINE IS OPERATING OR WHEN THE COOLING SYSTEM IS HOT. MAY CAUSE PERSONAL INJURY OR DAMAGE TO COOLING SYSTEM OR ENGINE. TO REDUCE THE RISK OF HAVING SCALDING HOT COOLANT OR STEAM BLOW OUT OF THE DEGAS BOTTLE WHEN REMOVING THE PRESSURE RELIEF CAP, WAIT UNTIL THE ENGINE HAS COOLED DOWN TO AT LEAST 40°C (110°F).

1. Wrap a thick cloth around the pressure relief cap and turn it slowly one-half turn counterclockwise. Stepping back while the pressure is released from the cooling system.
2. When you are sure all the pressure has been released, (still with a cloth) turn counterclockwise and remove the pressure relief cap.

In territories where freezing conditions may occur, the coolant should consist of a mixture of 50% plain water and 50% Motorcraft Super Plus 2000 coolant. This antifreeze contains additional corrosion inhibitors designed to provide lasting protection for the engine.

Only this antifreeze, or proprietary antifreeze meeting Ford specification WSSM97B44-D or Ford specification ESE-M97B44-A should be used when topping-up or re-filling the cooling system.

Motorcraft Super Plus 2000 coolant has long life characteristics and if the concentration is kept to a maximum of 50% it will provide adequate frost protection and inhibiting for the life of the engine.

NOTE: If a major component of the cooling system is renewed such as the radiator, water pump etc., the system should be flushed and re-filled with a 50% solution of Motorcraft Super Plus 2000 coolant and clean water.

In territories where the ambient temperature is such that no protection against freezing is required, it is recommended that a 25% concentration of Motorcraft Super Plus 2000 coolant is used. This will protect water pumps, core plugs, thermostat housings and radiators against corrosion for the life of the engine and raise boiling point when used at this concentration. See previous Note on renewing cooling system components.

The antifreeze concentration in a cooling system can be determined by using a suitable hydrometer.

- A reading of 1080 represents a 50% antifreeze concentration.
- A reading of 1040 represents a 25% antifreeze concentration.
- A reading of 1000 represents plain water.



WARNING: ANTIFREEZE CONTAINS MONO ETHYLENE GLYCOL AND OTHER CONSTITUENTS WHICH ARE TOXIC IF TAKEN INTERNALLY AND CAN BE ABSORBED IN TOXIC AMOUNTS ON REPEATED OR PROLONGED SKIN CONTACT. PERSONS USING ANTIFREEZE ARE RECOMMENDED TO ADHERE TO THE FOLLOWING PRECAUTIONS:

- **ANTIFREEZE MUST NEVER BE TAKEN INTERNALLY. IF ANTIFREEZE IS SWALLOWED ACCIDENTALLY, MEDICAL ADVICE SHOULD BE SOUGHT IMMEDIATELY.**
- **PRECAUTIONS SHOULD BE TAKEN TO AVOID SKIN CONTACT WITH ANTIFREEZE. IN THE EVENT OF ACCIDENTAL SPILLAGE ONTO THE SKIN, ANTIFREEZE SHOULD BE WASHED OFF AS SOON AS PRACTICABLE. IF CLOTHING IS SPLASHED WITH ANTIFREEZE, IT SHOULD BE REMOVED AND WASHED BEFORE BEING WORN AGAIN, TO AVOID PROLONGED SKIN CONTACT.**
- **FOR REGULAR AND FREQUENT HANDLING OF ANTIFREEZE, PROTECTIVE CLOTHING (PLASTIC OR RUBBER GLOVES, BOOTS AND IMPERVIOUS OVERALLS OR APRONS) MUST BE USED TO MINIMIZE SKIN CONTACT.**

Draining, Flushing and Filling the Cooling System



WARNING: NEVER REMOVE THE PRESSURE RELIEF CAP WHILE THE ENGINE IS OPERATING OR WHEN THE COOLING SYSTEM IS HOT. MAY CAUSE PERSONAL INJURY OR DAMAGE TO COOLING SYSTEM OR ENGINE. TO REDUCE THE RISK OF HAVING SCALDING HOT COOLANT OR STEAM BLOW OUT OF THE DEGAS BOTTLE WHEN REMOVING THE PRESSURE RELIEF CAP, WAIT UNTIL THE ENGINE HAS COOLED DOWN TO AT LEAST 40°C (110°F).

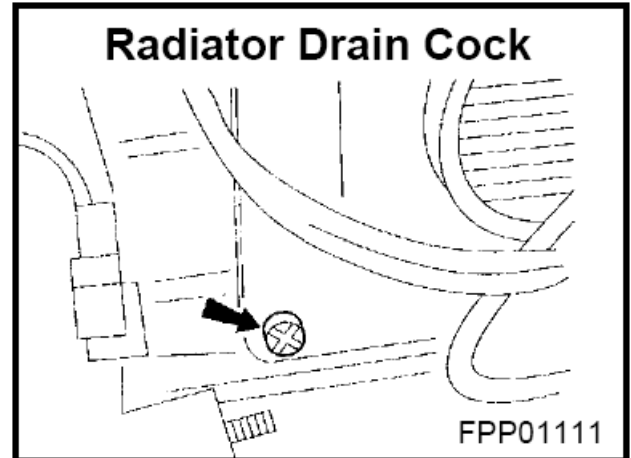

1. Wrap a thick cloth around the pressure relief cap and turn it slowly one-half turn counterclockwise. Stepping back while the pressure is released from the cooling system.
2. When you are sure all the pressure has been released, (still with a cloth) turn counterclockwise and remove the pressure relief cap.
3. Remove the radiator expansion/ degas tank filler cap, then open the radiator drain cock, where fitted, or detach the bottom radiator hose.
4. Flush the system with water using a hose until clean water emerges and allow all water to drain out. Close the drain cock (or replace the bottom radiator hose). Recover all old antifreeze and dispose of properly. Contact your local municipal government for the proper disposal.
5. Fill the system with the correct coolant mixture via the expansion/degas tank filler neck. Fill the system slowly, to avoid air locks, up to the 'maximum' mark on the degas tank.
6. Run engine and check hose connections for leaks. Check, and, if necessary, top up the coolant in the radiator or degas tank.

Engine Lubrication System

The lubrication system should be maintained regularly -- Refer to "RECOMMENDED MAINTENANCE SCHEDULES" on page 20, with the correct grade of lubricant as specified in the maintenance summary -- Refer to "Recommended Lubricants" on page 21. The system is of the force feed type, the lubricating oil being circulated to the engine bearings under pressure by an oil pump driven from the camshaft drive chain belt.

The dipstick provides some guide to the condition of the oil. An additive type of oil keeps soot in suspension, and even a small amount of soot causes the oil to darken rapidly.

However, if the dipstick is found to be heavily coated with sludge, then obviously the oil should be changed.

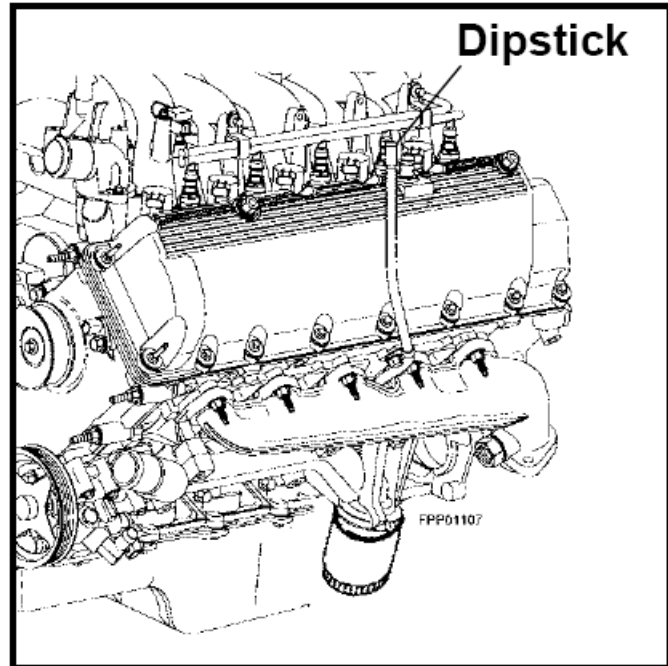

Electrical System

A NEGATIVE EARTH (NEGATIVE GROUND) SYSTEM IS USED.

ECU - Power Distribution Box

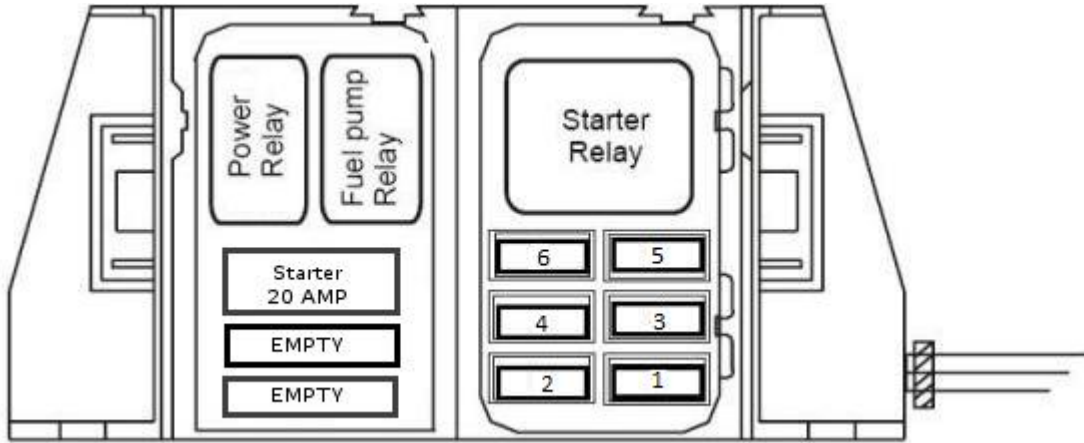

Fuse	Amps	Circuits protected
1	10	Battery Voltage to EPR
2	5	Ignition Voltage to GCP and Relays
3	10	Battery Voltage to GCP
4	15	Fuel pump
5	15	Battery Voltage out of Power Relay
6	10	Alternator

Generator

This is mounted on a bracket at the front of the engine and is driven from the crankshaft by a serpentine belt.

The charging rate is adjusted automatically by the built-in regulator to provide sufficient electric current to keep the battery fully charged under normal operating conditions.

The generator requires no lubrication or maintenance.



WARNING: IT IS ESSENTIAL THAT THE WIRING CONNECTIONS TO THE GENERATOR ARE NOT REMOVED WHILE THE ENGINE IS RUNNING, AS THIS WILL RESULT IN DAMAGE TO THE REGULATOR OR PERSONAL INJURY.

Storage

Storage - One Month

- While the engine is running, treat upper cylinders by spraying engine fogging agent (from your local aftermarket supplier) into the air intake for about two minutes. Open throttle for short burst of speed, shut off engine and allow it to come to a stop while continuing to spray into air intake.
- Leave spark plugs in holes or seal spark plug holes with suitable threaded metal plugs and cover all openings into engine with dust-proof caps or shields (suitable non-hygroscopic material).
- If engine is less transmission, spray flywheel and ring gear with mixture of one part recommended engine oil, and one part Stoddard Solvent or equivalent.
- Check coolant protection. Store indoors in dry area.

Storage - Indefinite Period

- Drain crankcase completely and refill with recommended engine oil, (SAE 10) or equivalent.
- Run engine and treat upper cylinders by spraying fogging agent into the air intake for about two minutes. Open throttle for short burst of speed, shut off engine and allow it to come to a stop while continuing to spray into air intake.
- Check coolant protection
- Disconnect and remove battery.
- Clean exterior surface of engine.
- Leave spark plugs in holes or seal spark plug holes with suitable threaded metal plugs.
- Seal all openings in engine and accessories with non-hygroscopic material. Mask off all areas to be used for electrical contacts.
- Make sure all surfaces are dry, then spray all taped openings, all engine accessories including ignition wiring, and all exterior surfaces of engine with Insulation Compound.
- If engines are equipped with automotive type clutch, block clutch in slightly disengaged position so that lining and pressure plates are not in contact.

ENGINE SYSTEM CHECK

GCP System Check

NOTE: Most items listed in the possible cause column may not set a diagnostic fault indicator or illuminate the MIL light.

NOTE: EDI engines are used in many different applications and equipment. When performing any system diagnosis be aware of any OEM inputs or equipment monitoring devices that may have an effect on the engine's performance or any of the engine's operating systems.

Engine Performance - No Load

SYMPTOM	POSSIBLE CAUSE
Engine Runs Briefly and Shuts Down	<ul style="list-style-type: none">• Loss of Spark• Frozen Fuel Regulator (Dry Fuel)• Low Fuel Pressure• Air Inlet Restriction• Wiring Failure• IPM Failure
Engine Cranks But No Start	<ul style="list-style-type: none">• Coil Power Loss• IPM Ground Loss• IPM Power Loss• Severe Vacuum Leak (Dry Fuel)• Air Inlet Restriction• Air Inlet Leak (Dry Fuel)• Fuel Lock-Off Inoperative (Dry Fuel)• Wiring Failure• Low Fuel Pressure• Ancillary Components Binding
Engine Runs Poorly	<ul style="list-style-type: none">• High Fuel Pressure• Low Fuel Pressure• Contaminated Fuel• Incorrect Fuel Select Table Selected• Wrong IPM Installed• Actuator Air Blockage• TMAP Sensor Leak• Fuel Contaminated• Noise Suppression Capacitor Failure• Improper PCV Routing• Valve Timing• Low Cylinder Compression
Engine Cranks Slowly	<ul style="list-style-type: none">• Excessive Engine Load (Hydraulic Pump Failing, Binding Ancillary Drive Components)• Low Battery Voltage• Incorrect Battery Specifications• Incorrect Battery Cable Size• Starter Relay• Starter Failure (Excessive Drain)

SYMPTOM	POSSIBLE CAUSE
Engine Does Not Crank	<ul style="list-style-type: none">• Dead Battery• Ground Loss• Coil Power Loss• Ancillary Components Binding or Seized• OEM Shutdown - Oil Level Safety• Starter Lockout Relay Failure• Ignition Switch Failure• Bad Starter• Crank Control Wire Failure• Loose Connection or Corrosion

Engine Performance - While Under Load

SYMPTOM	POSSIBLE CAUSE
Engine Stalls/Quits	<ul style="list-style-type: none"> • Faulty OEM Drivers Safety Shut-off Seat Switch • Low Battery Voltage • Low Fuel Pressure • OEM Safety Shutdowns • Bad TMAP Sensor • Air Restriction • Coil Failure • Fuel Mixer Binding (Dry Fuel)
Runs Rough	<ul style="list-style-type: none"> • Ground Loss • Misrouted Spark Plug Wires • Fuel System Failure • Vacuum Leak • Wiring Failure • Coil Power Loss • Low Fuel Pressure • Spark Plugs Fouled • Incorrect Valve Timing
Misses	<ul style="list-style-type: none"> • Fuel System Failure • Misrouted Spark Plug Wires • Spark Plug Gap Too High • Spark Plugs Fouled • Cracked Spark Plug Insulator • Coil Power Loss • Incorrect Valve Timing • Compression Loss
Hesitation/Stumble	<ul style="list-style-type: none"> • Low Fuel Pressure • Spark Plugs Fouled • TMAP Sensor Vacuum Signal Loss
Surge	<ul style="list-style-type: none"> • Low Fuel Pressure • TMAP Sensor Failure • Application or Ancillary System Momentarily Binding During Load or Unload

SYMPTOM	POSSIBLE CAUSE
Backfires	<ul style="list-style-type: none"> • Faulty OEM Drivers Safety Shut-off Seat Switch • Fouled Spark Plugs • Spark Plug Wire Broke • IPM Momentary Ground Loss • Excess Lean Condition • Coil Failure • Fuel Lock-Off Leaking (Dry Fuel) • Intake Manifold Leak • Bad Intake Valve
Lack of Power	<ul style="list-style-type: none"> • Ancillary Components Binding • Intake Air Restriction • Crossed Spark Plug Wires • Spark Plugs Fouled • Fuel System Failure • Low Fuel Pressure • Low Cylinder Compression
Spark Knock	<ul style="list-style-type: none"> • Poor Quality or Contaminated Fuel • Carbon Build-up • Wrong Spark Plugs (Too High Heat Range) • Fuel Delivery System • PCV System • Fuel Selection Timing • Cylinder Hot Spots

Engine Concerns

SYMPTOM	POSSIBLE CAUSE
Oil System Concerns - High Oil Consumption	<ul style="list-style-type: none"> • Positive Crankcase Ventilation (PCV) System • Oil Viscosity • External Leaks • Improper Oil Dipstick • Valve Seals • Cylinder Wall Taper Excessive • Worn Piston Rings
Cooling System Concerns	<ul style="list-style-type: none"> • Trapped Air • Worn Drive Belt • Worn Water Pump • Stuck Thermostat • Plugged Radiator (Internal & External) • Dry Fuel System Running Rich
Exhaust System Concerns (visible smoke) - Black Smoke - Blue Smoke	<ul style="list-style-type: none"> • Ignition System • Fuel Delivery System • Sticking Fuel Injector • High Fuel Pressure • PCV System • Worn Piston Rings • Worn Valve Guides

SYMPTOM	POSSIBLE CAUSE
Fuel System Concerns	<ul style="list-style-type: none"> • Leaky Lines • Contaminated Fuel • Excessive Alcohol in Fuel • Incorrect Octane Rating
Engine Noise	<ul style="list-style-type: none"> • Low Oil Pressure • Oil Filter Restriction

SPECIFICATIONS

GENERAL SPECIFICATIONS	
Engine Type:	V-8, 16 valves, 4 Stroke spark ignition 90° Overhead Valve (OHV) chain driven camshaft operating the valves via roller cam followers and hydraulic lash adjusters.
Liter/CID:	6.2L / 379 CID
Bore: mm (inch)	102 (4.02)
Stroke: mm (inch)	95 (3.74)
Number of Cylinders:	8
Compression Ratio:	9.8:1

FUEL SYSTEM	
LPG Fuel Specification:	Liquefied Petroleum Gas Fumigation EN589 (European) HD-5 USA
NG Fuel Specification:	Natural Gas Fumigation 1050 btu/ft ³ / 38.7 MJ/m ³ (UK) 11" H ₂ O into DEPR
Gasoline Fuel Specification:	Gasoline (petrol) Unleaded 87 or 89 Octane (Gasoline blends not to exceed 10% Ethanol by volume Octane Index of 87 or 89).
Gasoline Fuel Pump Pressure:	45 psia (~30psig at the rail)

LUBRICATION SYSTEM	
Max. Oil Pressure:	Hot @ 2500RPM: 275.79 - 413.69 kPa (40-60psi)
Oil Type:	GF-6A, SAE 5W-30 (down to -22F/-30C) GF-6A, SAE 0W-30 (below -22F/-30C)
Service Oil Fill Capacity (including filter):	7 quarts (6.6L)
Oil Filter:	Ford Service Part #: F1AZ-6731-AD Motorcraft: FL820-S

COOLING SYSTEM	
Thermostat:	Type: Wax Element Starting Opening: 192°F (88.9°C) Fully Open: 212°F (100°C)
Coolant:	50% Motorcraft Super Plus 2000 plus 50% clear water Ford Specification: WSS-M97B44-D or ESE-M97B44-A

DRIVE BELT	
Belt Length and Type:	6 Groove Serpentine Belt 82.5 inches (2095.5mm)

ELECTRICAL SYSTEM	
Polarity:	Negative to earth (ground)
Grounding:	Ground B- directly to Engine Block. Engine Block ground strap to chassis (unpainted surface)
Alternator Output:	157 Amp @ 2,000 RPM
Minimum Battery Capacity:	750 CCA / 140 RC (950 CCA @ 0°F)

IGNITION SYSTEM	
Spark Plug:	Ford Service Part #: AL3E-12405-BA Motorcraft: CYFS-12-FP Gap: 1.12mm (0.044in.)
Firing Order:	1 – 5 – 4 – 8 – 6 – 3 – 7 – 2

TIGHTENING TORQUES

ITEM	Nm	FT. LB.	LB. IN.
Oil Pan Drain Plug	20-34	15-25	98-143
Spark Plugs	8-12	7-15	71-106
Oil Filter	14-17	11-12	
Coil Hold Down bolts	5-7		44-62

CONVERSION TABLE

TO CONVERT FROM TO	TO FROM	MULTIPLY BY DIVIDE BY
Distance		
inches	mm	25.4
inches	m	0.0254
feet	mm	304.8
feet	m	0.3048
yards	m	0.9144
mile	km	1.609
Area		
in ²	mm ²	645.16
ft. ²	m ²	0.0929
yds ²	m ²	0.8361
Volume		
in ³	cm ³	16.3871
in ³	1 liter	0.016387
pint (us)	1 liter	0.47318
pint (uk)	1 liter	0.56826
quart (us)	1 liter	0.94635
gallon (us)	1 liter	3.7854
gallon (uk)	1 liter	4.5461
ft. ³	1 liter	28.3168
ft. ³	m ³	0.02832
Mass		
oz.	g	28.3495
lb.	kg	0.45359
ton (US)	tonne	0.90718
ton (UK)	tonne	1.01605
FORCE		
lbf	N	4.44822
PRESSURE & STRESS		
kpa	Bar	0.01
lbf/in ² (psi)	N/m ²	6894.76
lbf/in ² (psi)	Bar	0.0689
lbf/in ² (psi)	N/mm ²	0.00689
lbf/m ² (psi)	mmHg	51.715
"H ₂ O	mmH ₂ O	25.4
"Hg	mmHG	25.4
ton (US)/in ²	N/mm ²	13.7894
ton (UK)/in ²	N/mm ²	15.4443
VELOCITY		
ft./sec.	m/s	0.3048
ft./sec.	km/h	1.09728
miles/h	m/s	0.44694
miles/h	km/h	1.609
ACCELERATION		
ft./sec ²	m/s ²	0.3048
ENERGY		
Btu	J	1055.06
Kcal	J	4186.8
HP.h	kW.h	0.7457
PS.h	kW.h	0.7355
TORQUE		
lb./ft.	Nm	1.35582
POWER		
HP	kW	0.7457
PS	kW	0.7355
HP	PS	1.01387
SPECIFIC FUEL CONSUMPTION		
lb./hp.h	g/kW.h	608.277

EDI DISTRIBUTORS

Visit www.edi-dist.com/distributors for a complete list of North American and Worldwide distributors.

or Call 1-800-220-2700



Engine Distributors, Inc.

400 University Court

Blackwood, NJ 08012

1-856-228-7298

1-800-220-2700

1-856-228-5657(fax parts)

1-856-228-5531(fax sales)